

D F X - 8 0 0 0

**SERVICE MANUAL**

**EPSON**

## NOTICE

- ' All rights reserved. Reproduction of any part of this manual in any form whatsoever without SEIKO EPSON's express written permission is forbidden.
- \* The contents of this manual are subject to change without notice.
- " All efforts have been made to ensure the accuracy of the contents of this manual. However, should any errors be detected, SEIKO EPSON would greatly appreciate being informed of them.
- \* The above notwithstanding SEIKO EPSON can assume no responsibility for any errors in this manual or the consequences thereof.

Copyright 1990 by SEIKO EPSON CORPORATION  
Nagano, Japan

## PRECAUTIONS

Precautionary notations throughout the text are categorized relative to 1 ) personal injury, and 2) damage to equipment:

**DANGER** Signals a precaution which, if ignored, could result in serious or fatal personal injury. Great caution should be exercised in performing procedures preceded by a DANGER headings.

**WARNING** Signals a precaution which, if ignored, could result in damage to equipment.

The precautionary measures itemized below should always be observed when performing repair/maintenance procedures.

### DANGER

1. ALWAYS DISCONNECT THE PRODUCT FROM BOTH THE POWER SOURCE AND THE HOST COMPUTER BEFORE PERFORMING ANY MAINTENANCE OR REPAIR PROCEDURE.
2. NO WORK SHOULD BE PERFORMED ON THE UNIT BY PERSONS UNFAMILIAR WITH BASIC SAFETY MEASURES AS DICTATED FOR ALL ELECTRONICS TECHNICIANS IN THEIR LINE OF WORK.
3. WHEN PERFORMING TESTING AS DICTATED WITHIN THIS MANUAL, DO NOT CONNECT THE UNIT TO A POWER SOURCE UNTIL INSTRUCTED TO DO SO. WHEN THE POWER SUPPLY CABLE MUST BE CONNECTED, USE EXTREME CAUTION IN WORKING ON POWER SUPPLY AND OTHER ELECTRONIC COMPONENTS.

### WARNING

1. REPAIRS ON EPSON PRODUCT SHOULD BE PERFORMED ONLY BY AN EPSON CERTIFIED REPAIR TECHNICIAN.
2. MAKE CERTAIN THAT THE SOURCE VOLTAGE IS THE SAME AS THE RATED VOLTAGE, LISTED ON THE SERIAL NUMBER/RATING PLATE. IF THE EPSON PRODUCT HAS A PRIMARY-AC RATING DIFFERENT FROM THE AVAILABLE POWER SOURCE, DO NOT CONNECT IT TO THE POWER SOURCE.
3. ALWAYS VERIFY THAT THE EPSON PRODUCT HAS BEEN DISCONNECTED FROM THE POWER SOURCE BEFORE REMOVING OR REPLACING PRINTED CIRCUIT BOARDS AND/OR INDIVIDUAL CHIPS.
4. IN ORDER TO PROTECT SENSITIVE  $\mu$ P CHIPS AND CIRCUITRY, USE STATIC DISCHARGE EQUIPMENT, SUCH AS ANTI-STATIC WRIST STRAPS, WHEN ACCESSING INTERNAL COMPONENTS.
5. REPLACE MALFUNCTIONING COMPONENTS ONLY WITH THOSE COMPONENTS RECOMMENDED BY THE MANUFACTURER; INTRODUCTION OF SECOND-SOURCE ICS OR OTHER NONAPPROVED COMPONENTS MAY DAMAGE THE PRODUCT AND VOID ANY APPLICABLE EPSON WARRANTY.

# PREFACE

This manual describes functions, theory of electrical and mechanical operations, maintenance, and repair of the DFX-8000.

The instructions and procedures included herein are intended for the experienced repair technician, and attention should be given to the precautions on the preceding page. The chapters are organized as follows:

**Chapter 1 - Provides a general product overview, lists specifications, and illustrates the main components of the printer.**

**Chapter 2 - Describes the theory of printer operation.**

**Chapter 3 - Includes a step-by-step guide for product adjustment.**

**Chapter 4 - Includes a step-by-step guide for product disassembly and assembly.**

**Chapter 5 - Provides Epson-approved techniques for troubleshooting.**

**Chapter 6 - Describes preventive maintenance techniques and lists lubricants and adhesives required to service the equipment.**

**.The contents of this manual are subject to change without notice.**

# TABLE OF CONTENTS

<b>CHAPTER 1.</b>	<b>GENERAL SPECIFICATIONS</b>
<b>CHAPTER 2.</b>	<b>OPERATING PRINCIPLES</b>
<b>CHAPTER 3.</b>	<b>DISASSEMBLY AND ASSEMBLY</b>
<b>CHAPTER 4.</b>	<b>ADJUSTMENT</b>
<b>CHAPTER 5.</b>	<b>TROUBLESHOOTING</b>
<b>CHAPTER 6.</b>	<b>MAINTENANCE</b>
<b>APPENDIX</b>	

REV.-A

### REVISION TABLE

REVISION	DATE ISSUED	CHANGE DOCUMENT
A	July 2, 1990	1st issue

# CHAPTER 1

## GENERAL SPECIFICATIONS

1.1	<b>FEATURES</b> .....	1-1
1.2	<b>SPECIFICATIONS</b> .....	1-2
1.2.1	General Specifications.....	1-2
1.2.1.1	Printing .....	1-2
1.2.1.2	General Paper Specifications .....	1-4
1.2.1.3	Single Part Form .....	1-8
1.2.1.4	Multi-part Forms .....	1-9
1.2.1.5	Label Form .....	1-11
1.2.1.6	Overlapping Multi-part Forms .....	1-13
1.2.1.7	Ribbon Specification .....	1-14
1.2.1.8	Electrical Specifications .....	1-14
1.2.1.9	Environmental .....	1-14
1.2.1.10	Physical .....	1-15
1.2.1.11	Reliability .....	1-15
1.2.1.12	Safety Approvals .....	1-15
1.2.2	Interface Specifications .....	1-16
1.2.2.1	parallel Interface .....	1-16
1.2.2.2	Serial Interface.....	1-19
1.3	<b>OPERATOR CONTROL</b> .....	1-21
1.3.1	Control Panel .....	1-21
1.3.2	Self-test Function.....	1-24
1.3.3	Hexadecimal Dump Function.....	1-25
1.3.4	DIP Switch Jumper Setup.....	1-26
1.3.5	Buffer Full Printing .....	1-29
1.3.6	Buzzer .....	1-29
1.3.7	Error Detection Function .....	1-29
1.3.8	Paper End Detection Function.....	1-30
1.3.9	Cover Open Detection Function .....	1-30
1.3.10	Automatic Paper Thickness Detection .....	1-31
1.3.11	Automatic Paper Width Detection .....	1-31
1.3.12	Non-volatile User-defined Characters .....	1-31
1.3.13	Paper Memory Function .....	1-32
1.3.13.1	Using the Paper Memory Feature .....	1-33
1.3.13.2	Saving Paper Format and Thickness Information .....	1-33

1.3.13.3 Loading Paper Format Information from Memory .....	1-37
1.3.14 Paper Cutter .....	1-37
1.3.15 Copy Mode .....	1-38
1.3.16 Printer initialization .....	1-38
1.4 MAJOR Units.....	1-39
1.4.1 Printer Mechanism Model.3C65 .....	1-39
1.4.2 Power Supply Board Unit .....	1-41
1.4.3 Main Board .....	1-42
1.4.4 Driver Board .....	1-43
1.4.5 Control Panel .....	1-44
1.4.6 Housing .....	44

## LIST OF FIGURES

Figure 1-1. DFX-8000 .....	1-1
Figure 1-2. Printhead Pin Configuration .....	1-2
Figure 1-3. Unsuitable Paper .....	1-5
Figure 1-4. Forms Over Ride Area .....	1-5
Figure 1-5. Pitch or Perforation .....	1-6
Figure 1-6. Side Edge of Perforation .....	1-6
Figure 1-7. perforation Intersection .....	1-6
Figure 1-8. Raised Part at Perforation .....	1-7
Figure 1-9. Sprocket Hole -1 .....	1-7
Figure 1-10. Bad Folded Paper.....	1-7
Figure 1:1 1. Printable Area of Single Part Form .....	1-8
Figure 1-12. Dotted Paste Positions .....	1-9
Figure 1-13. Stapling Part -1 .....	1-10
Figure 1-14. Stapling Part -2 .....	1-10
Figure 1-15. Stapling Part -3.....	1-10
Figure 1-16. Sprocket Hole -2 .....	1-10
Figure 1-17. Label Form Printable Area -1 .....	1-f f
Figure 1-18. Label Form Printable Area -2 .....	1-11
Figure 1-19. Label and Carrier .....	1-12
Figure 1-20. Printable Area of Over-lapping Multi-part Forms .....	1-13
Figure 1-21. Multi-part Paper Binding Method .....	1-13
Figure 1-22. Hand Shake Timing .....	1-16



Figure 1-23.	36-pin 57.3 <b>0360</b> Connector	1-16
Figure 1-24.	<b>DTR</b> Control Handshake Timing	1-19
Figure 1-25.	<b>XON/OFF</b> Control Handshake Timing	1-20
Figure 1-26.	EIA Standard 25 Pin Assignment	<b>1-20</b>
Figure 1-27.	Control Panel	1-21
Figure 1-28.	Self-test Print <b>out</b>	1-24
Figure 1-29.	Hexadecimal Dump List	1-25
Figure 1-30.	Multi-part Forms with Labels	1-32
Figure 1-31.	Overlapping Multi-part Forms	1-32
Figure 1-32.	Horizontal Align-Top Edge	1-35
Figure 1-33.	Vertical Align-Left Corner	1-35
Figure 1-34.	Horizontal Align-Bottom	1-35
Figure 1-35.	Vertical Align-Right Corner	1-36
Figure 1-36.	Model-3C65 Printer Mechanism	1-39
Figure 1-37.	BOPS Board	1-41
Figure 1-38.	BOPSE Board	1-41
Figure 1-39.	<b>C030MAIN</b> Board	1-42
Figure 1-40.	C030DRV Board	1-43
Figure 1-41.	Control Panel	1-44
Figure 1-42.	Housing	1-44

## LIST OF TABLES

Table 1-1.	Options and Expendable	1-1
Table 1-2.	Character Size, Pitch	1-3
Table 1-3.	Printing Column Width	1-3
Table 1-4.	Printing Speed	1-4
Table 1-5.	Each Part Weight of the Multi-part Form	1-9
Table 1-6.	Parallel Interface Pin Assignment	1-17
Table 1-7.	<b>DC1/DC3</b> Control	1-18
Table 1-8.	<b>DTR</b> and <b>XON/XOFF</b> Control	1-19
Table 1-9.	Serial Interface Pin Assignment	1-20
Table 1-10.	DIP Switch Selections	1-26
Table 1-11.	Character Set Selection	1-28
Table 1-12.	interface Setup	1-28
Table 1-13.	Baud Rate	1-28
Table 1-14.	Jumper Setup	1-28
Table 1-15.	Paper Memory Select	1-33

**REV.-A**

Table 1-16. Page Length Set .....	1-33
Table 1-17. DIP SW 3-5 and 3-6 .....	<b>1-34</b>
Table 1-18. DIP SW 3-5 and 3-6 .....	<b>1-34</b>
Table 1-19. DIP SW 3-5 and 3-6 .....	<b>1-37</b>
Table 1-20. Major Components of Model-3 <b>C65</b> .....	1-40
Table 1-21. Major Components of the BOPS/BOPSE Board .....	1-41
Table 1-22. Major Components of the <b>C030MAIN</b> Board .....	1-42
Table 1-23. Major Components of the C030DRV Board .....	1-43

# 1.1 FEATURES

The DFX-8000 is a 18 pin serial dot matrix printer with a maximum speed of 1060cPs. This system was designed for full-fledged business use, and places emphasis on high-speed printing, heavy duty specifications and continuous sheet handling. The main features of this system are as follows:

- **Maximum printing speed:**
  - 1060 cps (High-speed draft mode)
  - 960 cps (Draft elite mode)
  - 800 cps (Draft pica mode)
- **Bi-directional two way push tractor**
- **Most advanced paper handling**
  - Automatic tractor select function
  - Automatic paper back-out and loading function
  - Automatic paper thickness measurement
  - Automatic platen(-head) gap adjustment
  - Automatic paper width detection
  - Paper statement memory backup function
  - Copy mode can be selected by control panel
- **Optional paper cutter**
- **Standard 8 bit parallel interface and RS-232C standard serial interface**
- **EPSON ESC/P-83 printer driver (Compatible with FX-850/1050, DFX-5000)**
- **IBM Pro-printer emulation mode**
- **3k byte input data buffer**
- **Compatible with EPSON optional interface board series #81 XX**

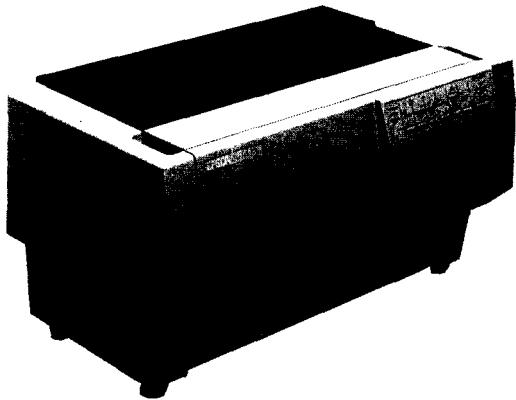

Figure 1-1. DFX-8000

Table 1-1. Options and Expendable

Group	No./Code	Name /Description
Option	#8309 #C8 15001 #C8 15002 #8 XXX	<b>Pull tractor unit</b> <b>Paper cutter unit (for EAI version)</b> <b>Paper cutter unit (for another version)</b> <b>Optional interface board series</b>
Expendable	#8766 #8767	<b>Ribbon cartridge</b> <b>Ribbon pack</b>

## 1.2 SPECIFICATIONS

This chapter describes the specifications of the DFX-8000.

### 1.2.1 General Specifications

This section describes general specifications with the exception of the interface specifications.

#### 1.2.1.1 Printing

Printing method:

**Serial impact dot matrix**

Pin configuration:

**18 wires (a double column of 9 wires, see Figure 1-2)**

Pin diameter:

**0.29 mm**

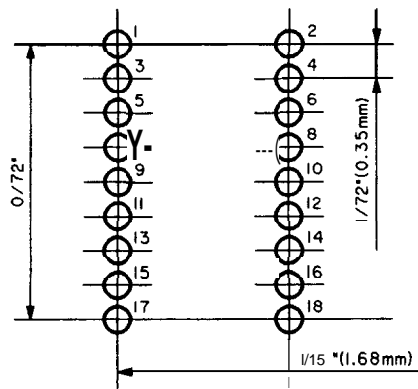

Figure 1-2. Printhead Pin Configuration

**Dot matrix:**

9 X 9 (Draft)  
18 X 20 (NLQ)  
9 X 7 (High speed Draft)

**Printing direction:**

**Text mode**

**Bi-directional with logic seeking**  
(Uni-directional print can be specified by program)

**Bit image mode**

**Uni-directional**

**Built in character sets:**

**ASCII characters**  
**International characters (13 countries)**

**Graphics**

**Built in fonts:**

**Draft**  
**NLQ Roman**  
**NLQ Saris-serif**

**Printing pitch:**

**2.54 mm (10 CPI)**  
**0.423 mm (60 DPI)**

**Paper feeding:** **Bi-directional variable width push tractor feed**

**NOTE:** Push or pull feed is also available, using the optional pull tractor unit.

(See Chapter 3 for details.)

**Line spacing:** **1/6" or 1/8" (DIP switch setting/programmable)**  
**n/2 16" (programmable)**

**Paper feed speed:**

**Line feed(1/6° feed) 26 ms (6"/sec)**

**Form feed(continuous) 17 ms (10"/sec)**

**Character size: See Table 1-2**

**Character pitch: See Table 1-2**

Table 1-2. Character Size, Pitch

Printing mode	Width [mm]	Height [mm]	Total character width [mm]	Pitch [CPI]
<b>Pica (Normal)</b>	<b>2.1</b>	<b>3.1</b>	<b>2.54</b>	<b>10</b>
<b>Emphasized pica</b>	<b>2.1</b>	<b>3.1</b>	<b>2.54</b>	<b>10</b>
<b>Condensed pica</b>	<b>1.05</b>	<b>3.1</b>	<b>1.48</b>	<b>17</b>
<b>Elite</b>	<b>1.7</b>	<b>3.1</b>	<b>2.11</b>	<b>12</b>
<b>Condensed elite</b>	<b>0.85</b>	<b>3.1</b>	<b>1.27</b>	<b>20</b>

NOTES: 1. The total character width is the total of character width and the character spacing (in dots).

2. In the proportional mode, total character width varies because of different character spacings.

**Printing column width:**

**See Table 1-3**

Table 1-3. Printing Column Width

Printing mode	Printable column width [CPL] (max.)
<b>Pica mode</b>	<b>136</b>
<b>Condensed pica mode</b>	<b>233</b>
<b>Elite mode</b>	<b>163</b>
<b>Condensed elite mode</b>	<b>272</b>

NOTE: **CPL...Character Per Line**

REV.-A

Printing speed:

See Table 1-4  
Table 1-4. Printing Speed

Printing mode	Printing speed[CPS]
High speed draft (pica)	1066
Draft (pica)	800
Draft (elite)	960
Condensed draft (pica)	680
Emphasized draft (pica)	400
NLQ (pica)	160
NLQ (elite)	192

Input data buffer size:

3 K bytes

### 1.2.1.2 General Paper Specifications

Feeding method:

Tractor feed

Type:

Continuous (Fan-fold) paper

- Single-part form
- Multi-part forms
- Label form
- Overlapping multi-part forms

Quality:

High quality paper

Width:

101 – 406.4 mm (4 – 16 inches)

Length:

Min. 88.9 mm (3.5 inches, label form)

Width:

4 – 16 inches (101 – 406 [mm])

Total thickness:

Front tractor

Within 0.46 mm

Within 0.018 inches

Rear tractor

Within 0.30 mm

Within 0.012 inches

NOTES: 1. Horizontal alignment may be irregular in the top 75 mm (3inches) of the first page.

2. When using the optional pull tractor unit, do not print on the top 120mm (4.8 inches) of the first page.

3. Clean paper (with no folds, creases, or tears, (especially for the copying paper)) should be used. Figure 1-3 shows paper that is unsuitable.

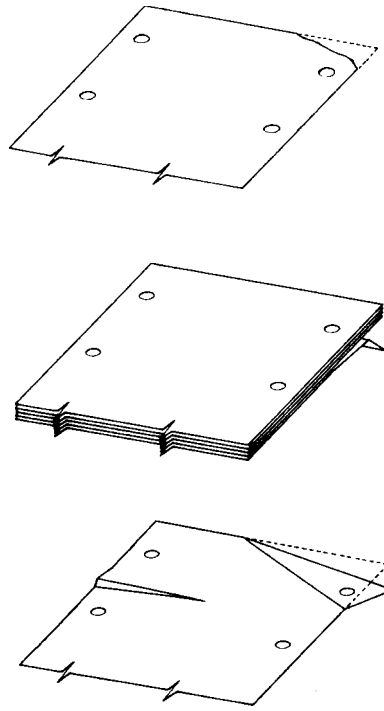

Figure 1-3. Unsuitable Paper

4. Forms-override printing is available 20 lines after paper end. The paper feeding pitch is not guaranteed. The end of printable area is 15mm from the bottom edge of paper.

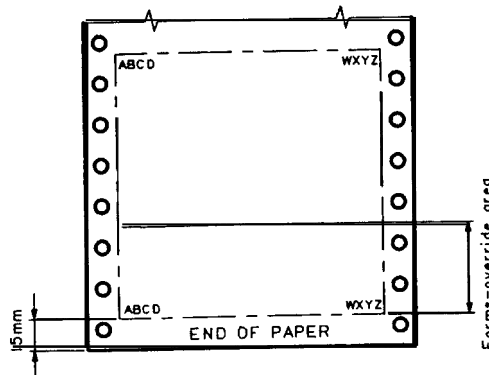

Figure 1-4. Forms Over Ride Area

3. Clean paper (with no folds, creases, or tears, (especially for the copying paper)) should be used. Figure 1-3 shows paper that is unsuitable.

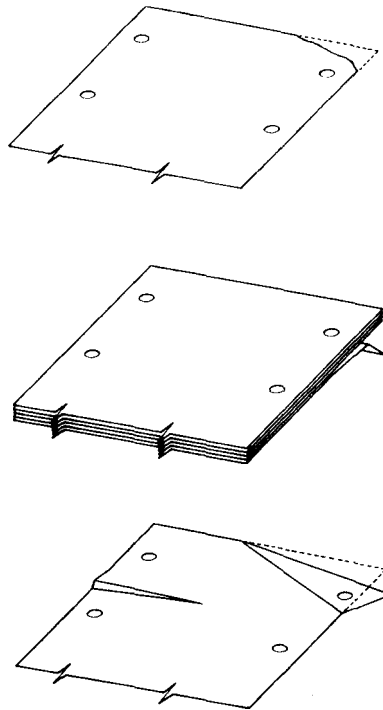

Figure 1-3. Unsuitable Paper

4. Forms-override printing is available 20 lines after paper end. The paper feeding pitch is not guaranteed. The end of printable area is 15mm from the bottom edge of paper.

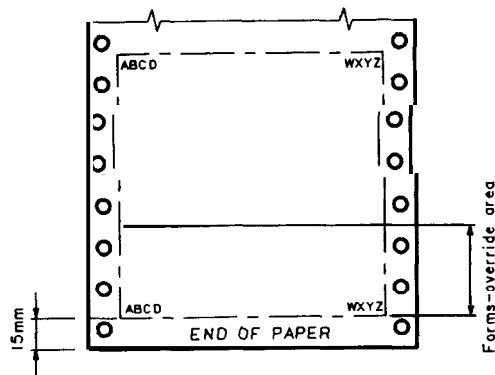

Figure 1-4. Forms Over Ride Area



REV.-A

5. Weak horizontal and vertical perforations cause paper jams.
6. The pitch of perforations (pitch of the cut part and uncut part) must be less than 3: 1 (ratio).

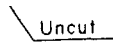

Figure 1-5. Pitch of Perforation

7. Perforations must have an uncut part on each side edge of the paper.

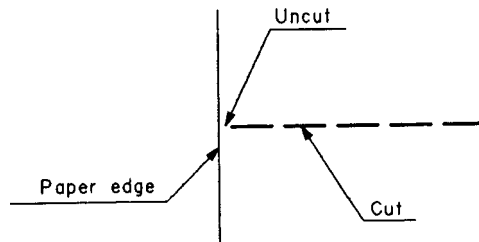

Figure 1-6. Side Edge of Perforation

8. At the intersection of horizontal and vertical perforations, the cut part of the Perforations must not cross each other. Figure 1-7 shows examples of good perforation intersections.

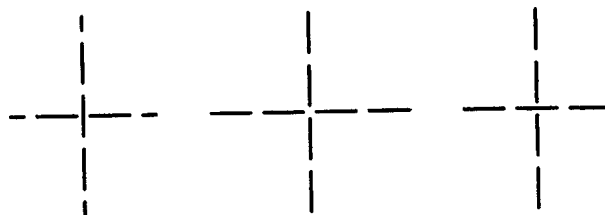

Figure 1-7. Perforation Intersection

- 9 The raised portion at a perforation (fold) must be less than 1 mm from the flat part, with the bottom layer kept flat by force.

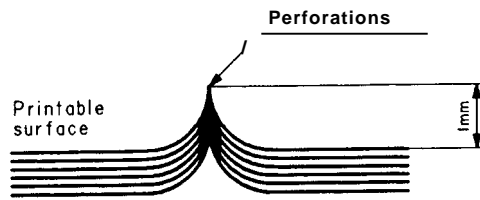

Figure 1-8. Raised Portion at a Perforation

10. The sprocket hole must be circular. The hole may have teeth.

11. The

12. The

that is not folded properly, as shown below.



Figure 1-10. Bad Folded Paper

13. No holes are acceptable in the printable area.
14. The paper must be torn off accurately along a perforation.

REV.-A

1.2.1.3 Single Part Form

weight:

Weight of paper is indicated in [Kg], [lb.], and [g/m<sup>2</sup>].

45 – 70 Kg

14 – 22 lb.

52.6 – 82.7 g/m<sup>2</sup>

printable area:

See Figure 1-1 I

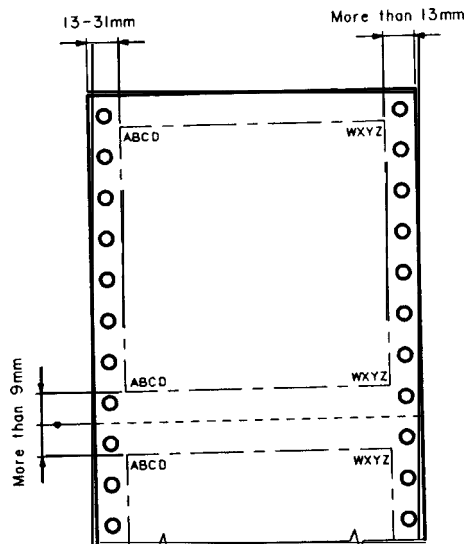

Figure 1-11. Printable Area of Single Part Form

1.2.1.4 Multi-part Forms

Printable area: Same with "Single part form" (See Figure 1-3)  
 Copying paper:  
     Front tractor Max. 6 sheets (1 original + 5 copies)  
     Rear tractor Max. 4 sheets (1 original + 3 copies)  
 Weight: Weight of paper is indicated in [Kg], [lb.], and [g/m2].  
             35 - 48 Kg  
             11 - 15 lb.  
             41.4 - 56.4 g/m2

Table 1-5. Each Part Weight of a Multi-part Form

Total number of copies	Each part weight [Kg] (except the bottom)	Bottom sheet weight [Kg]
1	45, 55 or 70	45, 55 or 70
2	34 or 45	55 or 70
3	34 or 45	55 or 70
4	34	45, 55 or 70
5	34	45, 55 or 70
6	34	45, 55 or 70

- NOTES: 1. N = 6 (front) or 4 (rear). The total paper thickness of multi-part forms should be less than the maximum allowable paper thickness.  
 2. Carbon-less duplicating paper should be used for copying.  
 3. The copying paper should be joined using dotted paste (Spot-gluing) or 2 points paper staples (Tape-stitching).  
     Dotted paste is recommended for better printing quality.  
 4. If the dotted paste is used, the paper can be joined either on a single side or on both sides.  
     Figure 1-12 shows the specified paste positions.

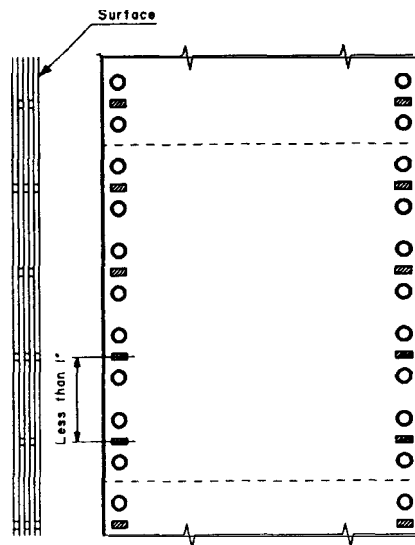

Figure 1-12. Dotted Paste Positions

- 5. The pasted parts must be pressed flat. There must be no creases in the paper.
- 6. Paper-stapling must be applied from the front. Paper must be flat. Figure 1-13 shows the stapling part cross section.

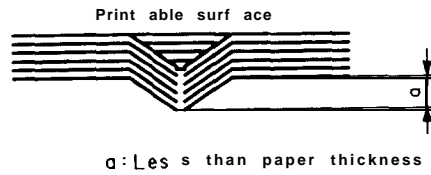

Figure 1-13. Stapling Part -1

- 7. Multi-part forms are fixed firmly to each other. Figure 1-14 shows the stapling part cross section.

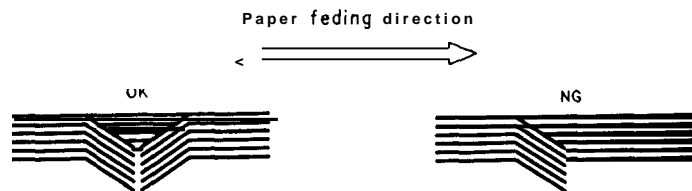

Figure 1-14. Stapling Part -2

- 8. The binding area should be flat. Figure 1-15 shows the stapling part cross section.

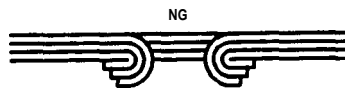

Figure 1-15. Stapling Part -3

- 9. Never use metal staples.
- 10. The position of staple or paste part must be outside of the printable area.
- 11. The sprocket hole of each layer must not be shifted.

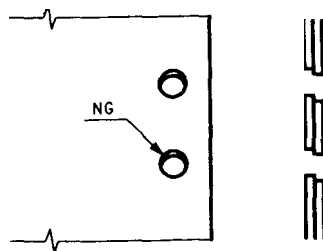

Figure 1-16. Sprocket Hole -2

1.2.1.5 Label Form

Printable area: See Figure 1-17 and 18

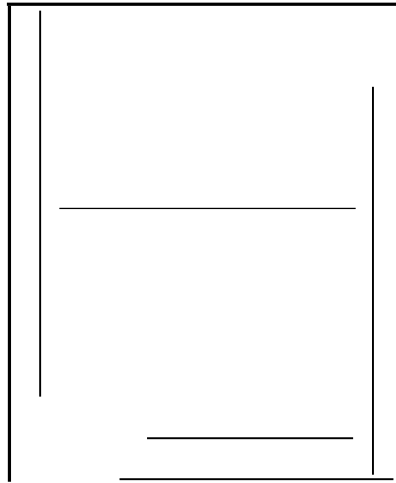

Figure 1-17. Label Form Printable Area -1

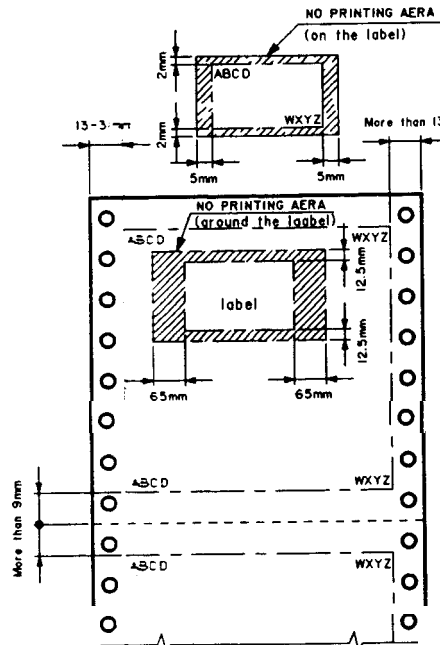

Figure 1-18. Label Form Printable Area -2

WARNING

- Do not perform the back feed.
- Do not perform the paper select.

- NOTES:
1. If label forms are used, the paper should be loaded from the front tractor. The paper select function must not be used.
  2. If label forms are used, the paper should be fed only in the normal direction, using the MICRO FEED switch.
  3. If label forms are used, the paper must not be fed in the reverse direction. (Reverse paper feeding could cause the paper to jam, or the labels to stick to the unit.)
  4. When label forms are used, they must not be torn off.
  5. When label forms are used, the TOF (TOP OF FORM) function should not be executed.
  6. Easy come-off labels should not be used.
  7. Every label must be put on the carrier.

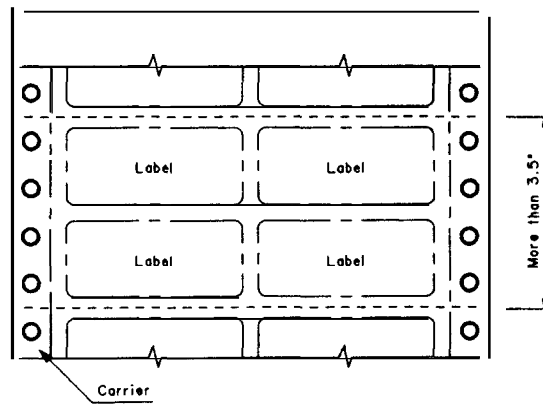

Figure 1-19. Label and Carrier

8. Corners of the labels must be rounded.
9. The surface of label must be flat.

1.2.1.6 Overlapping Multi-part Forms

Printable area:

See Figure 1-20

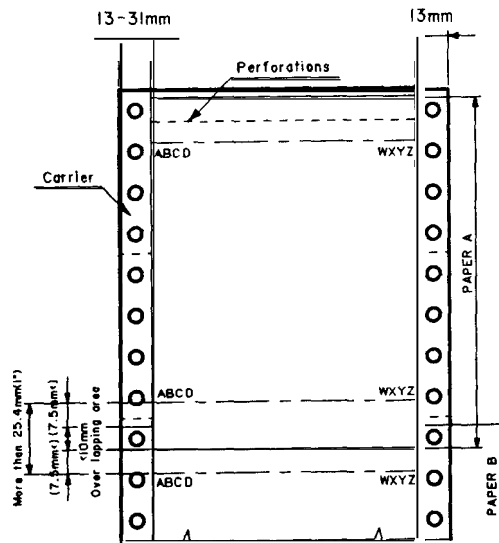

Figure 1-20. Printable Area of Multi-part Forms with Label

**WARNING**

- Do not perform the back feed.
- Do not perform the paper select.

NOTES: 1. The thickness of overlapping area is less than 0.7 mm (0.028 inches).

2. The multi-part paper must be bonded at the top side of multi-part paper. Figure 1-21 shows the multi-part paper binding method.

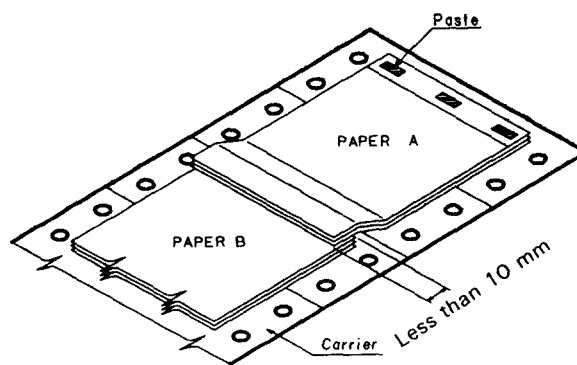

Figure 1-21. Multi-part Paper Binding Method



REV.-A

### 1.2.1.7 Ribbon Specification

**Ribbon cartridge:** # 8 7 6 6  
**Ribbon pack:** # 8 7 6 7  
(The ribbon pack is a handy pack containing an exchangeable endless ribbon.)  
**Ribbon pack exchanges:** Maximum 4 times for one cartridge.  
**Color:** Black  
**Dimension:**  
    **Cartridge** 506(W) X 23(H) X 140(D) mm  
    **Ribbon** 13mm X 70m (Endless)  
**Life:** Approx. 15 million characters (14 dots/chr.)

### 1.2.1.8 Electrical Specifications

**Supply voltage:**  
    **120VAC model** 103.5 to 132 VAC  
    **220-240VAC model** 198 to 264 VAC  
**Rated current:**  
    **120VAC model** 7A  
    **220-240VAC model** 5A  
**Frequency range:** 49.5 to 60.5 Hz  
**Power consumption:** 200W (Self test printing in draft mode)  
**Insulating resistance:** 10 M ohms min. (between the AC line and chassis)  
**Dielectric strength:**  
    **120VAC model** 1000VAC(rms) 1 minute or 1200VAC(rms) 1 second  
    **220-240VAC model** 1250VAC(rms) 1 minute or 1500VAC(rms) 1 second

### 1.2.1.9 Environmental

**Temperature:**  
    **Operating** 5°C to 35°C  
    **Storage** -30°C to 60°C  
**Humidity:**  
    **Operating** 10% to 80% RH. (Non condensation)  
    **Storage** 5% to 85% RH (Non condensation)  
**Impact proof:**  
    **Operating** 1 G (1 msec. or less)  
    **Storage** 2G (1 msec. or less)  
**Vibration proof:**  
    **Operating** Max. 0.25G, 55 Hz  
    **Storage** Max. 0.5G, 55Hz

**1.2.1.10 Physical**

**Dimensions:** 700(W) X 369(H) X 382(D) mm  
(See Figure in APPENDIX)

**Weight:**

Without options 29Kg  
With the pull tractor 30Kg  
With the paper cutter 34Kg

**1.2.1.11 Reliability**

**MCBF:** 24 million lines (except the printhead life)

**MTBF:** 6000 POH (power on hour)

**Life of printhead:** 400 million characters (14 dots/chr.)

**1.2.1.12 Safety Approvals**

**Safety standard:** UL478 5th  
CSA 22.2 # 154  
BSI  
TUV VDE0806  
IEC950

**R.F.1:** FCC class B  
VDE 0871

1.2.2 Interface Specifications

The DFX-8000 employs an 8-bit standard parallel interface, and an RS-232C serial interface.

1.2.2.1 Parallel Interface

Type:	8-bit standard parallel interface
Data format:	8-bit parallel
Logic level:	TTL compatible
Synchronization:	By STROBE pulse
Hand shaking:	By both ACKNLG and BUSY, or either of them
Hand shake timing:	See Figure 1-22
Connector:	57-30360 (AM PHENOLL) or equivalent (See Figure 1-23)

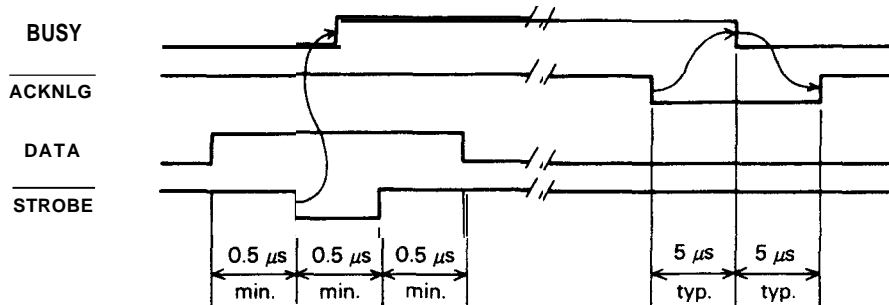

Figure 1-22. Hand Shake Timing

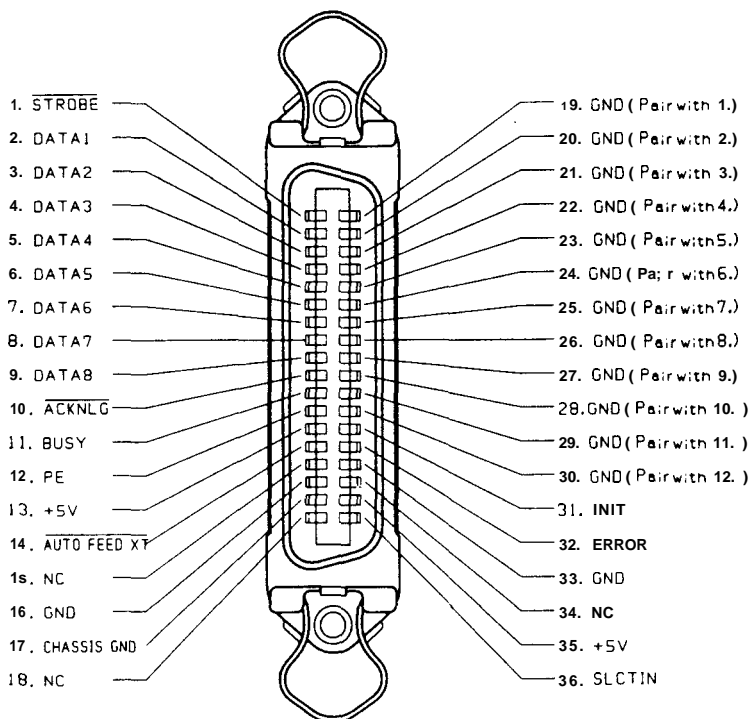

Figure 1-23. 36-pin 57-30360 Connector

Table 1-6. Parallel Interface Pin Assignment

Pin No.	Signal Name	Return Pin No.	DIR	Functional Description
1	$\overline{\text{STROBE}}$	19	In	Strobe pulse to read the input data. Pulse width must be more than 0.5 $\mu\text{s}$ Input data is latched after falling edge of this signal.
2	DATA 1	20	In	Parallel input data to the printer. "HIGH" level means data "1". "LOW" level means data "0".
3	DATA2	21	In	
4	DATA3	22	In	
5	DATA4	23	In	
6	DATA5	24	In	
7	DATA6	25	In	
8	DATA7	26	In	
9	DATA8	27	In	
10	$\overline{\text{ACKNLG}}$	28	out	This pulse indicates data are received and the printer is ready to accept next data. pulse width is approx. 12 $\mu\text{s}$ .
11	BUSY	29	out	HIGH indicates printer can not accept next data.
12	PE	30	out	HIGH indicates papepr-out. This signal is effective only when $\overline{\text{ERROR}}$ signal is "LOW".
13	SLCT	—	out	Always "HIGH" output. (Pulled up to $\div 5\text{V}$ through 3.3K ohms register.)
14	$\overline{\text{AUTO FEED-XT}}$	—	In	If the signal is "LOW" when the printer is initialized line feed is automaitcally performed by input of "CR" code. (Auto LF)
15	—	—	—	Not used
16	GND	—	—	Ground for twisted-pair grounding.
17	Chassis GND	—	—	Chassis ground level of printer
18	—	—	—	Not used.
9 to 30	GND	—	—	Ground for twisted-pair grounding.
31	INIT	16	In	Pulse (width: 50 $\mu\text{s}$ min., active "LOW") input for printer initialization.
32	$\overline{\text{ERROR}}$	—	out	LOW indicates that some error has occurred in the printer.
33	GND	—	—	Ground for twisted-pair grounding
34	—	—	—	Not used.
35	—	—	out	Always "HIGH". (Pulled up to +5V through a 3.3 K-ohm register.)
36	$\overline{\text{SLCT-IN}}$	—	In	If the signal is "LOW" when printer is initialized, the DC 1 /DC3 control is disabled.

REV.-A

- NOTES:
1. "DIR" indicates the input/output direction from the printer side.
  2. The return side means the twisted pair return, which is connected to the signal ground. The interface signals must be sent through twisted pair lines, and the return lines must be connected. The cable should be shielded and the printer chassis ground should be connected to the chassis to reduce noise.
  3. TTL levels must be used for the interface. The rise or fall times of the signals should be 0.2 us or less.
  4. Refer to Figure 1-6. for the signal timing chart.
  5. Data should only be sent according to the ACKNLG and BUSY signals. (Data should be sent to this printer after confirming the ACKNLG signal or when the BUSY signal is low.)
  6. If the proper character codes are sent over the DATA 1 to 8 lines of the interface connector (open should be " 1", and short to GND "0") and the ACKNLG pin is connected to the STROBE pin, the test printing (including the interface circuit) can be performed without any external equipment.
  7. A short in terface cable is recommended to reduce noise.
  8. See Table 1-7. for DC1/DC3 control.

Table 1-7. DC1/DC3 Control

SLCT IN signal state (Initial state)	Code	Printer state	Printer data entry
High	DC 1	Selectable	Enable
	DC3	Not selectable	DC 1 code waiting state. All data before the DC 1 code will be ignored.
Low	DC 1	Usually selected	Usually enabled
	DC3		

1.2.2.2 Serial Interface

Type: RS-232C compatible serial interface  
 Data format: RS-232C compatible serial  
 Word length:  
     Start bit 1  
     Data bit 7 or 8 (Selectable by DIP switch)  
     Parity bit Odd, Even or Non-parity (Selectable by DIP switch)  
     Stop bit 1 bit or more  
 Bit rate: 300, 1200, 9600, 19200 BPS (Selectable by DIP switch)  
 Logic level:  
     MARK (Logical "1") -3V to -27V  
     SPACE (Logical "0") +3V to +27V  
 Synchronization: Asynchronous  
 Hand shaking: By DTR(REV) signal or X-ON/X-OFF protocol

Table 1-8. DTR and XON/XOFF Control

DTR signals	Control code	Printer state and operation
MARK	XOFF (DC3/13H)	Data reception disabled. If the printer is in the(DC3/13H) following states, an XOFF code (DC3/ 13H) is sent to the host computer to set the DTR signal to the MARK level. ● When the available (empty) space in the input data buffer becomes 512 bytes (Buffer full): ● Error state (Off-line, ERROR, or Paper End)
SPACE	XON (DC1/11 H)	Data reception enabled. If the printer is in the (DC 1/1 1 H) following state, an XON code (DC 1 /1 1 H) is sent to the host computer to set the DTR signal to the SPACE level. ● When the empty space in the input data buffer becomes 784 bytes: ● Restored from ERROR state (ON-LINE)

Handshake timing: See Figure 1-24. and Figure 1-25.  
 Connector: EIA Standard 25 pin connector (See Figure 1-26.)

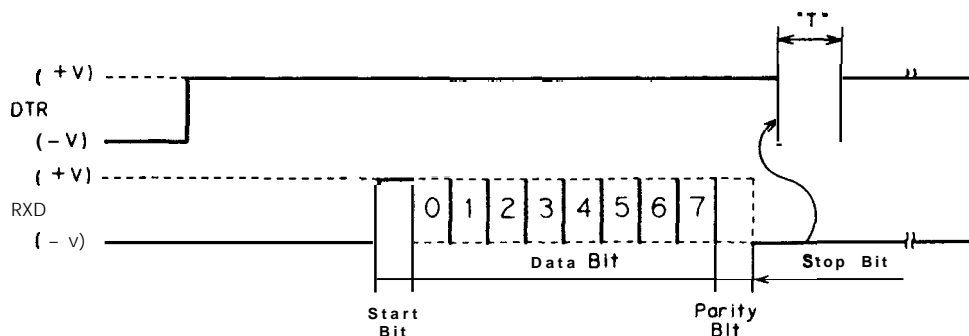

Figure 1-24. DTR Control Handshake Timing

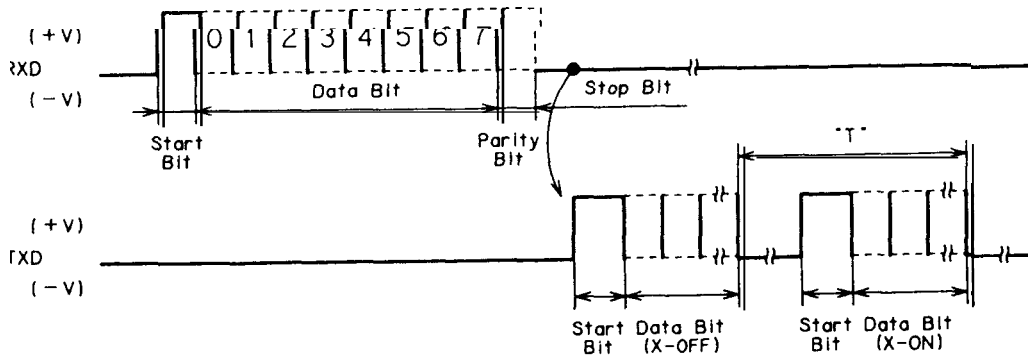

Figure 1-25. XON/OFF Control Handshake Timing

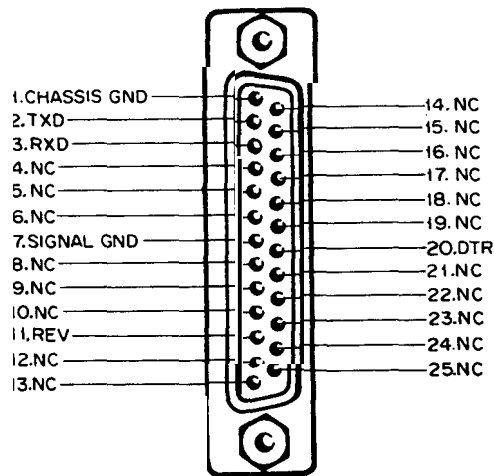

Figure 1-26. EIA Standard 25 Pin Connector

Table 1-9. Serial Interface Pin Assignment

Pin No.	Signal Name	Dir.	Function
1	FG	—	Frame ground
2	TXD	out	Transmit data. XON/XOFF code transmission.
3	RXD	In	Receive data. Inputs data from the host computer.
4-6	—	—	Not used
7	GND	—	Signal ground
8-10	, —	-	INot used
11	DTR	out	Data terminal ready. (Internally connected to pin 20 in parallel mode.)
12-19	—	—	Not used
20	REV	out	Reverse. Has the same function as DTR. (Internally connected to pin 20 in parallel mode.)
21-25	—	—	Not used

## 1.3 OPERATOR CONTROL

This section discusses the operating controls.

### 1.3.1 Control Panel

The control panel is equipped with 7 indicators, 8 switches and a buzzer.

Here, we will discuss the functions of the control panel indicators and switches. Figure 1-27 shows the control panel.

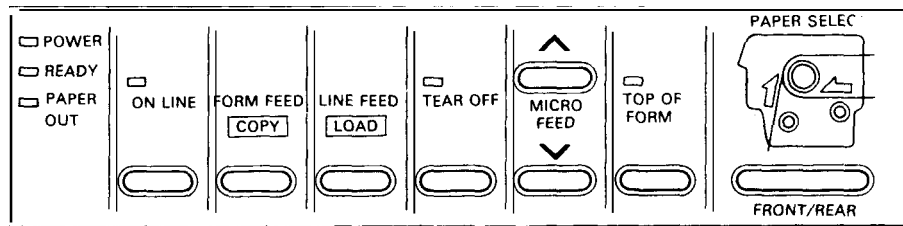

Figure 1-27. Control Panel

The functions of the control panel switches are as follows:

- a. ON LINE: Switches the printer on or off line.
- b. FORM FEED: This mode has the following 2 functions:

(When the paper is to be loaded:)

Functions as an AUTO LOAD switch. If the paper is loaded in the tractor unit and this switch is pressed, the paper automatically advances to the platen. At the same time, the paper is fed from the tractor specified by the "PAPER SELECT" switch.

(When the paper has already been loaded:)

When this switch is pressed when in the off-line mode, the paper is fed to the TOF (TOP OF FORM) position on the next page. The TOF position can be specified in TOF specification mode.

If a FORM FEED is executed at the TOF position, one page length of paper is fed, and if it is performed at any other position, the remaining length of paper is fed. The page length can be specified by:

- Power on reset
- NIT signal reset
- Software reset command: ESC @
- The page length specification command: ESC C
- DIP switch-TOF setting function

When this switch is pressed in the on-line mode, the printer mode is toggled between the "Copy mode" and the "Normal mode". (See section 1.3.15)



The adjusted value is stored in memory on the main board (backed up by battery) by pressing this switch, therefore the TOF position can be reset whenever power is applied. By pressing the "ON LINE" switch, the printer exits from the TOF mode and the adjusted value isn't stored in memory.

— WARNING —

- When label forms are used, TOF should not be used.
- When the optional pull tractor is used, TOF should not be used.

- g. PAPER SELECT:** Available only when the printer is off-line. This function switches between front and rear paper (tractor switching). When the switch is pressed, the currently loaded paper is automatically removed, and paper is loaded from the selected tractor. If the selected tractor has no paper, a "paper end" error will occur. When power is turned off, the tractor that was selected at power-down is selected.

— WARNING —

- When label forms are used, the PAPER SELECT function should not be used.
- Less than one page length of paper should be removed.

The indicators on the control panel have the following functions:

- h. POWER (GREEN):** Lights when AC power is applied and DC power is supplied correctly. The light is connect directly with a +5VDC line. The power switch located at the right side of printer turns AC power to printer on/off.
- i. READY (GREEN):** Lights when the printer is ready to receive data.
- j. PAPER OUT (RED):** Lights when the printer detects a paper end.
- k. ON LINE (GREEN):** Lights when the printer is on-line or in TOF mode and turns off when it is off-line or when printer exits from TOF mode. Flickers during printhead protection mode.
- l. TEAR OFF (GREEN):** Lights when the printer is in TEAR OFF mode.
- m. TOP OF FORM (GREEN):** Flickers when the printer is in TOF mode.
- n. FRONT (GREEN/RED):** Lights green if the paper is loaded during front tractor selection. Lights red if the paper runs out during this selection. When the front tractor is not selected, it does not light.
- o. REAR (GREEN/RED):** Lights green if paper is loaded during rear tractor selection. Lights red if the paper ends during this selection. When the rear tractor is not selected,it does not light.

1.3.2 Self-test Function

This system has a self-test (self-printing) function which checks the following:

- Control circuit
- Printer mechanism
- Print Quality

The self-test for draft characters can be started by applying power while pressing the LF switch. The self-test can be interrupted by pressing the ON LINE switch. Printing is momentarily stopped by pressing the ON LINE switch.

Turn off the power to end the self-test.

The self-test of NLQ characters can be started by pressing the FF switch and applying power.

The self-test prints number the following:

- a. Program ROM version
- b. DIP switch setup
- c. Built-in character set

Figure 1-28 shows the self-test print out.

```

EX2201
Character pitch      Normal          SW1-1 OFF
Shape of zero       Not slashed    SW1-2 OFF
f B table (80H-0FFH) Italic      SW1-3 OFF
Protocol mode       ESC/P mode    SW1-4 OFF
Print quality       Draft         SW1-5 OFF
country             U.S.la.      SW1-6 ON SW1-7 ON SW1-8 ON
Default character   ROM          SW2-1 OFF
Draft print speed   Normal       SW2-2 ON
Serial bit length   8           SW2-3 OFF
Auto LF by CR      Invalid      SW2-4 OFF
Interface          Parallel     SW2-5 OFF SW2-6 OFF
Input buffer       Valid        SW3-1 OFF
Page length (inch) 11          SW3-2 OFF
Skip perforation   Valid        SW3-3 ON
Paper memory       1           SW3-4 OFF
Overlap paper      Invalid      SW3-5 OFF
Paper with label   Invalid      SW3-6 OFF
Ending skip        Invalid      SW3-7 OFF
Serial handshake    DTR         SW3-8 OFF

Frontpaper path    Normal print mode
Normal paper use
Rear paper path    Normal print mode

! " # $ % & ' ( ) * + , - . / 0 1 2 3 4 5 6 7 8 9 : ; < = > ? @ A B C D E F G H I J K L M N O P Q R S T U V W X Y Z [ \ ] ^ _ ` a b c d e f g h i j k l m n o p q r s t u v w x y z {
! " # $ % & ' ( ) * + , - . / 0 1 2 3 4 5 6 7 8 9 : ; < = > ? @ A B C D E F G H I J K L M N O P Q R S T U V W X Y Z [ \ ] ^ _ ` a b c d e f g h i j k l m n o p q r s t u v w x y z {
! " # $ % & ' ( ) * + , - . / 0 1 2 3 4 5 6 7 8 9 : ; < = > ? @ A B C D E F G H I J K L M N O P Q R S T U V W X Y Z [ \ ] ^ _ ` a b c d e f g h i j k l m n o p q r s t u v w x y z {

```

Figure 1-28. Self-test Print out

### 1.3.3 Hexadecimal Dump Function

The hexadecimal dump function prints out the data received by the printer in hexadecimal. On each line, 16 bytes are printed in hexadecimal, and the ASCII character corresponding to each byte is printed on the right side. "." is printed if there is no corresponding character (such as a control code). If less than 16 bytes remain, they can be printed by pressing the ON LINE switch.

By pressing both the LF switch and FF switch and applying power, the printer is set to hexadecimal dump mode and prints "HEX DUMP MODE" on the first line. The power should be turned off to cancel the hexadecimal dump mode.

Figure 1-29 shows a Hexadecimal Dump List.

```
Hex Dump Mode
0000 4C 44 46 4C 44 4D 56 4D 44 46 56 4D 4C 56 46 3B
0020 3B 4D 56 4F 45 45 56 4B 4C 56 46 56 56 4A 44 41
0040 44 4F 41 49 4A 45 4B 56 4E 45 57 49 46 33 34 38
0060 0D 0A 44 43 4C 45 56 46 20 4C 4D 4F 4D 50 54 52
0080 56 4E 20 46 4C 4E 4F 50 4A 51 4A 51 50 4A 42 4F
00A0 4F 49 4A 56 4B 46 4E 20 4E 20 49 48 52 47 56 54
00C0 55 49 52 48 56 45 4B 45 51 56 47 0D 0A 44 43 4C
00E0 35 55 32 38 42 32 20 4A 4E 52 4C 56 4E 20 46 4C
0100 48 56 57 52 54 48 32 50 42 56 57 4F 49 4A 56 4B
0120 55 47 31 39 47 55 33 35 38 35 47 55 49 52 48 56
0140 4D 4F 4D 50 54 52 4A 49 42 34 30 35 55 32 38 42
0160 4A 51 50 4A 42 4F 49 4A 42 57 4E 48 56 57 52 54
0180 49 48 52 47 56 54 4F 47 4A 51 30 55 47 31 39 47
01A0 47 0D 0A 44 43 4C 45 56 46 20 4C 4D 4F 4D 50 54
01C0 4C 56 4E 20 46 4C 4E 4F 50 4A 51 4A 51 50 4A 42
01E0 57 4F 49 4A 56 4B 46 4E 20 4E 20 49 48 52 47 56
0200 47 55 49 52 48 56 45 4B 45 51 56 47 0D 0A 44 43
0220 30 35 55 32 38 42 32 20 4A 4E 52 4C 56 4E 20 46
0240 4E 48 56 57 52 54 48 32 50 42 56 57 4F 49 4A 56
0260 30 55 47 31 39 47 55 33 35 38 35 47 55 49 52 48
0280 4C 4D 4F 4D 50 54 52 4A 49 42 34 30 35 55 32 38
02A0 51 4A 51 50 4A 42 4F 49 4A 42 57 4E 48 56 57 52
02C0 20 49 48 52 47 56 54 4F 47 4A 51 30 55 47 31 39
```

Figure 1-29. Hexadecimal Dump List

1.3.4 DIP Switch Jumper Setup

There are three DIP switches on the front covers at the front of the printer. These set the printer defaults. When power is applied or the printer is reset, the DIP switch selections are treated as the default setup. If the setup is changed, the power should be cycled or the printer should be reset.

Table 1-10 shows the DIP switch selections for this printer.

Table 1-10. DIP Switch Selections

Switch number	Function	ON	OFF	Factory setup
-1	Character mode	Condensed	Normal	OFF
-2	Zero font selection	“o”	“o”	OFF
-3	ESC/P character code table selection	Graphics	Italics	OFF
	IBM mode automatic carriage return with LF (ESC J) selection	Invalid	Valid	
-4	Protocol mode selection (See NOTE: 3)	IBM mode	ESC/P	OFF
-5	NLQ/Draft mode selection	NLQ	Draft	OFF
-6	ESC/P International character set selection	See Table A-11		ON
1-7				ON
1-8	IBM mode default CG table selection			ON
2-1	ESC/P default CG (See NOTE: 4)	User defined	ROM	OFF
	IBM mode form feed enable selection (See NOTE: 7)	Ignore (at TOF position)	Valid	
2-2	Draft print speed mode	Normal	High speed	OFF
2-3	Serial interface data length	7bit	8bit	OFF
2-4	Automatic line feed by CR	Always enabled	External signal control	OFF
2-5	Interface selection	See Table A-1 2		OFF
2-6				OFF
2-7				OFF
2-8				OFF

Table 1-10. DIP Switch Selections (cont'd)

Switch number	Function	ON	OFF	Factory setup
3-1	Input data buffer function	Invalid	Valid	OFF
3-2	Page length setup	12 inches	11 inches	OFF
3-3	Perforation skip function	Valid	Invalid	OFF
3-4	Paper memory selection (See NOTE: 5)	Memory No.2	Memory No. 1	OFF
3-5	Overlapped paper (See NOTE: 5)	Valid	Invalid	OFF
3-6	Label paper (See NOTE: 5)	Valid	Invalid	OFF
3-7	Binding skip (See NOTE: 6)	Valid	Invalid	OFF
3-8	Serial interface handshake mode	XON/XOFF	DTR control	OFF

- NOTES:**
1. The printer power must be off before DIP switches are re-set.
  2. "IBM" or "IBM mode" means IBM Pro-printer emulation mode.
  3. The User-defined characters are backed up in non-volatile memory only in ESC/P mode. When IBM mode is selected by DIP SW 1-4, the user defined characters are deleted. The built-in CG in the ROM is copied to the user-defined area at printer power on when in the IBM mode.
  4. When the user-defined character set is used (by selecting DIP SW 2-1 "ON") as the default character set, ESC & (define character) and ESC : (copy CG) codes are not valid.
  5. These switches are used for paper memory function. (See section xxx)
  6. "Binding skip" is used to print on multi-part form with the "Binding" which scratches the printhead during paper feeding.  
If this switch is set to "ON", the printhead parks apart from those bindings during paper feeding to avoid paper jams.  
Through-put (data process rate) will be reduced while this mode is selected.
  7. The form feed code (OCH) is ignored when the printing line is located at the top of form position and "Ignore mode" is selected with DIP SW 2-1 when in IBM mode.

Table 1-11. Character Set Selection

SW 1-6	Sw 1-7	SW 1-8	Countries (When SW 1-3 "OFF")	Default CG Table (When SW 1-3 "ON")
ON	ON	ON	U.S.A.	CG Table 1
ON	ON	OFF	France	CG Table 2
ON	OFF	ON	Germany	
ON	OFF	OFF	UK	
OFF	ON	ON	Denmark	
OFF	ON	OFF	Sweden	
OFF	OFF	ON	Italy	
OFF	OFF	OFF	Spain	

NOTE: In IBM mode the default CG table is selected by above switches.

"Table 1" means 80 H-9FH codes are control, (same as ESC 7), and

"Table 2" means 80 H-9FH codes are printable. (same as ESC 6)

Table 1-12. Interface Setup

SW 2-5	SW 2-6	Interface selection
OFF	OFF	Parallel interface
OFF	ON	Serial interface -Odd parity
ON	OFF	Serial interface -Even parity
ON	ON	Serial interface -No parity

Table 1-13. Baud Rate

SW 2-7	SW 2-8	Baud rate selection
OFF	OFF	19200 BPS
OFF	ON	9600 BPS
ON	OFF	1200 BPS
ON	ON	300 BPS

Jumper switches are located on the main board (only J 1 is inside of the ROM cover), and are used to select the items listed in Table 1-14.

Table 1-14. Jumper Setup

No.	Function	Short (or "+5" side)	Open	Factory setup
1	SLCT IN signal default setup	Fixed to LOW	Selects external control	Open
2	ROM size select	5 12KB	256KB	Short
3		256KB("+ 5")	5 12KB	Open
4-6	Fixed to "Short"			Short
7	Fixed to "+ 5" side			+ 5

### 1.3.5 Buffer Full Printing

The printer stores the received data in the input data buffer, and prints it when it receives a print command (CR). Printing is also performed when the buffer becomes full.

### 1.3.6 Buzzer

The control panel buzzer sounds at the following times:

When ESC command "BEL" is input:	!	X 1 time
When a paper end is detected:	!!!!	X 5 times (Total 20 times)
When an open cover is detected:	!!!!	X 1 times
When a carriage error is detected:	!!!	X 6 times (Total 18 times)
When an abnormal voltage is detected:	!	X 5 times
When the RAM check detects an abnormality:		
.CPU RAM abnormality:	!!	X 6 times (Total 12 times)
.Lower address RAM abnormality:	!!	X 8 times (Total 16 times)
.Upper address RAM abnormality:	!!	X 10 times (Total 20 times)
When a printhead driver abnormality (short circuited) is detected:	!	X 10 (1 1) times
Short circuited fan transistor:	!!	X 16 times (Total 32 times)
"COPY MODE" selection (press the FORM FEED switch in on line):		
."COPY MODE" is selected:	!	X 2 times
.Normal mode (quit "COPY MODE"):	!	X 1 times
When a paper error is detected:	!	X 3 times
(incomplete paper back-out, or paper empty during paper operation)		
Illegal paper memory setting:	!	X 10 times

### 1.3.7 Error Detection Function

This printer has an error detection function which sets the interface signals to the following states and the unit to the OFF LINE mode. Data cannot be input at this time.

- Parallel interface

BUSY signal: High

ERROR signal: Low

- Serial interface

DTR (REV) signal: MARK

X code (DC code): XOFF (DC3/13H)

The following errors can be detected and the buzzer is used to indicate the error state. (Refer to 1.6.2)

Carriage error:

The carriage home signal is not detected while initializing the printer mechanism, or the carriage home position is detected during printing.

Abnormal voltage:

A low internal DC voltage is detected.

REV.-A

**RAM check abnormality:** During initialization, a READ/WRITE check is performed for all RAM in the control circuit to check for errors.

- CPU RAM
- Lower address RAM
- Upper address RAM

**Printhead driver abnormality:** A short circuit in a printhead drive transistor was detected.

The following states are also regarded as errors, and the interface signals are similarly set.

- When a paper end is detected.
- When an open cover is detected.
- When the printer is set off-line using the ON LINE switch.

### 1.3.8 Paper End Detection Function

Paper end is detected using the paper end sensor on the printer mechanism. When a paper end is detected, the printer indicates it using the lamp and buzzer on the control panel. At this time the interface signals should be set as follows to set the printer to the off-line mode.

This disables data reception.

- Parallel interface
  - BUSY signal: High
  - PE signal: High
  - ERROR signal: Low
- Serial interface
  - DTR (REV) signal: MARK
  - X code (DC code): XOFF (DC3/13H)

When a paper end is detected, new paper should be loaded, or another form should be selected by switching the tractor. The printer should then be set to the on-line mode.

### 1.3.9 Cover Open Detection Function

The printer always monitors the open/close state of the top cover. When the open cover sensor detects an open cover, the following actions occur:

- The printer is set to the off-line mode.
- The buzzer sound.
- Carriage speed is decelerated rapidly.

Opening the cover during printing is extremely dangerous because the carriage moves very rapidly during printing (when the cover is closed). The above actions guarantee the safety of the operator when the cover is opened. To recover from this state, the following sequence should be followed.

[STEP 1] Close the top cover.

[STEP2] Press the ON-LINE switch to set the printer on-line.



### 1.3.10 Automatic Paper Thickness Detection

This printer automatically detects the paper thickness, and adjusts the gap between the platen and printhead when the paper is loaded. Therefore, a platen gap lever adjustment is not required.

### 1.3.11 Automatic Paper Width Detection

This printer detects the paper both edges and determines the left and right margin, which disables printing in areas where no paper exists.

### 1.3.12 Non-volatile User-defined Characters

242 characters can be defined and stored in memory which is backed up by a battery. (once defined they remain in memory even after power-off.)

Characters are selected by DIP switch as the default character set.

**NOTE:** This function is valid only in ESC/P mode. If the protocol mode is changed to IBM mode the defined characters will be lost.

REV.-A

### 1.3.13 Paper Memory Function

This function makes it possible to print properly on forms which contain several areas having different thickness.

- Forms with a label

The area on which the label sticks is thicker than the rest. (Multi-part forms that vary in thickness include forms that have labels on them.)

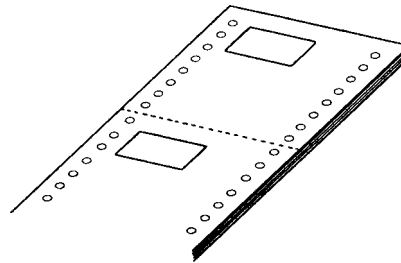

Figure 1-30. Multi-part Forms with Labels

- Multi-part form partly overlapping with the next page

The overlapping area has a doubled thickness. Forms that overlap slightly where they are glued together.

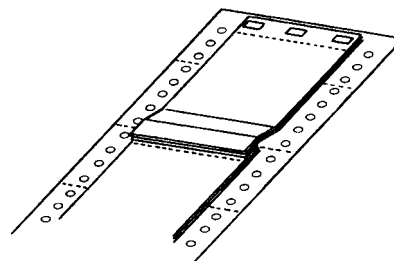

Figure 1-31. Overlapping Multi-part Forms

Information about these areas should be set before printing. The printer works according to this information.

### 1.3.13.1 Using the Paper Memory Feature

This printer can save the paper format and thickness information for up to two multi-part forms in the printer's paper memory areas. This information for a certain form may be recalled and the printer automatically adjusts the gap between the printhead and the platen to provide maximum printing quality on that particular form. The paper memory feature is available only for forms loaded on the front tractor.

#### WARNING

When using multi-part forms that vary in thickness, do not press the TEAR OFF, FRONT/REAR, or reverse-feeding MICRO FEED switch or a paper jam may result.

To remove these forms, tear off the fresh forms off line and then press the FORM FEED or LINE FEED switch to eject the remaining forms.

### 1.3.13.2 Saving Paper Format and Thickness Information

The following sections describe how to save paper format and thickness information for different types of multi-part forms.

#### a. Saving information for overlapping multi-part forms

To save paper format and thickness information for multi-part forms that overlap slightly where they are joined together follow the steps below.

Step 1: Turn off the printer.

Step 2: Use DIP switch 3-4 to select the memory area where you want the printer to store the paper format and thickness information.

Memory area 1 is selected when DIP switch 3-4 is off. This is the printers default setting. To select memory area 2, turn on the switch.

**Table 1-15. Paper Memory Select**

Paper memory	DIP SW 3-4
Memory 1	OFF
Memory 2	ON

Step 3: Use DIP switch 3-2 or software commands to set the page length.

**Table 1-16. Page Length Set**

Page length	DIP SW 3-2
11 inches	OFF
12 inches	ON

REV.-A

**Step 4:** Turn on DIP switch 3-5 and turn off DIP switch 3-6. This tells the printer you want to save information for multi-part forms that overlap slightly where they are joined together.

Table 1-17. DIP SW 3-5 and 3-6

Overlapping multi-part forms	DIP SW 3-5	Multi-part forms with labels	DIP SW 3-6
Valid	ON	Invalid	OFF

**b. Saving information for multi-part forms with labels**

To save paper format and thickness information for multi-part forms with labels on them, follow the steps below:

**Step 1:** Load the forms with labels on to the front tractor.

**Step 2:** Turn off the printer. Be sure to close the top cover.

**Step 3:** Use DIP switch 3-4 to select the memory area where you want the printer to store the paper format and thickness information.

Memory area 1 is selected when DIP switch 3-4 is off. This is the printers default setting. To select memory area 2, turn on the switch.

(See Table 1-1 5.)

**Step 4:** Use DIP switch 3-2 or software commands to set the page length. Page length. (See Table 1-1 6.)

**Step 5:** Turn off DIP switch 3-5 and turn on DIP switch 3-6. This tells the printer you want to save information for multi-part forms with labels on them.

Table 1-18. DIP SW 3-5 and 3-6

Overlapping multi-part forms	DIP SW 3-5	Multi-part forms with labels	DIP SW 3-6
Invalid	OFF	Valid	ON

**Step 6:** Hold down both MICRO FEED buttons and turn on the printer.

The printer loads and checks the forms on the front tractor. When it is done, the printer beeps.

**NOTE:** Do not go on to the next step before the printer beeps.

**Step 7:** Open the top cover.

**Step 8:** Use the MICRO FEED buttons to adjust the paper's position so that the top edge of the label is aligned with the horizontal red line on the clear plastic ribbon mask.

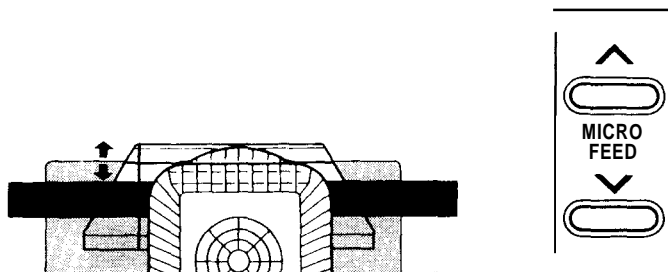

**Figure 1-32. Horizontal Align -Top Edge**

**Step 9:** Move the print head by hand to align the vertical red line on the ribbon mask with the left edge of the label. Now the intersection of the red lines on the ribbon mask should be in the upper left corner of the label.

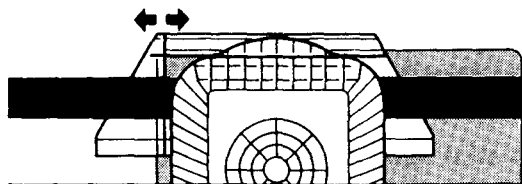

**Figure 1-33. Vertical Align -Left Corner**

**Step 10:** Press the TOP OF FORM button.

**Step 11:** Use the MICRO FEED buttons to adjust your papers position so that the bottom edge of the label is aligned with the horizontal red line on the ribbon mask.

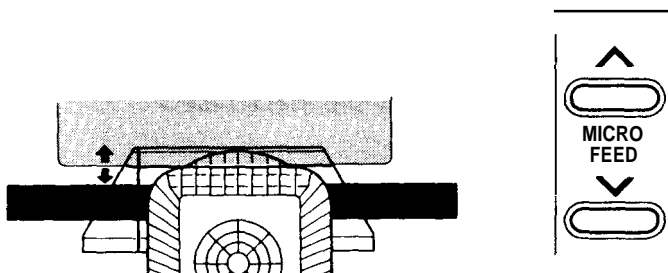

**Figure 1-34. Horizontal Align - Bottom**

REV.-A

**Step 12:** Move the print head by hand to align the vertical red line on the ribbon mask with the right edge of the label. Now the intersection of the red lines on the ribbon mask should be in the lower right corner of the label.

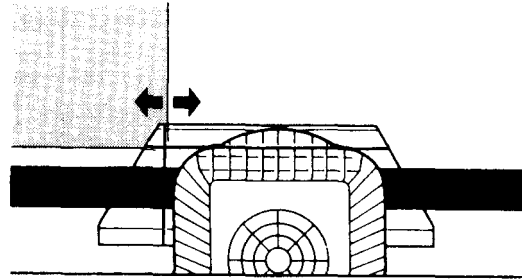

Figure 1-35. Vertical Align -Right Corner

**Step 13:** Press the TOP OF FORM switch. This tells the printer the label's location on the form.

**Step 14:** Close the top cover.

The printer checks the paper's thickness at various points and saves this information. When it is done, the printer beeps and goes off line.

**NOTE:** It takes the printer some time to check and save the paper thickness information.

You can print on these forms even if you turn the printer off and then back on.

To use other types of paper, see the section on loading paper format information from memory later in this section.

**WARNING**

When you print on these forms, make sure that the printing fits within the printable area.

**c. Saving information for overlapping multi-part forms with labels**

To save paper format and thickness information for multi-part forms that overlap slightly and have labels on them, follow the steps below:

**Step 1:** Load the overlapping multi-part forms with labels on to the front tractor.

**Step 2:** Turn off the printer.

**Step 3:** Use DIP switch 3-4 to select the memory area where you want the printer to store the paper format and thickness information.

Memory area 1 is selected when DIP switch 3-4 is off. This is the printers default setting. To select memory area 2, turn on the switch.

(See Table 1-1 5.)

**Step 4:** Use DIP switch 3-2 or software commands to set the page length. The page length is 11 inches when DIP switch 3-2 is off and 12 inches when the switch is on. (See Table 1-1 6.)

Step 5: Turn on DIP switches 3-5 and 3-6. This tells the printer you want to save information for multi-part forms that overlap slightly and have labels on them.

Table 1-19. DIP SW 3-5 and 3-6

Overlapping multi-part forms	DIP SW 3-5	Multi-part forms with labels	DIP SW 3-6
Valid	ON	Valid	ON

Step 6: Follow steps 6 through 14 on section “b”.

#### 1.3.13.3 Loading Paper Format Information from Memory

After you save the information for your multi-part forms, you can load the forms you want to use, select the paper memory feature, and start printing. When you select the paper memory feature, the printer loads the form’s information from memory. To select the paper memory feature, follow the steps below.

Step 1: Load the multi-part forms you want to use on to the front tractor.

Step 2: Turn off the printer.

Step 3: Now load the paper format and thickness information for the multi-part forms you want to use.

To load the information from memory area 1, hold down the top MICRO FEED button and turn on the printer.

To load the information from memory area 2, hold down the bottom MICRO FEED button and turn on the printer.

**NOTE:** After you load the information, the printer will use this information as the default setting when you turn on the printer. To use regular continuous paper after using multi-part forms that vary in thickness, hold down the FRONT/REAR button and turn on the printer.

#### WARNING

While the paper memory feature is selected and your multi-part forms format and thickness information is loaded, do not use other types of paper.

#### 1.3.14 Paper Cutter

An optional paper cutter is available. This paper cutter works when the TEAR OFF switch and the PAPER SELECT switch is pressed while there is paper in the proper paper path.

**TEAR OFF:** Advance the form to the cutting position and cut it.

**PAPER SELECT:** Cut the current form and changes the paper path.

By pressing the TEAR OFF switch during the paper empty state, the cutting position will be initialized. This function is not available when the paper memory function is being used.

For more detail information, please refer to “#C8 1500X PAPER CUTTER UNIT SERVICE MANUAL”.

REV.-A

### 1.3.15 Copy Mode

Hard-stuck characters can be printed on paper such as multi-part forms to get clear characters even on the bottom copy.

This function is selectable from the control panel by pressing the FORM FEED switch in the on-line state. Switch is used to alternate "Copy mode" (beeps twice) and "Normal mode" (beep once).

In this mode, printing speed will be reduced to half of the normal mode speed, and the following pin column prints over the dots printed by the leading pin column.

**NOTE:** This mode is applied only to the normal height draft characters.

(Not condensed, Not emphasized.)

This mode is individually selectable in the front/rear paper path and these selections are not backed up.

### 1.3.16 Printer Initialization

This printer can be initialized in two ways.

#### ● Hardware initialization

A hardware initialization is performed when the power is applied and the interface signal "IN IT" is input (LOW). This operation is as follows:

- . Printer mechanism initialization (Carriage home position seek)
- Sets the printer on-line.
- . Clears the input data buffer.
- . Clears the print buffer.
- . Clears user defined characters.
- . Reads the DIP switch and jumper setup and sets the default conditions.
- Sets the amount of line feeding to 1/6".
- . Clears the vertical tab positions.
- Sets the horizontal tab positions to every 8 characters.

#### ● Software initialization

Control code ESC @ performs a software initialization of the printer. The differences between software initialization and hardware initialization are as follows:

- . The printer mechanism is not initialized.
- The input data buffer is not cleared.
- The TEAR OFF and TOP OF FORM positions are not reset.
- The DIP switch and jumper setup are not read or reset.



## 1.4 MAJOR UNITS

The DFX-8000 consists of the following major units:

- Printer mechanism                    Model-3C65
- Power supply board                BOPS board (AC 120V version)
- BOPSE board (AC 220/240V version)
- Main board                            C030MAIN board
- Driver board                         C030DRV board
- Control panel
- Housing

### 1.4.1 Printer Mechanism Model-3C65

The Model-3C65 is a 9 pin 2 lows (Total 18 pin) serial dot matrix printer mechanism developed for the DFX-8000. This design places emphasis on high speed printing and endurance, and is a heavy duty design when compared with existing terminal printer mechanisms. Its paper feeding mechanism is designed to use fan-fold paper and an automatic mechanism is equipped to enhance paper handling. Table 1-20 listed major components consists the Model-3C65.

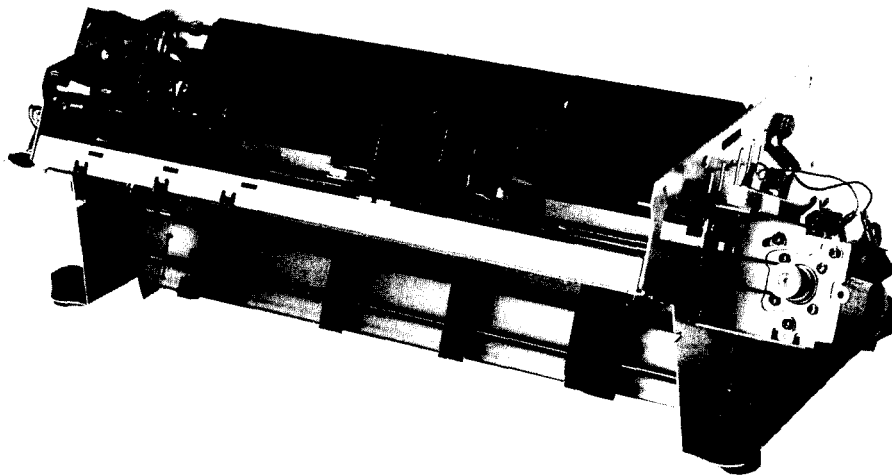

Figure 1-36. Model-3C65 Printer Mechanism

Table 1-20. Major Components of Model-3C65

Component Name	Description
Printhead	9pins x 2lows/ Spring Charge Method dot impact head/ 36.5VDC
Head Cooling Fan	2-phases/ 6-poles/ PM type Stepping motor/ 32.5VDC (built-in with printhead)
External Fan	DC Brushless motor/ 36.5VDC
Carriage Motor	DC Servo motor/ 36.5VDC/ ● CR motor
Paper Feed Motor	4-phases/ 200-poles/ HB type Stepping motor/ 36.5VDC/ * PF motor
Platen Gap Motor	4-phases/48-poles/PM type Stepping motor/36 .5VDC/ •PG motor
Ribbon Feed Motor	4-phases/48-poles/PM type Stepping motor/36 .5VDC/ •RF motor
Loading Solenoid	DC Solenoid Coil/36.5VDC
Carriage Encoder	Photo Interrupter/5VDC (built-in with carriage motor)
Carriage Home	Photo interrupter/5VDC/*CHPS
Position Sensor	
Paper Thickness Sensor	Photo Interrupter/5VDC/*PT sensor
Paper End Sensor	Photo Interrupter/5VDC/
(Front side)	•Front PE sensor
(Rear side)	•Rear PE sensor
Paper End sensor	Reflection type Photo Interrupter/5VDC
(Paper bail top position)	‘ Top PE sensor
Paper Width Sensor	Reflection type Photo Interrupter/5VDC/ *PW sensor
Tractor Select	Mechanical switch/5VDC ● T switch
Sensor Switch	
Pull Tractor	Mechanical switch/5VDC ● PT switch
Sensor Switch	

#### 1.4.2 Power Supply Board Unit

The BOPS and BOPSE board is a power supply circuit which supplies the control circuit (Main board) and printer mechanism drive circuit (Driver board) with power.

The BOPS board is an AC 120V version, the BOPSE board is for AC 220 and 240 V. The circuit of both boards is same without the primary side circuit.

Table 1-21 listed major components of the power supply board.

Table 1-21. Major Components of the **BOPS/BOPSE** Board

Location	Component Name	Description
IC1	TL594	PWM switching regulator controller
IC4,IC5	NJM2903D	Error amplifier
IC2,IC3	NJ M2904D	Error amplifier
Q3,Q8	TL5431	High precision shunt regulator
Q1,Q2	2SK 1167	FET/450V, 15A, 100W
Q4	2SC3456	FET transistor/800V, 1.5A, 40W
Q5	2SC2655	FET transistor\50V, 2A, 900mW

1.4.3 Main Board

The C030MAIN board is the main board in this system. The parallel and serial interfaces, control circuit and sensor circuit are located on the C0303MAIN board.

Table 1-22 listed major components of the main board.

Table I-22. Major Components of the C030MAIN Board

Location	Component Name	Description
5E	μPD78322L	CPU/8 bit data bus/Built-in mask ROM/A-D converter
4C	HM6264	SRAM/64KB
ID	SN75 188N	RS-232C line driver/TTL
1E	SN75 189N	RS-232C line driver/TTL
CR1	CSA2.00MK	Ceramic oscillator/2MHz
CR2	CST14.74MXW00 1	Ceramic oscillator/1 4.74 MHz
BAT 1	CR 17335SE-FTI	Litium battery
2E	E05A16GA	Gate array/Mechanism control/Control panel
6A	E05A38NA	Gate array/interface/MMU/Head control

NOTE: “MMU” Memory Management Unit

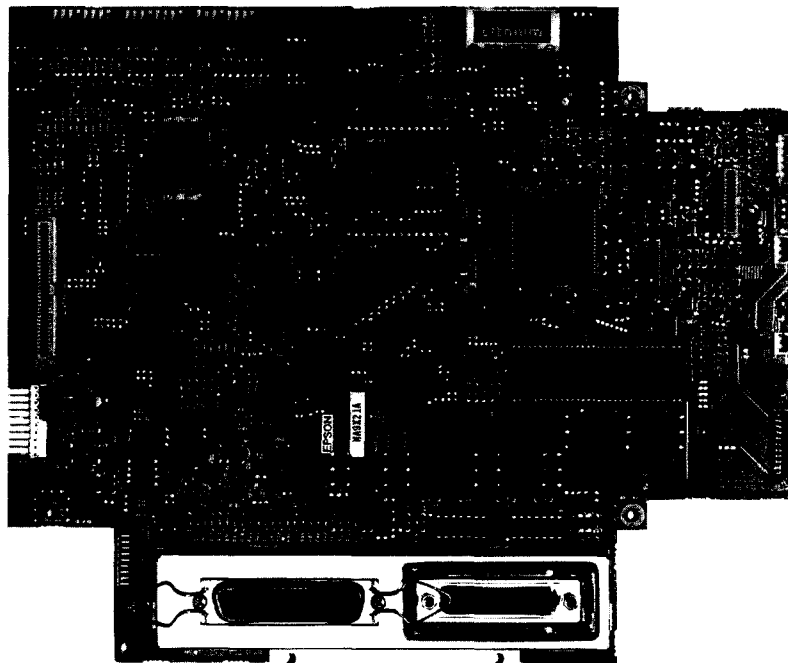

Figure 1-39. C030MAIN Board

1.4.4 Driver Board

The C030DRV board is the driver board in this system. The Printhead, Head cooling-fan, Plunger, Paper feed motor, Carriage motor, PG motor and RF motor driver circuit are located on the C0303DRV board. Sensor signals from the printer mechanism are connected to the main board via this board. Table 1-23 listed major components of the main board.

Table 1-23. Major Components of the C030DRV Board

Location	Component	Name Description
1 A-3A	LB1214	Transistor array\ 35 V,200A,960mW/Printhead drive
4B,4C,4D	STK66025	Hy-blidIC/Printhead drive
2B,2C,2D	STK66 125	Hy-blidIC/Printhead drive
4E	STK6885H	Hy-blid IC/Carriage motor drive
2E	STK67 13BMK2	Hy-blidIC/Paper feed motor drive
Q4,Q6	2SB794	Transistor/-60V,-I .5A, 10W/PG,RF motor drive
Q14	2SB885	Transistor/- 100V,-5A,35 W/Plunger drive
Q2	2SC3746	Transistor/60 V,5A,20W\External fan motor drive
Q3,Q5,Q19	2SD 1395	Transistor/50V,5 A,40W\Head cooling fan motor, Plunger drive
Q 10-13	2SD 1843-T	Transistor/60V, 1 A, 1 W/PG,RF motor drive
Q1 5-18		

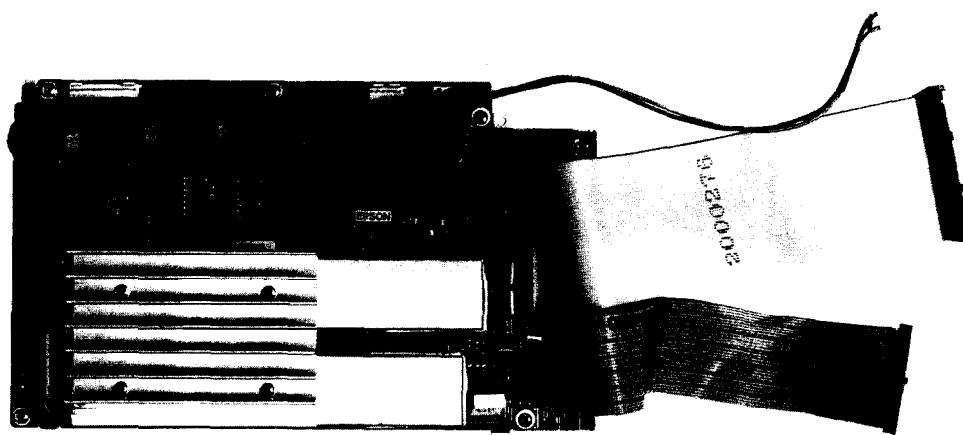

Figure 1-40. C030DRV Board

REV.-A

### 1.4.5 Control Panel

Figure 1-41 is the operator control panel containing switches, LEDs and buzzers.

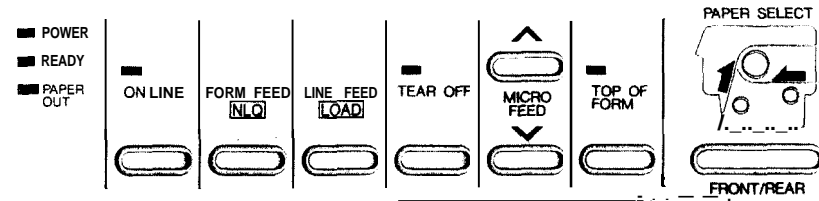

Figure 1-41. Control Panel

### 1.4.6 Housing

The housing used in this system consists of many more components than previous designs. The lower case is used as the main frame which holds the mechanism and circuits, and they are covered by the upper case, bottom plate and side cover, each of which has various covers. The housing has large openings in both the front and rear for paper entrance and exit. It also has a lid on the bottom plate to enable the PROM on the main board to be easily replaced.

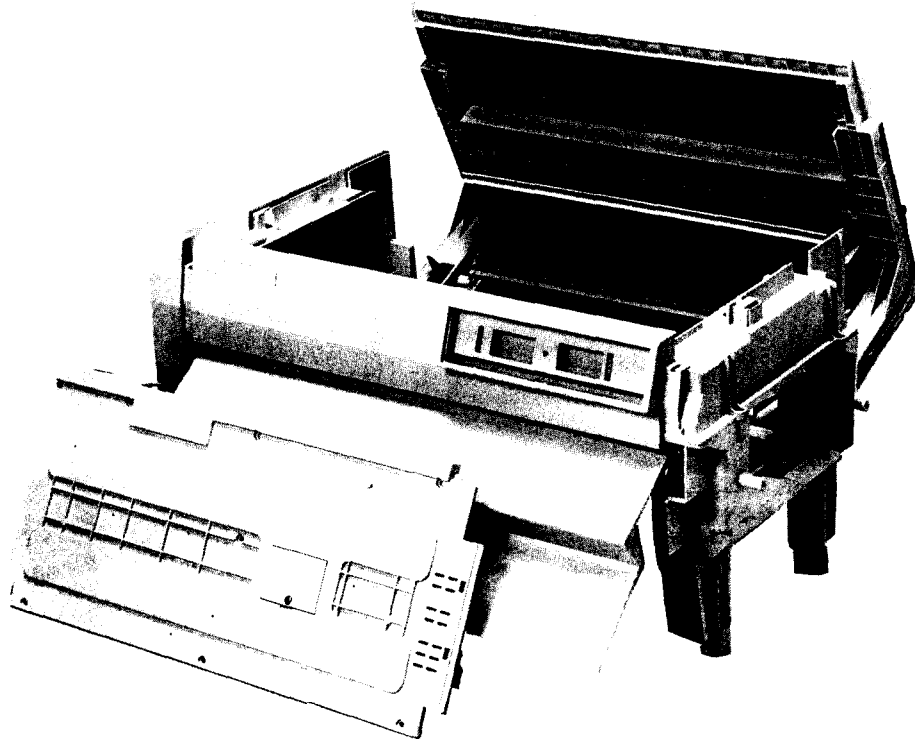

Figure 1-42. Housing

# CHAPTER 2

## OPERATING PRINCIPLES

2.1 GENERAL PRINTER MECHANISM OPERATION .....	2-1
2.1.1 <b>Printhead</b> Mechanism .....	2-1
2.1.2 Carriage Mechanism .....	2-3
2.1.3 Platen Gap Adjustment Mechanism .....	2-6
2.1.4 Ribbon Feed Mechanism .....	2-7
2.1.5 Paper Feed Mechanism .....	2-8
2.1.6 Paper Width Detection Mechanism .....	<b>2-14</b>
2.2 POWER SUPPLY CIRCUIT .....	2-15
2.2.1 DC Voltages and Applications .....	<b>2-16</b>
2.2.2 Power Supply Circuit Operation .....	2-17
2.3 CONTROL CIRCUIT .....	2-20
2.3.1 Interface Circuit .....	2-23
2.3.2 Reset Circuit .....	2-24
2.3.3 Memory Backup Circuit .....	2-25
2.3.4 A-D Converter Detection Circuit .....	2-27
2.3.5 Interrupt Port Detection Circuit .....	2-29
2.3.6 Detection Circuits Connected to the General-purpose Ports .....	2-30
2.3.7 Ribbon Feed Motor/External Fan Control/ Drive Circuit .....	2-32
2.3.8 Paper Feed Motor Control/Drive <b>Curcuit</b> .....	2-33
2.3.9 Platen Gap Motor Control/Drive Circuit .....	2-34
2.3.10 Carriage Motor Control/Drive Circuit .....	2-37
2.3.11 <b>Printhead</b> Control/Drive Circuit .....	<b>2-40</b>

## LIST OF FIGURES

Figure 2-1.	Printedhead Operating Principle .....	2-1
Figure 2-2.	Carriage Mechanism .....	2-4
Figure 2-3.	Inter-lock Mechanism .....	2-5
Figure 2-4.	Platen Gap Adjustment Mechanism .....	2-6
Figure 2-5.	Ribbon Feed Mechanism Operation .....	2-7
Figure 2-6.	Tension Roller and Platen Roller Operation .....	2-8

Figure 2-7.	Front Tractor Operation .....	2-9
Figure 2-8.	Rear Tractor Operation .....	2-9
Figure 2-9.	Platen Grooves .....	<b>2-11</b>
Figure 2-10.	Plunger Mechanism .....	<b>2-12</b>
Figure 2-11.	Tractor Select Mechanism Operation .....	2-1 3
Figure 2-12.	Paper Width Detection Mechanism .....	2-14
Figure 2-13.	Power Supply Section Block Diagram .....	2-1 9
Figure 2-14.	Control Circuit Block Diagram .....	2-22
Figure 2-15.	Interface Circuit Block Diagram .....	2-23
Figure 2-16.	Reset Circuit Block Diagram .....	2-24
Figure 2-17.	Memory Backup Circuit Block Diagram .....	2-26
Figure 2-18.	A-D Converter Detection Circuit .....	2-28
Figure 2-19.	CPU Interrupt Port Detection Signal Assignment .....	2-29
Figure 2-20.	General-purpose Ports Assigned to Detect Signals .....	<b>2-31</b>
Figure 2-21.	Ribbon Feed Motor Control/Drive Circuit Block Diagram .....	2-32
Figure 2-22.	Paper Feed Motor Drive Modes .....	2-33
Figure 2-23.	PG Motor Control/ Drive Circuit Block Diagram .....	2-34
Figure 2-24.	Platen Gap Setup Sequence .....	2-35
Figure 2-25.	Platen Gap Setup Conceptual Diagram .....	2-36
Figure 2-26.	Carriage Control/ Drive Circuit Block Diagram .....	2-39
Figure 2-27.	<b>Printhead</b> Control/ Drive Circuit Block Diagram .....	2-41
Figure 2-28.	<b>Printhead</b> Drive Circuit Block Diagram .....	2-41

## LIST OF TABLES

Table 2-1.	<b>Printhead</b> Unit Specifications .....	2-2
Table 2-2.	Carriage Motor Specifications .....	2-4
Table 2-3.	External Fan Specifications .....	2-4
Table 2-4.	Platen Gap Motor/Sensor Specifications .....	2-6
Table 2-5.	Ribbon Motor Specifications .....	2-7
Table 2-6.	Paper Feed Motor Specifications .....	2-10



Table 2-7. Pull Tractor Sensor ..... 2-10

Table 2-8. Paper End Sensor Specifications ..... 2-10

Table 2-9. Plunger Mechanism ..... 2-11

Table 2-10. Tractor Select Sensor Specifications ..... 2-13

Table 2-11. Paper Width Detector Specification ..... 2-14

Table 2-12. Power Specifications ..... 2-14

Table 2-13. DC Voltages ..... 2-14

Table 2-14. Power-on Reset Status ..... 2-24

Table 2-15. Operation of Each Element in the  
Memory Backup Circuit ..... 2-25

Table 2-16. Battery Specifications ..... 2-25

Table 2-17. A-D Converter Port Functions ..... 2-27

Table 2-18. Interrupt Detection Signal Functions ..... 2-29

Table 2-19. General-purpose Ports Assigned to Detect  
Circuit Monitors the IC ..... 2-30

Table 2-20. Ribbon Feed Motor Control/  
Drive Circuit Specifications ..... 2-32

Table 2-21. Paper Feed Motor Control/  
Drive Circuit Specifications ..... 2-33

Table 2-22. PG Motor Control/  
Drive Circuit Specifications ..... 2-34

Table 2-23. Carriage Motor Control/  
Drive Circuit Specifications ..... 2-38

Table 2-24. Control Mode Circuit Operation ..... 2-38

Table 2-25. Printhead Control/Drive Circuit  
Specifications ..... 2-42

## 2.1 General Printer Mechanism Operation

This chapter will describe the functions and operating principles of printer mechanism operation.

### 2.1.1 Dot Matrix Mechanism

The dot matrix mechanism is composed of a magnetic coil, ink ribbon, and ribbon mask. The control circuit is a spring-charge impact dot matrix. Figure 2-1 shows the operating principle of the dot matrix printer.

- a. Portion A of the dot wire is attached to the actuating spring plate, and is pulled back (RIGHT in the figure) by magnetic force (M) when the printer power is off and when the printer is in the standby state. Therefore, the actuating spring plate is bent backward by the M force.
- b. When the magnetic coil is energized, a countermagnetic force (C) is induced in the core, the total magnetic force on the actuating spring plate becomes zero, and the actuating plate returns to its original shape. At this time, the dot wire is pushed forward and strikes the platen via the ink ribbon and paper, which prints a dot on the paper.
- c. When the coil is deenergized, the dot wire returns to the state described in "a".

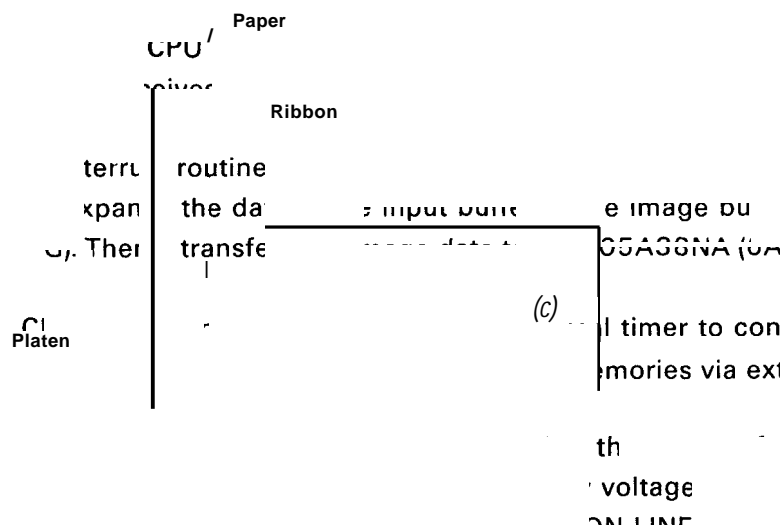

Figure 2-1. Operating Principle

The above described operation is performed for each dot wire. Each dot wire has its own drive circuit which independently controls energizing of the coil.

The 18 dot wires are arranged as two vertical rows of 9 pins. Therefore, twice the speed of a normal 9-pin printer can be obtained by driving the two 9-pin rows. (Both 9-pin rows may be driven at the same time depending on the character construction or printing mode).

In the copy mode, the characters printed by the first row are printed again by the second

### 3.4 A-D fan

The CPU is cooled by two fans, the A-D fan and the external fan.

The CPU fan is integrated with the converter and is turned on when the temperature sensor incorporated in the change-over coil detects a certain A-D temperature. The fan also monitors its own motor temperature and cuts current to the motor if the temperature rises abnormally, to prevent damage due to overheating.

The fan unit specifications are shown below:

Table 2-1. Fan Unit Specifications

Fan Specifications		Fan Specifications	
Printing method	Spring charge type impact printing	Type	2-phase 6-pole PM-type cooling motor centrifugal fan
Number of wires	18 (9 wires X 2 rows)	Supply voltage	32.5 to 35.0 V
Wire diameter	0.29 mm	Coil resistance	61 ± 4.3 ohms/phase (at 20°C)
Life of fan	400 million strokes/wire	Drive frequency	to 50 Hz
Weight	352 g	Rotational direction	to the DIP is undefined
Coil resistance	2.93 ± 0.2 ohms (at 20°C)	Excitation system	1-1 phase excitation
Drive period	Typical – 417 or more Min. – 397		
Drive voltage	35.5 to 37.5		
Insulation resistance	500 ± 100 M ohms or more		
Environmental conditions	Temperature – 5 to 55°C Humidity – 10 to 85		

### 2.1.2 Carriage Mechanism

The carriage mechanism is composed of a carriage motor unit (carriage motor and encoder) and home position sensor. The interlock mechanism and external fan are also described here.

Figure 2-2 shows the carriage mechanism.

The carriage is supported by the two carriage guide shafts. The rotation of the carriage motor is transmitted to the carriage timing belt through the carriage belt pulleys on the right and left sides. The carriage on which the mission gear is mounted is fixed to the timing belt, and moved horizontally. Since the timing belt is tensioned by the motor, the tension can be adjusted by shifting the motor mounting position.

The carriage home position sensor generates a signal when the sensor plate attached to the bottom of the carriage blocks the beam from the photo interrupter (sensor).

The speed and position of the carriage motor are detected by the carriage motor encoder and carriage home position sensor, respectively. The carriage motor is closed-loop controlled.

The encoder unit is integrated with the carriage motor and generates pulses. The encoder plate has equal-pitched slits and is mounted on the C with the carriage motor rotor. The photo interrupter (encoder) is placed so that the light emitting and receiving portions are divided by the outer circumference of the encoder plate, which contains the slits, and converts the motor rotational speed into photoelectric pulses. Since the signals from the encoder are fed back to the CPU, the carriage can be moved or held at any position and the carriage motor speed can be controlled.

● External fan

The printer is cooled by two fans: the mechanism fan and the external fan. The external fan is placed at the left side of the carriage mechanism and is always operating during printing. If the temperature rises abnormally, the printer enters the printing halt or standby state (hot head mode), and the carriage is returned to the home position and cooled by the external fan.

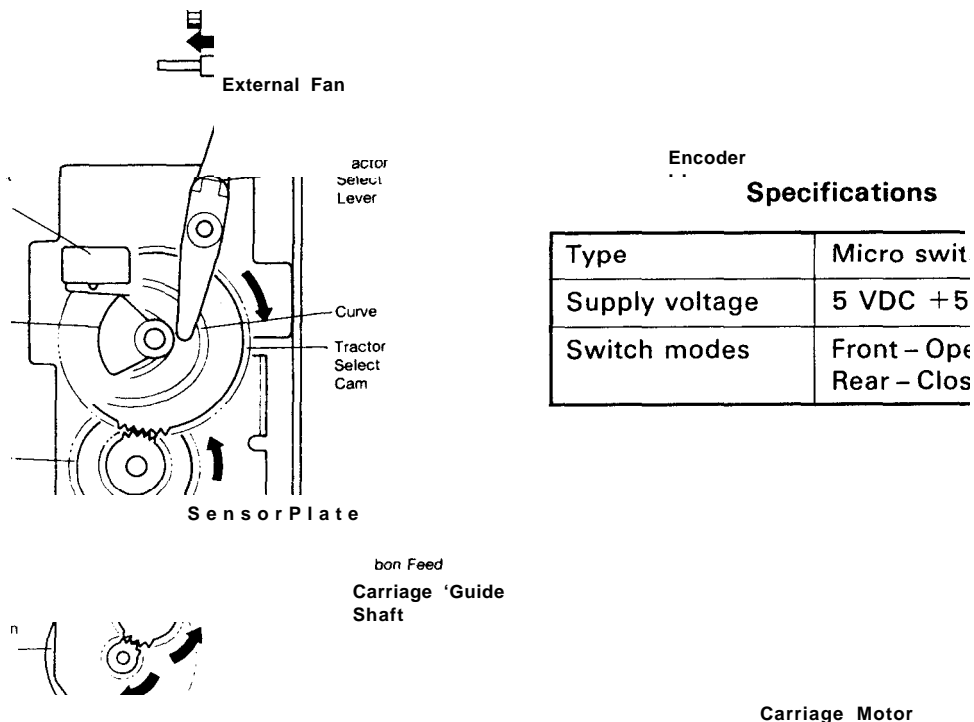

Figure 2-2. Carriage Mechanism

Table 2-2. Carriage Motor Specifications

Carriage Motor Specifications		Encoder Specifications	
Type	DC servo motor	Light emitting element	LED
Supply voltage	36.5 VDC + 1 V	Light receiving element	Photo diode
Armature resistance	2.13 ohms (at 25°C)	Supply voltage	5 VDC $\pm$ 5%
		Output waveform	2-phase rectangular pulses (TTL level) (Phase difference: 90°)
		Resolution	288 slits (see NOTE)
		Response frequency	15 kHz

NOTE: In the case of actual carriage operation, one slit is equivalent to 1/120 inch.

Table 2-3. External Fan Specifications

Type	DC brushless motor (including ball bearings)
Supply voltage	36.5 VDC $\pm$ 1 V
Fan resistance	400 $\pm$ 20 ohms
Coil resistance	220 $\pm$ 20 ohms
Rotational speed	5700 rpm

**● Interlock mechanism**

Since the carriage moves at very high speed in the printer mechanism, it would be dangerous if a hand or finger was inserted into the mechanism during printing.

When the top cover is opened, the interlock mechanism cuts the drive voltage to the carriage motor to stop the motor and prevent accidents.

Figure 2-3 shows the interlock mechanism.

When the top cover is closed, the hinge of the cover presses the interlock switch. The switch is closed, and the end of the current cut resistor is shorted.

When the top cover is opened, the interlock switch is opened, and drive current to the carriage motor is cut. In this way, the carriage operation is stopped.

When the top cover is opened, the cover open sensor also detects the "OPEN" state to prevent software problems.

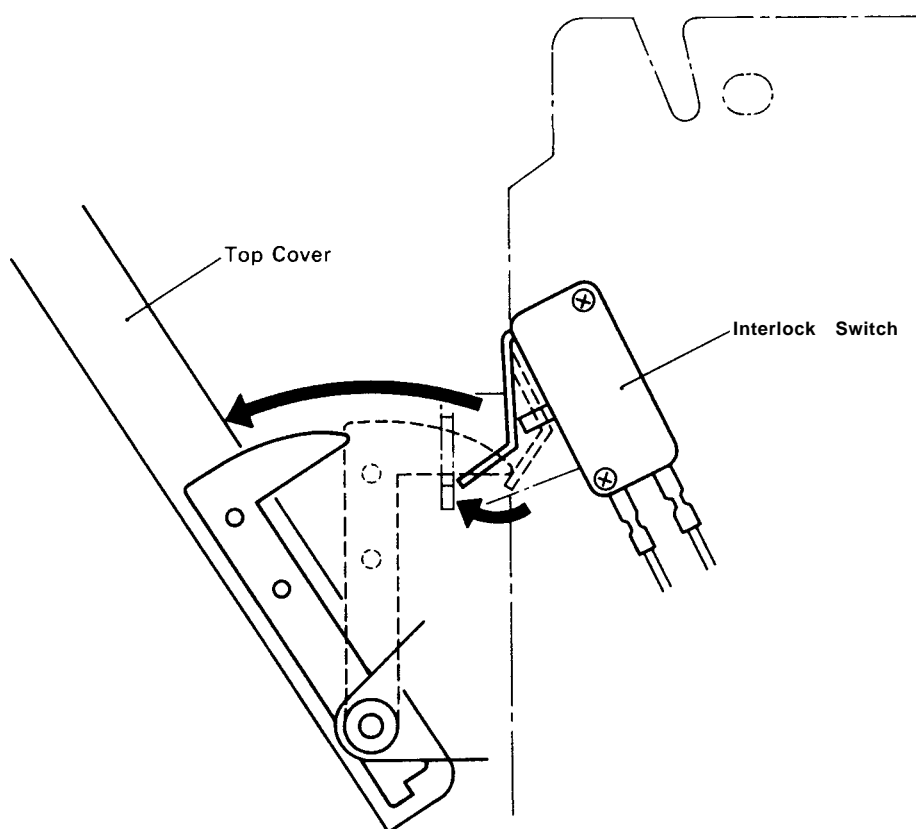

Figure 2-3. Inter-1ock Mechanism

2.1.3 Platen Gap Adjustment Mechanism

The printer mechanism has an automatic platen gap adjustment function that ensures an optimum gap (between the platen and printhead) by measuring the thickness of the paper.

Figure 2-4 shows the platen gap adjustment mechanism.

The carriage guide shaft supporting the front of the carriage has an elliptical section. The rotation of the platen gap motor is transmitted to the carriage guide shaft through the gears. Counterclockwise (CCW) rotation of the motor expands the platen gap and clockwise (CW) rotation reduces it (as viewed from the left side).

An encoder plate with equally-pitched slits is mounted coaxially with the rotor of the platen gap motor. When the motor rotates, the platen gap sensor (photo coupler) detects it and outputs pulses. Each pulse corresponds to 0.015 mm (horizontal distance), and the detection range is 0 to 0.7 mm.

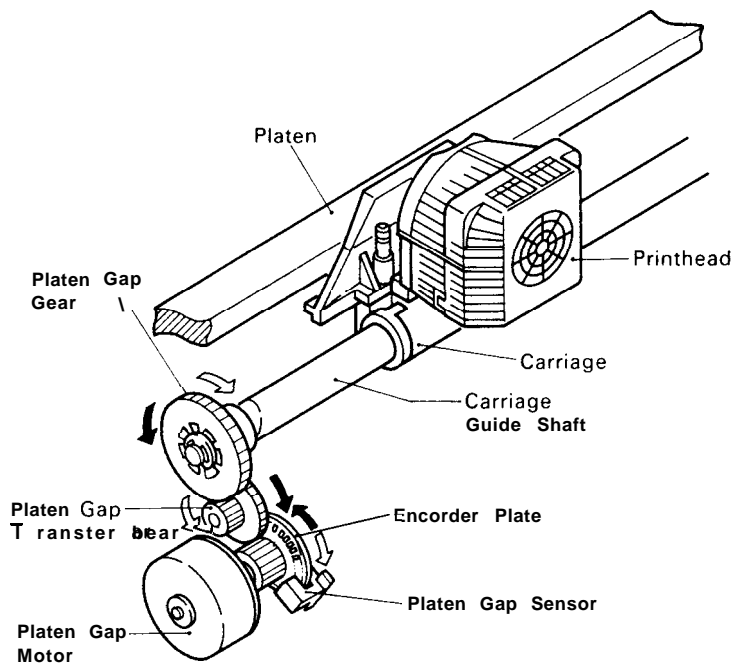

Figure 2-4. Platen Gap Adjustment Mechanism

Table 2-4. Platen Gap Motor/Sensor Specifications

Motor Specifications		Sensor Specifications	
Type	4-phase 48-pole PM-type stepping motor	Detector	Photo interrupter
Supply voltage	36.5 ± 1 VDC	output	2-channel rectangular pulse (TTL level)
Winding resistance	250 ± 18 ohms/phase (at 25°C)	Supply voltage	5 VDC ± 5%
Drive frequency	285 pps	Phase difference	Approx. 45°
Excitation system	2-2 phase excitation		

2.1.4 Ribbon Feed Mechanism

The ink ribbon is an endless loop. The ribbon feed mechanism takes up the ribbon, and is driven by the ribbon motor.

Figure 2-5 shows the ribbon feed mechanism operation. The ribbon is fed in one direction only. The rotation of the ribbon motor (counterclockwise) is transmitted to the ribbon feed gear (clockwise) through the ribbon feed select gear and ribbon feed transmission gear. The tip of the ribbon feed gear engages the ribbon cartridge take-up roller to feed the ribbon.

The ribbon motor supplies mechanical power to both the ribbon feed mechanism and tractor select mechanism. As the ribbon motor pinion rotates, the ribbon feed select gear swings like a pendulum, using the lever axis as a fulcrum, and the rotation of the motor is transmitted to either mechanism when the gears are engaged. When the ribbon motor rotates counterclockwise, the rotation of the motor is transmitted to the ribbon feed mechanism, and when it rotates clockwise, it is transmitted to the tractor select mechanism.

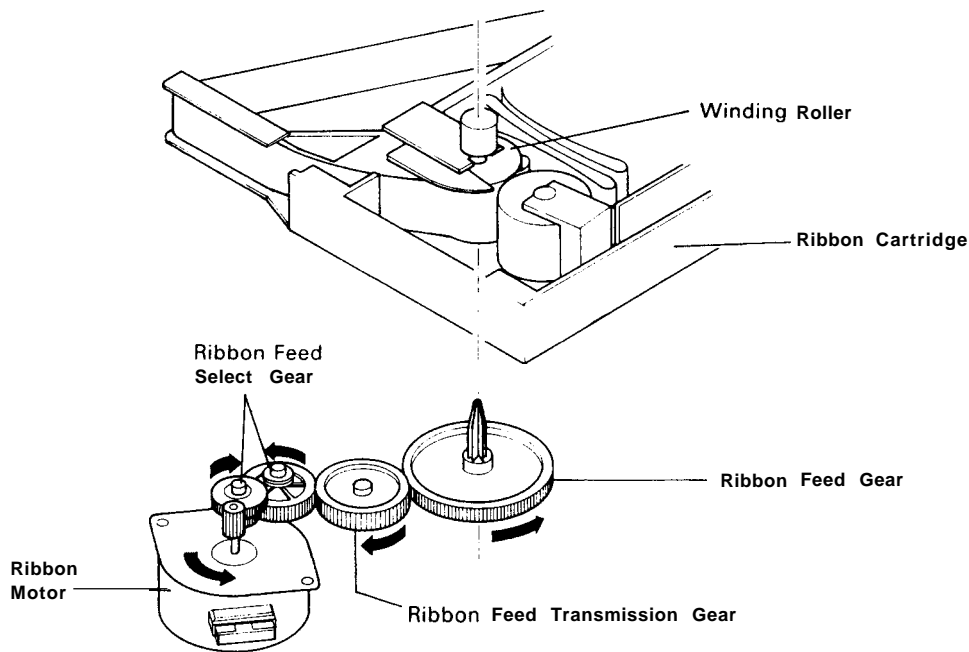

Figure 2-5. Ribbon Feed Mechanism Operation

Table 2-5. Ribbon Motor Specifications

Type	4-phase 48-pole PM-type stepping motor
Supply voltage	36.5 ± 1 VDC
Winding resistance	150 ± 10 ohms/phase (at 25°C)
Drive frequency	720 pps
Excitation svstem	2-2 phase excitation



### 2.1.5 Paper Feed Mechanism

The paper feed mechanism is composed of a paper feed motor, tractor, paper-end sensor mechanism, pull tractor sensor, plunger mechanism, and paper selection mechanism.

Figures 2-6 to 2-8 shows the paper feed mechanism.

After the paper is loaded, it is fed by the tension roller, platen roller, and front/rear tractor. The rotation of the paper feed motor is always transmitted to the tension roller and platen roller (Figure 2-48), but it is transmitted alternately to the front and rear tractors.

The rotation of the paper feed transmission gear is transmitted through the paper feed select gear which is designed to always engage with one of the tractor trains. Which tractor train the tractor select gear engages is selected by the tractor select mechanism.

The paper end sensors always detects whether the paper is loaded or not. In this printer, a total of three paper-end sensors are installed at the front and rear tractors and paper bail.

The front and rear paper-end sensors are incorporated in the sprocket unit. When paper is loaded, the paper pushes the leaf spring so as to block the photo-interrupter. When no paper is loaded, the photo-interrupter is not blocked.

The upper paper-end sensor is attached to the upper paper guide and is used together with the reflection plate on the paper bail. When the paper is loaded, the paper blocks the beam between the photo-interrupter and reflection plate.

When no paper is loaded, the beam is not blocked.

The pull tractor sensor monitors whether the optional pull tractor is mounted or not. When the pull tractor is mounted, the tear off function is disabled to prevent paper jams.

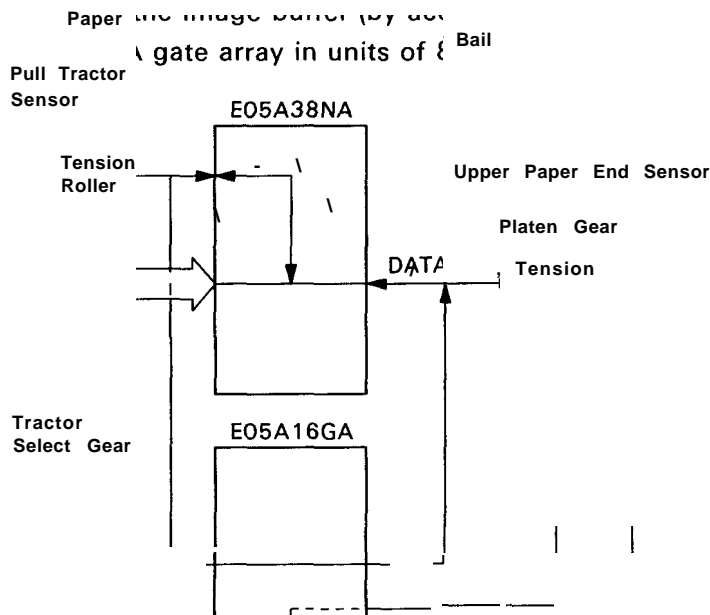

Figure 2-6. Tension Roller and Platen Roller Operation

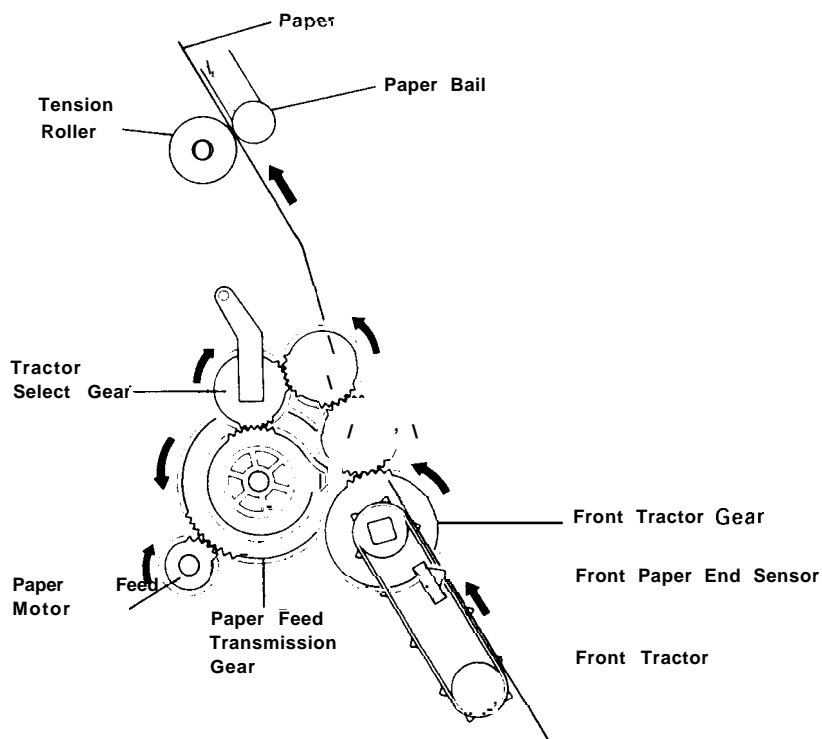

Figure 2-7. Front Tractor Operation

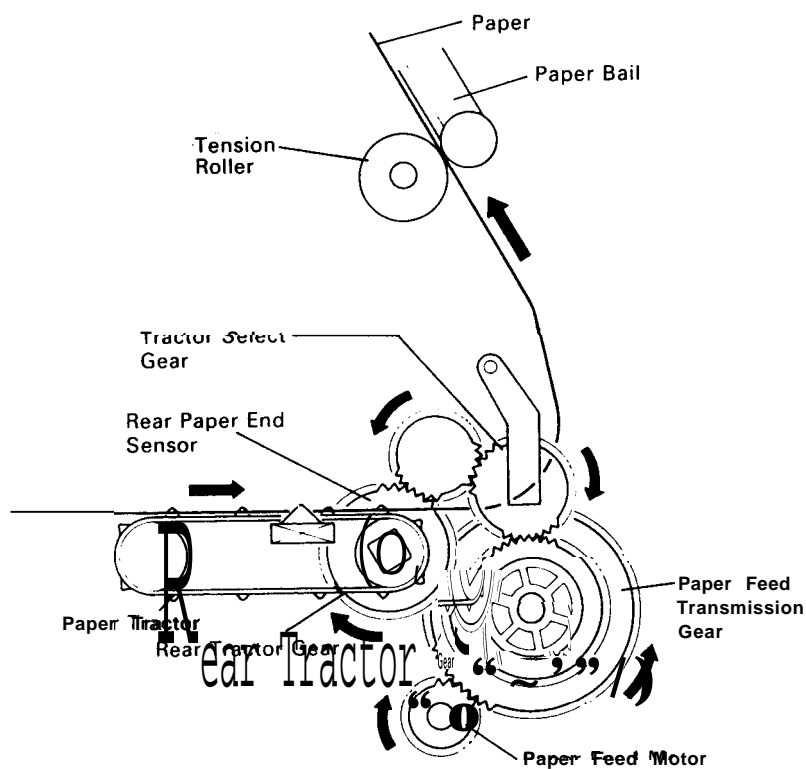

Figure 2-8. Rear Tractor Operation

Table 2-6. Paper Feed Motor Specifications

<b>Type</b>	<b>4-phase 200-pole HB-type stepping motor</b>
<b>Supply voltage</b>	<b>36.5 ± 1VDC</b>
<b>Winding resistance</b>	<b>2.85 ± 0.3 ohms</b>
<b>Drive frequency</b>	<b>2610 pps (medium speed mode) 4274 pps (high speed mode)</b>
<b>Excitation system</b>	<b>1-2 phase excitation</b>

Table 2-7. Pull Tractor Sensor Specifications

<b>Type</b>	<b>Micro switch</b>
<b>Supply voltage</b>	<b>5 VDC ± 5%</b>
<b>Switch mode</b>	<b>Unmounted -Open (OFF) Mounted -Closed (ON)</b>

Table 2-8. Paper End Sensor Specifications

<b>Sensors at the Front/Rear Tractor</b>		<b>Sensor at the Paper Bail</b>	
<b>Detector</b>	<b>Photo-interrupter</b>	<b>Detector</b>	<b>Photo reflector</b>
<b>Output type</b>	<b>Open collector</b>	<b>Output type</b>	<b>Open collector</b>
<b>Supply voltage</b>	<b>5 VDC ± 5%</b>	<b>Supply voltage</b>	<b>5 VDC &amp; 5%</b>
<b>Signal mode</b>	<b>With paper - HIGH Without paper - LOW</b>	<b>Signal mode</b>	<b>With paper - HIGH Without paper - LOW</b>

There are grooves at both ends of the platen, which are to prevent paper jams caused by paper chips from the sprocket holes in continuous paper or fringes produced when pressing copy paper so that it will not be separated. Since the continuous paper is fed at high speed, the paper chips or fringes could get caught between the ribbon mask and platen and cause a paper jam. The grooves work as margins for the paper thickness.

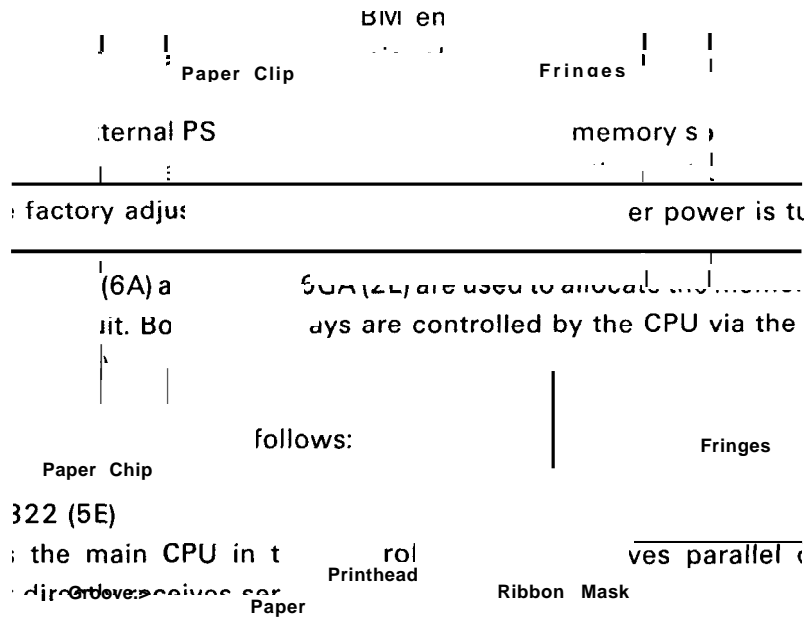

Figure 2-9. Platen Grooves

REV.-A

● **Plunger mechanism**

During printing, the paper is pushed against the platen by the paper bail so that the paper does not float away from the platen. However, when paper is loaded or ejected or when the tear off function is executed, the paper bail must be moved up to prevent a paper jam. Therefore, the paper bail is moved up and down by the plunger unit.

Figure 2-10 shows the plunger unit.

The paper bail is fixed to the end of the plunger iron core. The ends of the paper bail axis are connected to the left and right frames. When the plunger coil is energized, the iron core is attracted by the coil magnetism, and the paper bail is opened. When the coil is deenergized, the paper bail returns to its original position due to the paper bail spring.

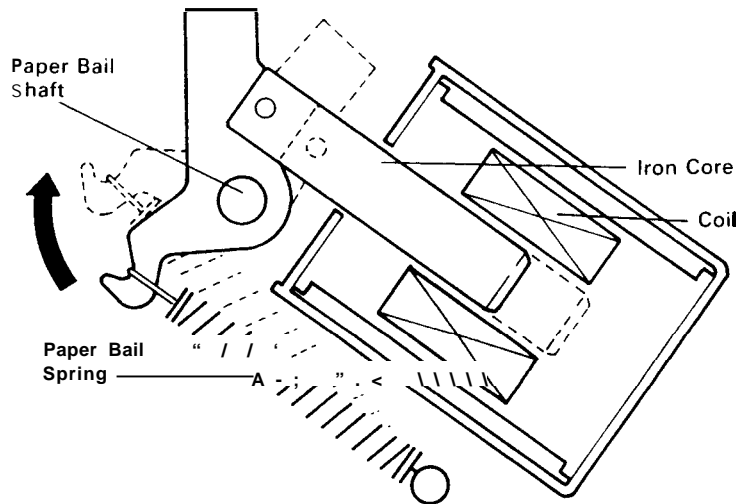

Figure 2-10. Plunger Mechanism

Table 2-9. Plunger Specifications

Type	DC solenoid
Supply voltage	36.5 ± 1 VDC
Winding resistance	12.5 ohms ±5%

● **Tractor select mechanism**

The printer mechanism has two paper entrances: the front and rear tractors.

The tractor select mechanism selects to which tractor the rotation of the paper feed motor is transmitted via the gear train, by controlling the ribbon feed motor.

Figure 2-10 shows the tractor select mechanism operation.

The ribbon motor rotates the tractor select cam clockwise through the ribbon feed select gear and tractor select transmission gear. The tractor select lever contacts the inside curve of the cam due to the spring force.

Therefore, when the cam rotates, the tractor select lever moves along the curve and sets the tractor select gear to the left or right. When the tractor select lever is set to the left, the tractor select gear engages the rear tractor train so that the rotation of the paper feed motor is transmitted to the rear tractor.

When the tractor select lever is set to the right, the tractor select gear engages the front tractor train so that the rotation of the paper feed motor is transmitted to the front tractor.

The tractor select sensor contacts the cam. The sensor switch is opened when the sensor contacts the concave portion at the bottom of the cam and is closed when the sensor contacts the convex portion.

The ribbon motor supplies mechanical power to both the ribbon feed and tractor select mechanisms. As the ribbon motor pinion rotates, the ribbon feed select gear swings like a pendulum using the lever axis as a fulcrum, and the rotation of the motor is transmitted to one mechanism or the other when the gears are engaged. When the ribbon motor rotates counterclockwise, the rotation of the motor is transmitted to the ribbon feed mechanism, and when it rotates clockwise, it is transmitted to the tractor select mechanism.

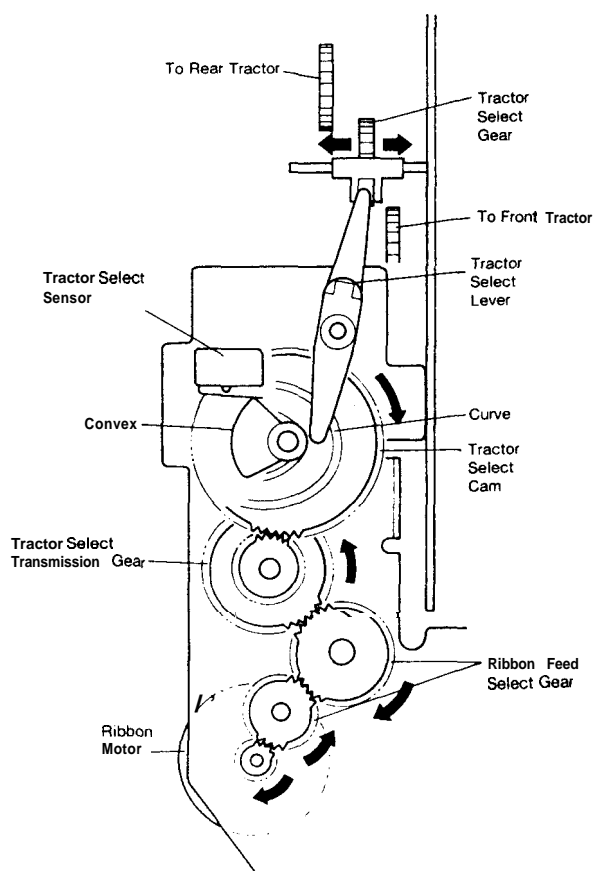

Table 2-10. Tractor Select Sensor Specifications

Type	Micro switch
Supply voltage	5 VDC + 5 %
Switch modes	Front - Open (OFF) Rear - Close (ON)

Figure 2-11 Tractor Select Mechanism Operation

2.1.6 Paper Width Detection Mechanism

The paper width detection mechanism is composed of a paper width sensor, ribbon mask, and carriage (Refer to Section 2.1.1 or 2).

The paper width sensor is attached at the right of the ribbon mask. Since the sensor position must be precise, the ribbon mask and the paper width sensor are integrated into a unit.

The sensor is a photo reflector, which moves horizontally from the 0th to 136th columns while detecting whether the paper exists or not as the carriage moves.

The detection is performed as described below each time paper is loaded.

**First pass:** Executes a carriage seek without paper loaded, and detects and stores the signal level at that time.

**Second pass:** After the paper is loaded, executes the carriage seek in the same way as the first pass, and detects the signal level difference between the portions with and without the paper.

The position at which the signal level difference is detected is the right edge of the paper, which is then used to define the printing area.

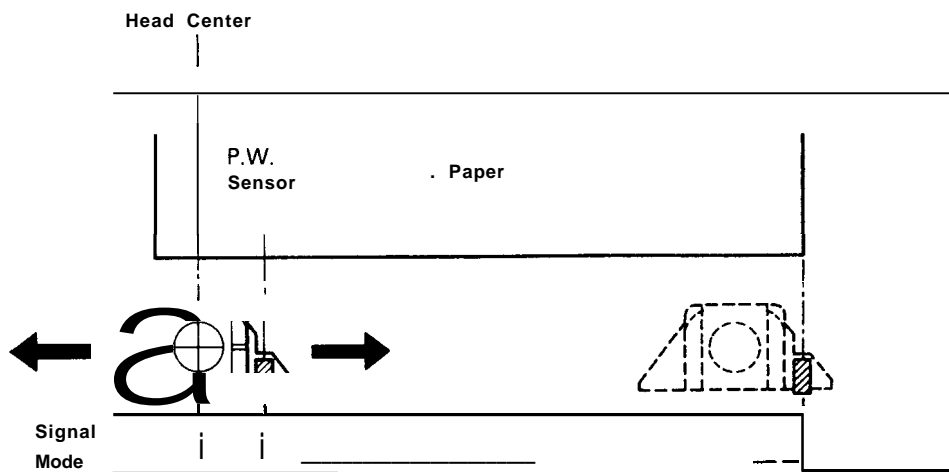

Figure 2-12. Paper Width Detection Mechanism

Table 2-11. Paper Width Detector Specifications

Type	Photo reflector
Supply voltage	5 VDC $\pm$ 5%
Output Type	Emitter follower
Output mode (paper detection)	With reflection : HIGH ( $\pm$ 5 V) Without reflection : LOW (GND)

## 2.2 POWER SUPPLY CIRCUIT

NOTE: From here on, the printer operation will be described in accordance with the corresponding circuit block diagram, operating principle figure, and circuit diagram in the APPENDIX. Therefore, read the description while referring to the corresponding circuit diagram. When part names or addresses which are not listed in the corresponding block diagram or operating principle figure are mentioned, they are listed in the circuit diagrams in the APPENDIX.

The power supply section of this printer is composed of a power switch, AC inlet, and switching power supply board . The power supply section supplies the voltages required to control the printer and drive the mechanisms. Table 2-12 shows the power specifications.

Table 2-12. Power Specifications

Name	Input Voltage	Primary Fuse Rating
BOPS	100 - 10%	125V, 8A
A	220 - 10% to 240 + 10%	250V, T6.3A



**REV.-A**

**2.2.1 DC Voltages and Applications**

Table 2-13 lists the applications of the DC voltages required by this printer.

Table 2-13. DC Voltages

Voltage	Rated Current	Application
+ 35V (vPI)	1.5A	Printer mechanism voltage ● Printhead drive
+ 35V (VP2)	1.5A	Printer mechanism voltage ● Printhead drive
+ 35V (VP3)	1.5A	Printer mechanism voltage ● Plunger ● Printhead fan ● Carriage motor ● Paper feed motor ● Platen gap motor ● Ribbon feed motor
+ 35V	—	Power supply board cooling fan
+ 5V	2A	Printer mechanism voltage ● Plunger holding ● Platen gap motor holding ● Carriage motor encoder power ● Sensor Main board control circuit voltage Reset voltage (VX) Control panel circuit voltage Cover open sensor power
+ 12V	—	Main board voltage (serial interface level conversion)
- 12V	—	Optional interface voltage supply

This printer has the following functions to help cope with abnormal operation:

- Monitors the head drive circuit on the VP 1 (+35 VDC) line, and cuts the voltage if an abnormality is detected.
- Interlock for the VP3 (+35 VDC) carriage motor common line
- Monitors the VP3 (+35 VDC) line, and cuts the voltage if any voltage fluctuation is detected.

## 2.2.2 Power Supply Circuit Operation

Figure 2-13 shows a block diagram of the power supply circuit.

The basic constructions of the BOPS and BOPSE units are the same. The figures in parentheses are the current or voltage value, and the lower portions of the rectangles indicate the locations of major elements.

The AC voltage is input to the AC inlet, and is supplied to the power supply board via the POWER switch and fuse. The AC voltage is rectified in the voltage doubler rectifier, (CHECK! full-wave rectifier), then smoothed by DB 1.

The surge-suppression circuit suppresses the surge current that flows when the printer power is turned on.

The DC voltage is divided into two lines; +35 V and + 5 V, and is converted into the DC voltages required to operate the printer by the RCC switching regulator circuits.

### ● +35 V line

The +35 V line performs DC to DC conversion via T1 and DT1.

The current limiter monitors the current input to . . . (total of . . . to . . . each current is 4A), and feeds it back to error amplifier 1 . . . in . . . 1. The constant voltage controller monitors the voltages input to . . . and VR 1 (for setting the +35 V line voltage), and feeds it back to . . . 1 (EA1).

. . . 1 turns the primary switching transistors . . . and . . . on and off using the internal transistors and . . . via transformers T2 and T3.

ri: 1 is also equipped with a dead time controller ie buf The entire switching operation can be turned off by setting the dead time to fer. an

In this circuit, four feedback paths can be used for the ino t

One is the feedback from the limiter for each output current from rom to he pi which activates the r-- if an over current is output from the driver circuit.

The current limiter mentioned above is used to recover this limiter.

The second is the feedback from the current limiter.

The third is the feedback from the power down signal on the main board. If an error occurs and it is necessary to cut the voltage to prevent the printer from being damaged, the is activated by the PD signal.

The forth is the feedback from the ground level monitor, which activates the | and cuts the voltage to prevent the printer from operating abnormally if the potential difference between the ground (G ND) levels of the +35 V and +5 V lines cause a current of 1A to flow.

### ● +5 V line

The +5 V line performs DC-DC conversion via T4 and DT2.

The current limiter monitors the current flow to R66 and feeds it back to | (comparator).

: INI turns the primary switching transistor -L- on and off via photo coupler PC2.

The constant voltage controller | (shunt regulator) feeds back the voltage fluctuation to |

The V line is also output in parallel from the + 5 V line. When the +5 V line becomes stable, the 12 V line also becomes stable. In this circuit, fuse resistors R7 1 and R72 work as a current limiter.

REV.-A

● CL signal

The constant voltage controller on the 35 V line not only monitors the voltage input to R34 and VR1 (for setting the 35 V line voltage) and feeds it back to IC1 (EA1), but also controls output of the CL signal which informs the CPU on the main board that voltage limiting has occurred for the 35 V line. If limiting is executed for the constant voltage controller, (which means the circuit enters the overload state,) comparator IC5A detects it and generates the CL signal.

Upon receiving the CL signal, the CPU on the main board is interrupted, and executes the recovery sequence for the power supply overload state. (Refer to Section 2.3.5.)

● SO signal

The voltage status at the primary side is also monitored by the primary voltage monitor. This is used to generate the switch off (SO) signal which tells whether the printer power is on or off. If the output voltage at the stage just after rectifying and smoothing on the primary side drops to 170 V or less, shunt regulator Q3 detects it and causes the SO signal generator to generate the SO signal via photo coupler PC 1. The SO signal causes a non-maskable interrupt to the CPU on the main board, so that it can write (back up) the data which must be stored in non-volatile memory when the printer power is turned off. (For details, refer to Section 2.3.3.)

The power supply unit has a cooling fan which is driven by the +35 VDC to cool the elements on the circuit board. Since the fan is placed below the carriage motor, it also cools the carriage motor.

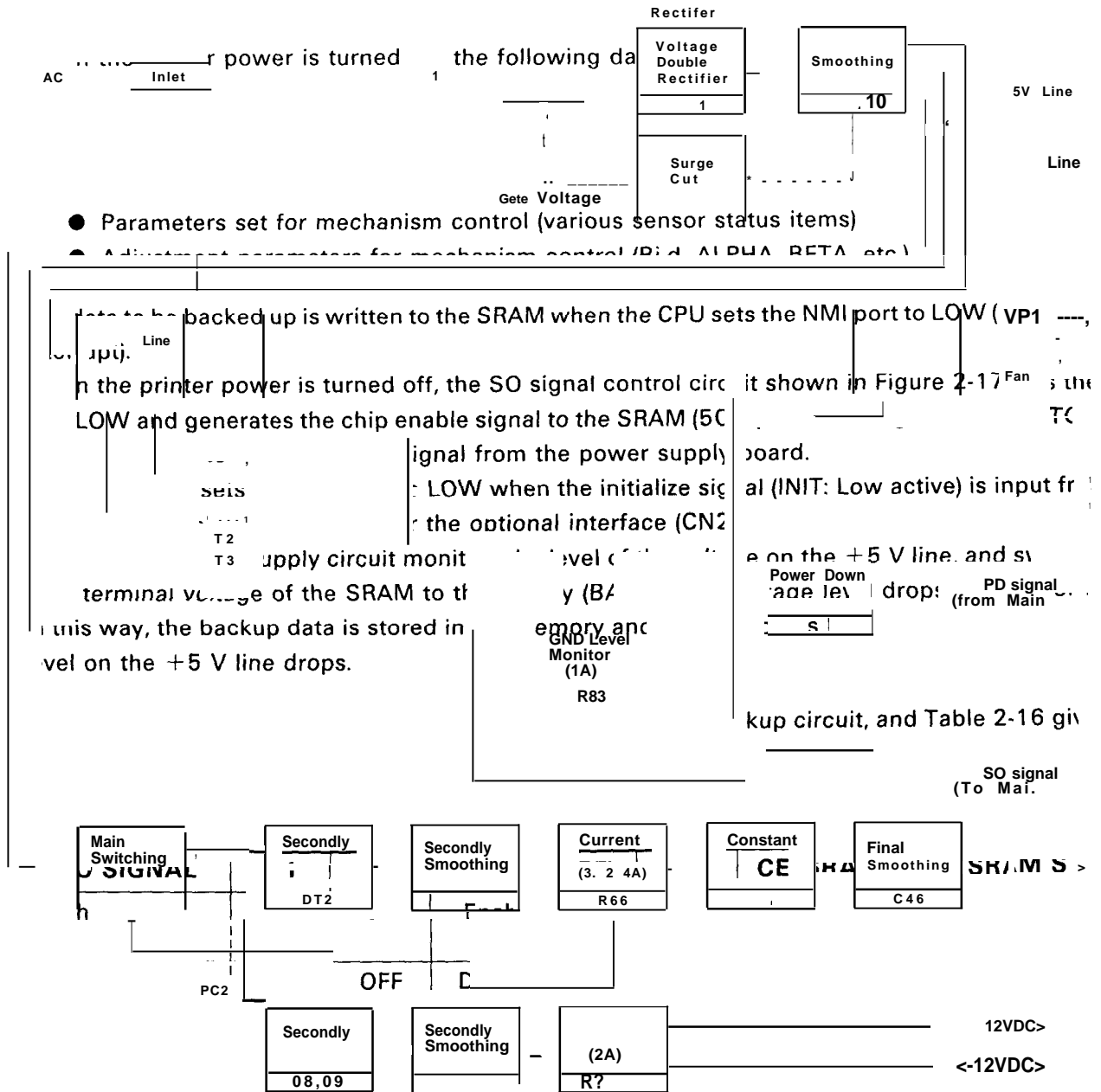

Figure 2-13. Power Supply Section Block Diagram

## 2.3 CONTROL CIRCUIT

Figure 2-14 shows a block diagram of the control circuit, with the main board at the center. The printer employs a  $\mu$ PD78322 internal 16-bit processing/external 8-bit bus one-chip CPU (5E) as the main CPU. This CPU is driven with a 14.7 MHz external clock (CR2).

The control program is stored in the internal mask ROM (5E: mainly for mechanism control) and external PROM 27 (3B: mainly for ESC/P and IBM emulation, interfacing, and CG). The CPU starts executing the program upon receiving the reset signal from an external device.

The internal RAM and the external PSRAM HM6264 are used for memory space. Also, the non-volatile memory circuit is used to store the operating parameters set using the control panel, such as the TEAR OFF position, and the factory adjustment parameters, while the printer power is turned off.

Two gate arrays, E05A38NA (6A) and E05A16GA (2E) are used to allocate the memories and I/O area, in order to simplify the circuit. Both gate arrays are controlled by the CPU via the address bus using MMIO (Memory Mapped I/O).

The functions of the primary ICs are as follows:

- Main CPU  $\mu$ PD70322 (5E)

The  $\mu$ PD70322 is the main CPU in the control circuit. It receives parallel data via gate array E05A38NA (6A) or directly receives serial data (from the host computer) and stores the data in an input buffer in the SRAM (3 B).

When the printing start interrupt routine (the CPU receives the CR code or the input buffer becomes full) is started, the CPU expands the data in the input buffer to the image buffer by accessing the character generator (CG). Then it transfers the image data to the E05A38NA (6A) and sets the head data.

During printing, the CPU outputs the FIRE signal from the internal timer to control print timing. The MMU (Memory Management Unit) in the CPU controls the memories via external devices such as the slave CPU (E05A38NA in this printer).

An internal 8-channel 8-bit A-D converter is used for checking the status of each sensor in the mechanisms, the panel/DIP switch status, and the power supply voltage.

Upon receiving a signal indicating a problem (SO or CL), or the ON LINE signal, the CPU executes physical interrupt processing using the interrupt port.

- Gate Array E05A38NA (6A)

The E05A38NA is a custom gate array containing the following functions in a single chip.

- Address decoder: Generates the chip select signal.
- Address latching: Latches and outputs the lower address.
- Print data generation: Controls dividing of the data into two halves (for each row of the printhead)
- DC motor driver: Controls the carriage motor.  
Controls the printhead cooling fan.
- Pulse counter: Counts pulses from the carriage motor encoder.
- Interface controller: Controls the parallel interface.

The E05A38NA is controlled by the CPU using  ports. The address timing is controlled by connecting the ASTB (Address Latch Strobe) pulse from the CPU to the ALE (Address Latch Enable) terminal.

Although the data read/write timing is controlled by  commands from the CPU, the gate array directly controls the printer mechanism and interface once the parameters are set. In particular, the DC motor control section separately controls the printing operation (driving and stopping the motor) using an external oscillator circuit exclusive for this gate array, unless the printing mode is not changed. The status of the internal registers and ports are initialized upon receiving the reset signal.

#### ● Gate Array E05A16GA (2E)

The E05A16GA is a one-chip gate array common to the  containing the following functions:

- Super/subscript generator: Converts normal character generator  patterns (image data) into super/subscript character data, and outputs it.
- Italic character generator: Converts normal CG patterns (image data) into italic character data and outputs it.
- Reset signal generator: Takes the logical sum of the external reset signals from two lines and outputs it to the external devices.
- Output port with various output formats for different applications: CR motor control circuit, plunger drive circuit, control panel lamp control circuit, DIP switch status read circuit drive signals, and  motor drive signals.
- General-purpose input port: GAP/TRCT/cutter (optional) sensor signal, status of the parallel interface, control panel switch status, PD (Power Down power supply board) signal
- 8-bit parallel interface control: Inputs the PE and ERROR signals.
- Serial interface control: When using the serial interface, this chip multiplexes the two receive data lines (RXD and bit 7 of the 8-bit parallel interface) using internal logic, and outputs the result to an external device.

The E05A 16GA is controlled by the CPU via MM IO. Addressing is performed using the lower three bits (AO to AZ) of the address bus.

The internal registers and ports are initialized upon receiving the reset signal.

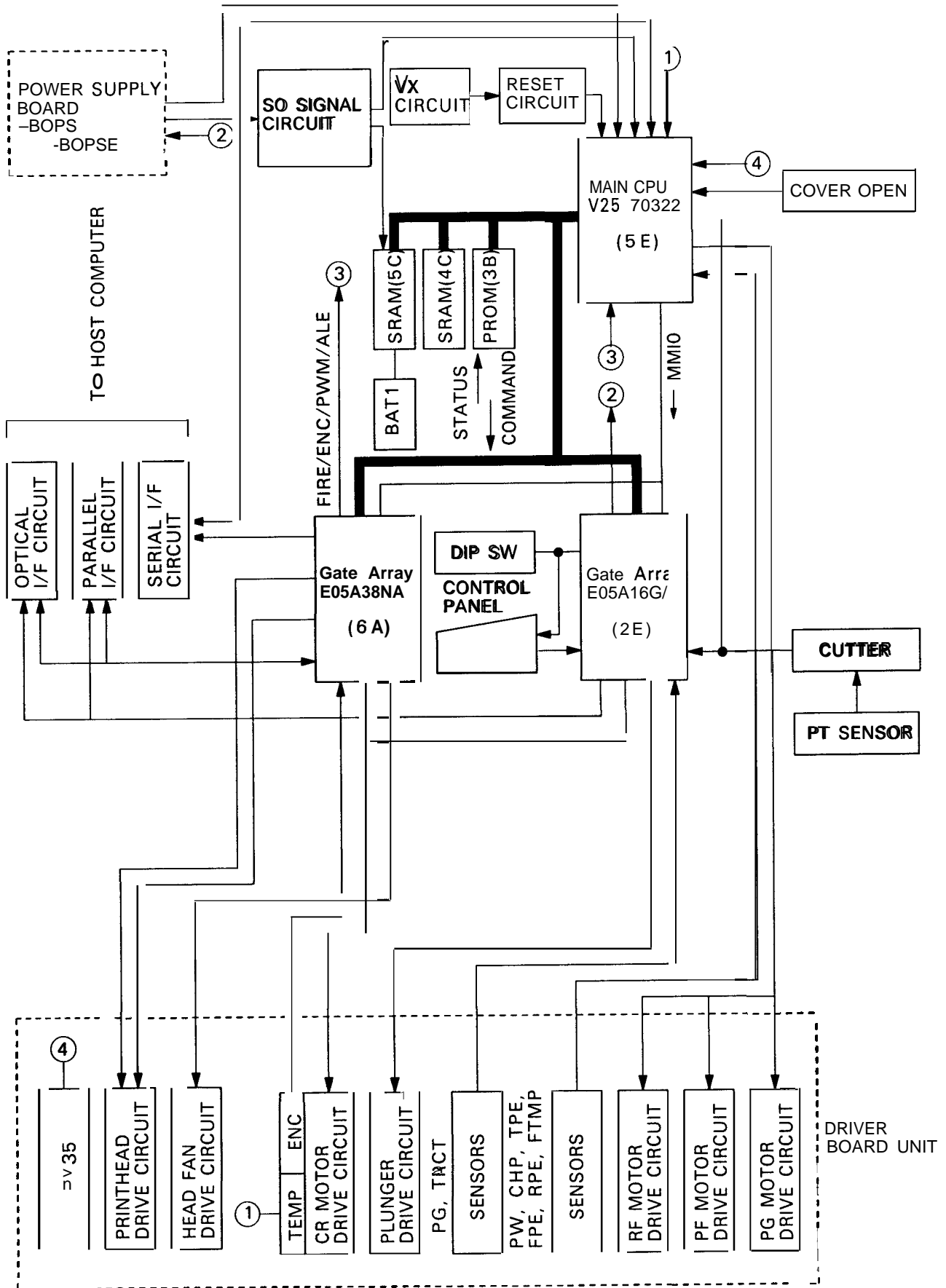

Figure 2-14. Control Circuit Block Diagram

### 2.3.1 Interface Circuit

Figure 2-15 shows a block diagram of the interface circuit.

This section describes the data flow when data is input or output via each interface.

#### ● Parallel interface

When the E05A38NA gate array latches the data from the host computer (upon receiving the STRB signal), it automatically outputs the BUSY signal. The CPU reads the software BUSY status by reading an MMIO port, and stores the data in the input buffer. After the CPU checks the data, it causes the E05A38NA to clear the BUSY signal and output the ACK signal to the host computer.

#### ● Serial interface

The receive data RXD (RECEIVE DATA) from the host computer and the bit 7 data from the 8-bit parallel interface (when optional serial interface #8 143 is used) are multiplexed using the internal logic of the E05A16GA gate array, and is output to the CPU asynchronous serial communication interface (ASCI).

The data is transferred from the CPU to the input buffer.

The transmit data TXD (TRANSMIT DATA) is output directly from the ASCI in the CPU.

In the case of the DC 1/DC3 protocol, the DC3 code is output when the buffer becomes full. (The DC 1 code is output when the buffer is ready for more data.)

The REV signal (same as DTR: DATA TERMINAL READY) is output on the same line as the parallel interface BUSY signal, and performs DTR control. Therefore, the parallel and serial interfaces cannot be used at the same time.

Printing is started when the CR code is input or the buffer becomes full. The data in the input buffer is expanded into the line edit buffer, and the image data referenced by each parameter of the line edit buffer is expanded into the image buffer (by accessing the CG). The expanded image data is transferred to the E05A38NA gate array in units of 8 bits, and becomes the print data.

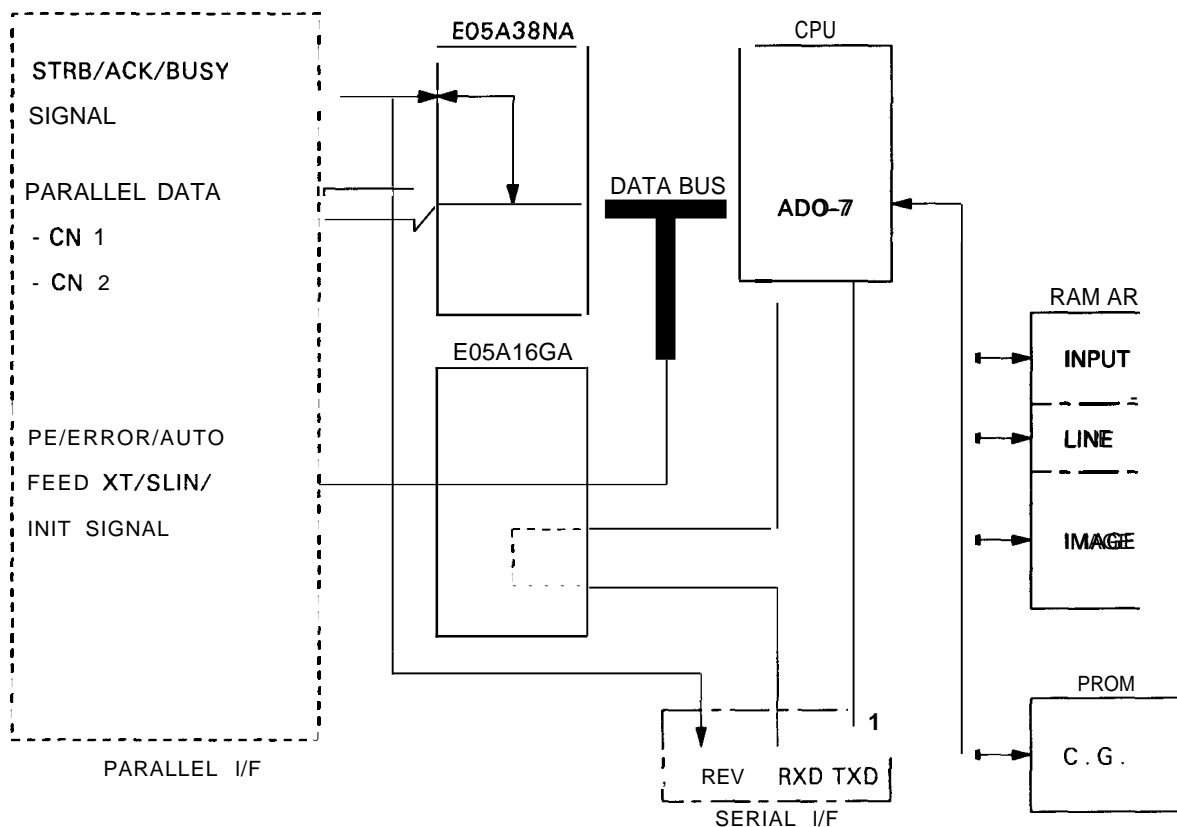

Figure 2-15. Interface Circuit **Block Diagram**



2.3.2 Reset Circuit

Figure 2-16 shows a block diagram of the reset circuit.

The Vx circuit is the power-on reset circuit which generates the reset signal when the voltage becomes unstable due to the printer power being turned on or off. The reset signal is input to the E05A1 6GA gate array via the CPU, amplified, then supplied to the E05A38NA gate array and optional interface to reset each IC.

The circuit monitors the + 12 V line using Zener diode ZD2, and the threshold voltage level is 4 V. Transistor Q2 is turned on or off by ZD2.

Table 2-14. Power-On Reset Status

+12 VDC Line Level	Q2 Status	Vx output	RESET signal
< 4 VDC	OFF	GND (0V)	Low
4 VDC <	ON	+5V	High

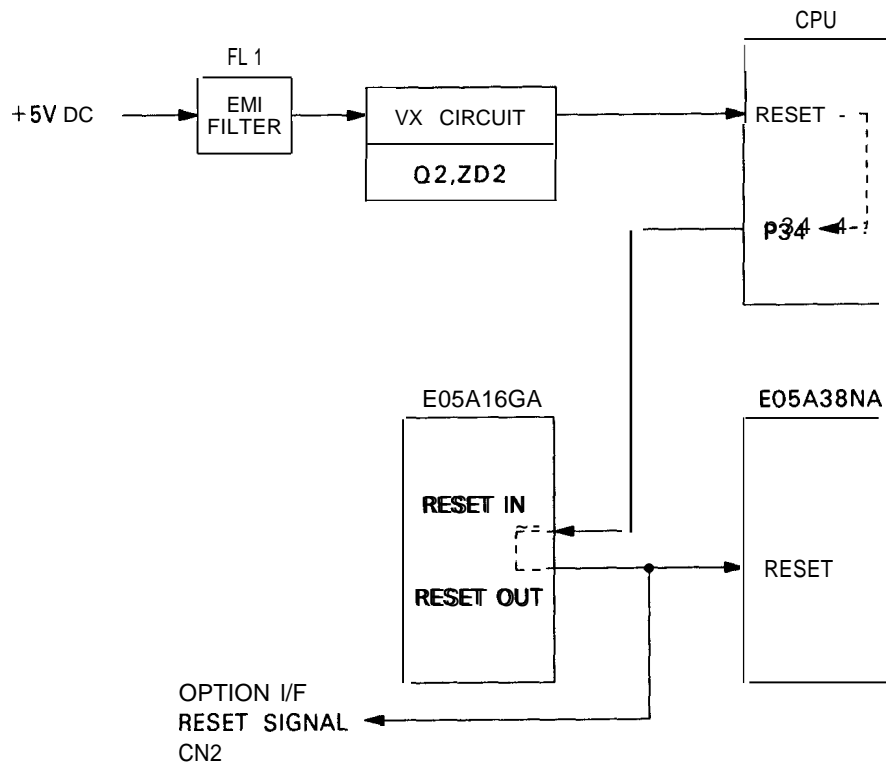

Figure 2-16. Reset Circuit Block Diagram

### 2.3.3 Memory Backup Circuit

Figure 2-17 shows a block diagram of the reset circuit.

When the printer power is turned off, the following data is backed up in the SRAM (5 C).

- Settings for paper handling, which are set using the operator panel, such as TOF, TEAR OFF, and PAPER MEMORY functions.
- USER DEFINED CHARACTERS
- Parameters set for mechanism control (various sensor status items)
- Adjustment parameters for mechanism control (Bi-d, ALPHA, BETA, etc.)

The data to be backed up is written to the SRAM when the CPU sets the NMI port to LOW (non-maskable interrupt).

When the printer power is turned off, the SO signal control circuit shown in Figure 2-17 sets the NMI port LOW and generates the chip enable signal to the SRAM(5C) upon receiving the SO (SWITCH OFF: Low level, refer to Section 2.2.2) signal from the power supply board.

The circuit also sets the NMI port to LOW when the initialize signal (INIT: Low active) is input from the standard parallel interface (CN 1 ) or the optional interface (CN2).

The backup voltage supply circuit monitors the level of the voltage on the + 5 V line, and switches the VDD terminal voltage of the SRAM to the battery (BAT 1 ) if the voltage level drops to 4.2 V or less. In this way, the backup data is stored in the memory and the memory is backed up before the voltage level on the +5 V line drops.

Table 2-15 lists the operation of each element in the memory backup circuit, and Table 2-16 gives the battery specifications.

Table 2-15. Operation of Each Element in the Memory Backup Circuit

SO SIGNAL	Q1	Q8	NMI (CPU:5E)	al o	CE (SRAM:5C)	SRAM Status
High	ON	ON	Enable (Low)	ON	Enable (High)	Writes data. - Backup
Low	OFF	OFF	Disable (High)	OFF	Disable (Low)	No backup

Table 2-16. Battery Specifications

Nominal voltage	3 V
Operating temperature	-20 to +70°C
Safety standard	UL approved
Discharging duration	1700 to 3000 hours or more (See NOTE)

**NOTE:** The specifications above are for continuous discharging duration measured under the following conditions, which are the reference data for the life of the battery. The life varies depending on the operating environment. However, the standard life is about five years.

- Load at both ends of the battery :5.6 Kohms
- Ambient temperature :10 to 23°C
- Relative humidity :75% or less

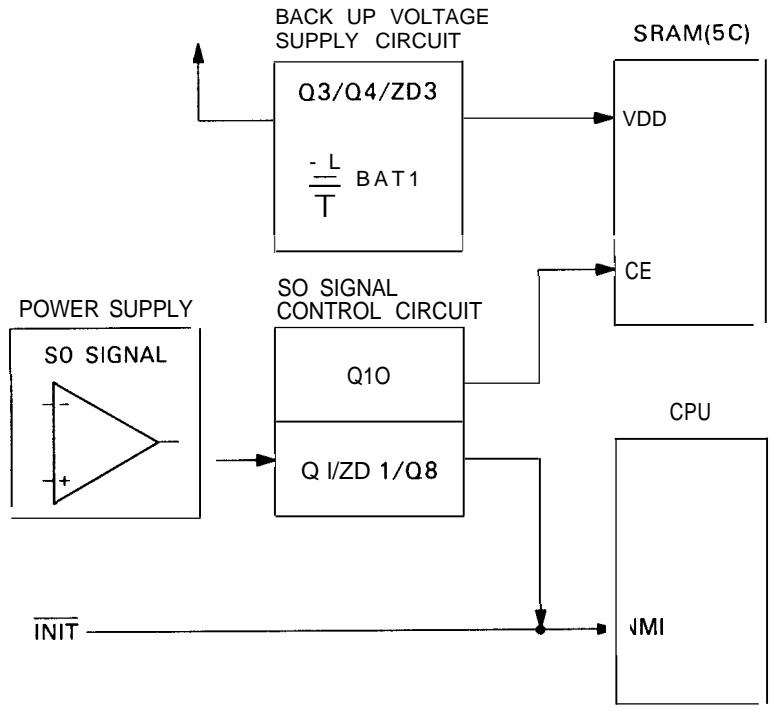

Figure 2-17. Memory Backup Circuit Block Diagram

### 2.3.4 A-D Converter Detection Circuit

Figure 2-18 shows a block diagram of the A-D converter detection circuit.

The CPU includes an 8-channel 8-bit A-D converter. Each detection terminal is used to detect signals which continually change, making the best use of the A-D converter.

Table 2-17. A-D Converter Port Functions

Port	Signal Name	Function	Operation
AN0	DV35	Detects the fluctuation (32 to 38 VDC) of the driver circuit voltage (VP3).	Determines when the voltage is abnormal (rings the buzzer).
AN1	H.TMP	Detects head coil overheating (120°C).	Stops printing until the head coil temperature drops (the printhead moves to the home position and is cooled by the external fan).
AN2	F.TMP	Detects head cooling fan overheating.	Stops the fan until the fan temperature drops.
AN3	MTR TMP	Detects carriage motor overheating.	Stops the motor until the temperature drops.
AN4	P.WID	Converts the paper width detector output level.	Detects the paper width.
AN5	DIPSW 3	Reads the DIP switch settings.	Reads the DIP switch settings when the printer is reset.
AN6	DIPSW 2		
AN7	DIPSW 1		

REV.-A

The settings of DIP switches 1 to 3 are read by switching the time-sharing circuit.

The CPU writes the data to the PB ports of the E05A 16GA gate array so that only the port connected to the DIP switch the CPU wants to read goes LOW. the PB ports of the E05A 16GA gate array are normally used to drive the lamps on the control panel (except when the printer is reset).

To read a certain DIP switch, the data which makes only the port connected to the DIP switch go LOW is written to the E05A1 6GA.

Since the A-D terminal, the DIP switch, and port PB of IC3C (grounded) become a closed circuit, DIP switch reading is enabled. This read operation is performed eight times per DIP switch and three times per A-D terminal.

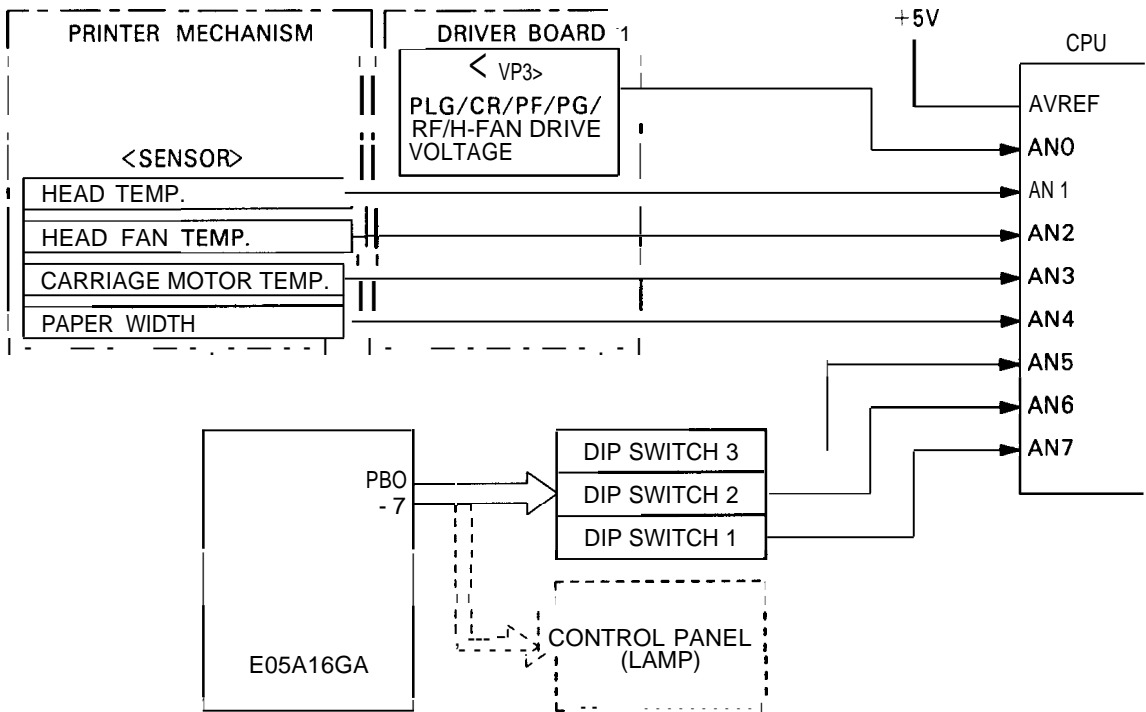

Figure 2-18. A-D Converter Detection Circuit

2.3.5 Interrupt Port Detection Circuit

Figure 2-19 shows the interrupt detection signal assignment block diagram for the CPU. The CPU includes an interrupt controller, and executes forced interrupt operation in accordance with the priority of the interrupt.

Table 2-18. Interrupt Port Detection Signal Functions

Port	Signal	Function	Operation
NMI	so	Detects voltage drop at the primary power supply (power off)	Backs up the memory (refer to Section 2.3.3).
INT0	ON LINE	Detects the ON LINE switch.	Switches between ON LINE and OFF LINE.
INT1	ENCAB	Detects the carriage motor encoder output bypass signal (E05A38NA).	Starts interrupt operation for carriage motor position/speed control.
INT2	CL	Detects power supply overload.	Reduce the printing speed (see NOTE).
INT5	COVER SW	Detects the cover open sensor status.	Sets the printer OFF LINE when top cover open is detected.

NOTE: CL is detected for each line. If an overload is detected, printing speed is lowered to one third of normal.

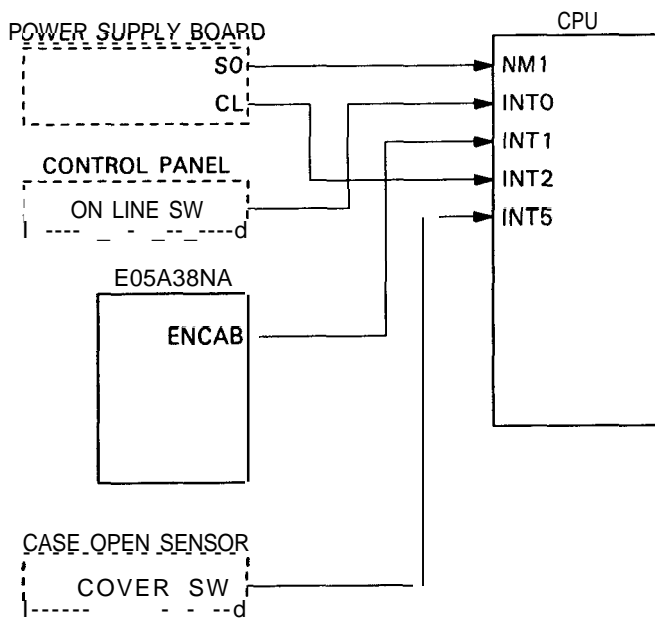

Figure 2-19. CPU Interrupt Port Detection Signal Assignment

2.3.6 Detection Circuits Connected to the General-purpose Ports

Figure 2-20 shows a block diagram of the general-purpose ports assigned to detect signals.

As shown below, sensor signals from the various mechanisms are assigned to the general-purpose ports of the CPU and the E05A 16GA. The data latched at the general-purpose ports of the E05A 16GA is transferred to the CPU.

Some of the signals from the mechanisms are input to the main board via the driver board.

Table 2-19. General-purpose Ports Assigned to Detect Circuit Signals

	Port	Signal Name	Function	Operation
E o 5 A 1 6 G A	IN6	CUT.HP	Detects the cutter home position signal when the optional cutter unit is mounted.	Controls the optional cutter.
		P.TRCT	Detects the optional tractor unit.	Controls the optional tractor unit.
	IN5	CUTTER	Detects the optional cutter unit installation.	Controls the optional cutter.
	PAO	TRCT. SEL	Detects which is selected, the front or rear tractor.	Controls paper feeding (for confirming the front/rear paper switching mechanism; Paper feed error warning).
	IN4	GAP A	Detects the platen gap sensor signal.	Controls the PG mechanism (controls the PG measure and PG setup operations by detecting the amount of the PG motor rotation).
	IN3	GAP B		
c P u	P07	HNERR	Detects a defective driver board head driver IC. (NPN transistor array)	Indicates a head drive error.
	P06	HPERR		
	P24	CR.HP.	Detects the carriage home position sensor signal.	Controls the carriage position. Indicates a carriage error.
	P25	T.PE	Detects the top paper end sensor signal.	Controls paper feeding (for confirming the paper load/eject operation and front/rear paper switch operation; Paper feed error warning).
	P26	F.PE	Detects the front paper end sensor signal.	
	P33	R.PE	Detects the rear paper end sensor signal.	

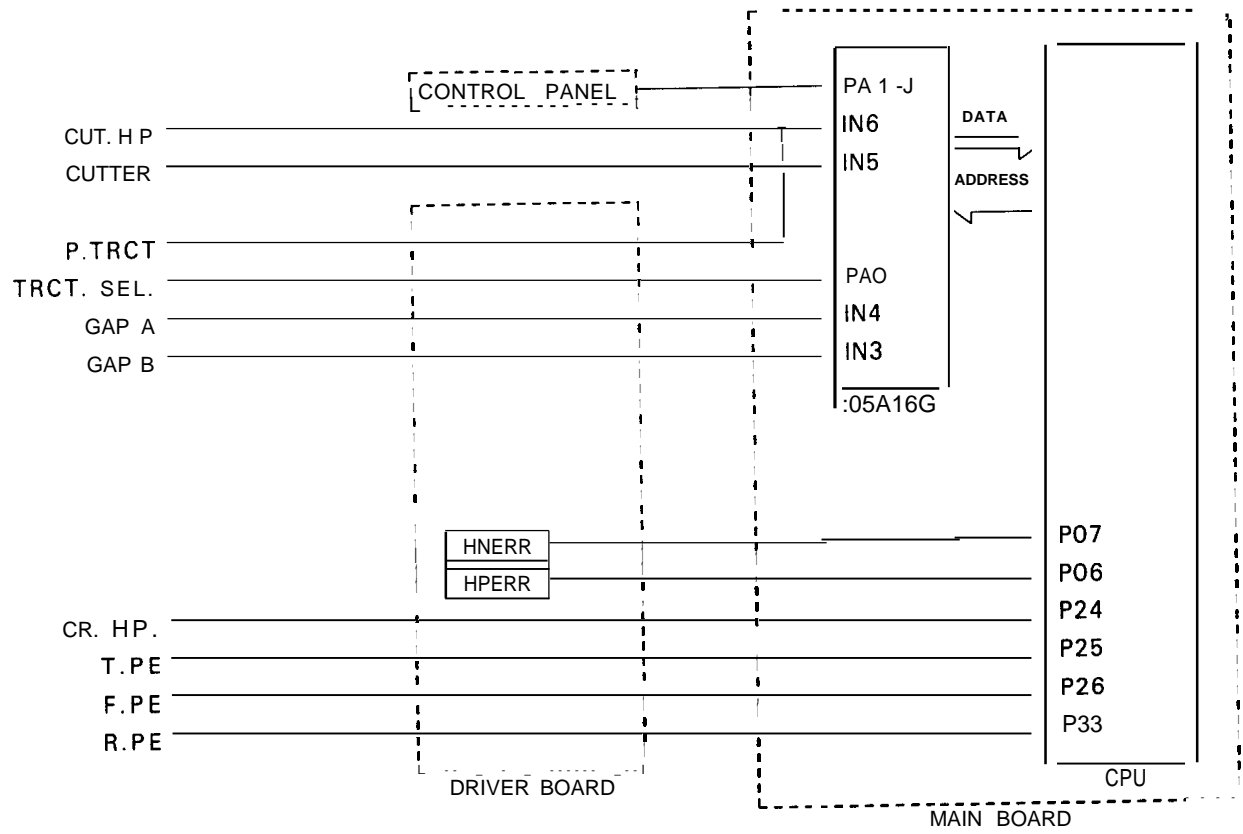

Figure 2-20. General-purpose Ports Assigned to Detect Signals



2.3.7 Ribbon Feed Motor/External Fan Control/Drive Circuit

Figure 2-21 shows a block diagram of the ribbon feed motor control/drive circuit.

The ribbon feed motor is a PM type pulse motor driven with 2-2 phase excitation, which can be driven in either the forward or reverse direction and stopped at any position. The phase signals output from two pins are expanded by the predrive circuit, output from four pins, and transmitted to the driver board. The hold/run signal (RF H/R, which is the common voltage RFCOM switching signal) is output from the E05A16GA.

The drive voltage is a constant 36.5 VDC from the VP3 line.

The common line for the ribbon feed motor is connected to the external fan drive line. Therefore, the external fan always operates when the ribbon motor operates.

Table 2-20 shows the circuit specifications.

Table 2-20. Ribbon Feed Motor Control/Drive Circuit Specifications

	Ribbon Feed Motor	External Fan
Supply voltage	36.5 ± 1 VDC	36.5 ± 1 VDC
Current consumption	0.10 A (average)	70 mA (average)/90 mA (max.)
Drive frequency	720PPS	
Driving method	Unipolar constant voltage drive, 2-2 phase excitation	

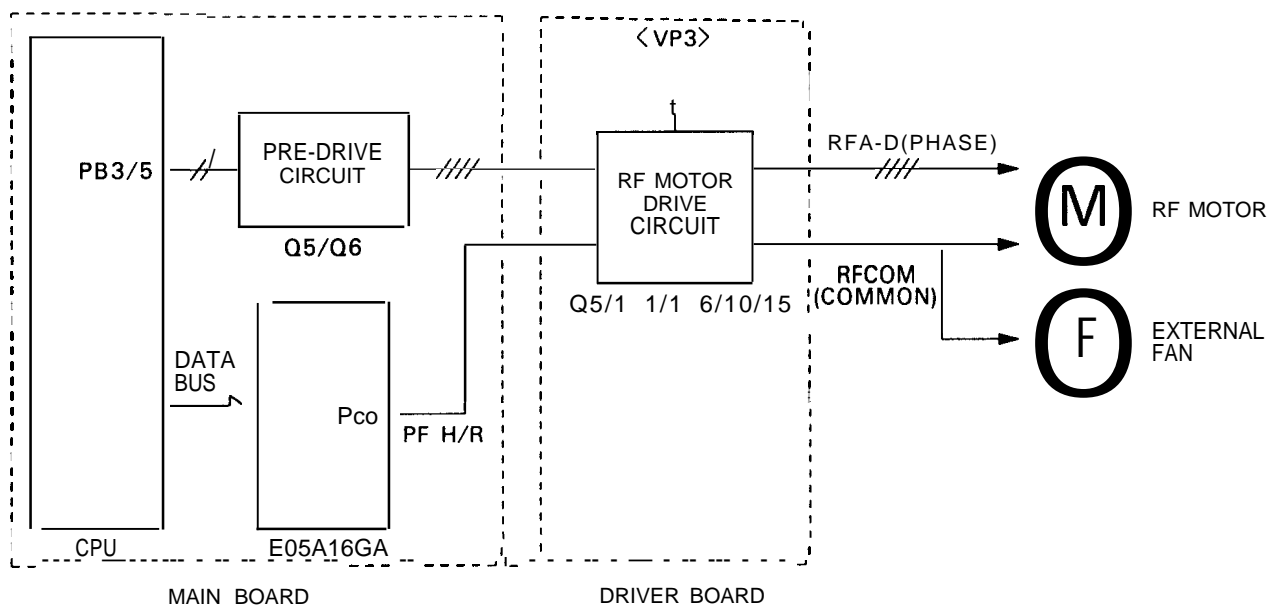

Figure 2-21. Ribbon Feed Motor Control/Drive Circuit **Block Diagram**

### 2.3.8 Paper Feed Motor Control/Drive Circuit

Figure 2-22 shows a block diagram of the paper feed motor control\ drive circuit.

The paper feed motor is an HB type pulse motor driven with 1-2 phase excitation, and can be rotated in either the forward or reverse direction and stopped at any position. The phase signals are output from four pins of the CPU to the driver board.

The paper feed motor is driven in any of the following three modes:

- Micro step mode (during forward or reverse micro adjusting)
- Middle speed mode (during forward or reverse feeding)
- High speed mode (only during forward feeding)

Switching among the above three modes is executed by changing the current applied to paper feed motor driver STK67 13B. The drive current switching signal (PF H/R, which is the common current PFCOM switching signal) is output from the E05A1 6GA. The VREF port of the STK67 13B, which sets the reference voltage for the internal chopper controller, is set to the output voltage level of the drive current select circuit. The drive current select circuit switches the output voltage level in accordance with the PF H/R signal. Table 2-21 shows the circuit specifications.

Table 2-21. Paper Feed Motor Control/Drive Circuit Specifications

Supply voltage	36.5 ± 1 VDC (voltage applied to the driver circuit)
Current consumption (per phase)	1.75 ± 0.20 A (driving, average) 0.20 ± 0.02 A (holding)
Drive frequency	2610 PPS (Middle speed mode, constant speed) 4274 PPS (High speed mode, constant speed)
Driving method	Chopper constant current drive, 1-2 phase excitation
Paper feed pitch	1/2 16" (O. 12 mm): 2 steps 1/6" (4.23 mm): 72 steps 1/8" (3. 18 mm): 54 steps 1/9" (2.82 mm): 48 steps
Paper feed speed	1.7 IPS (Micro step mode) 6.0 IPS (Middle speed mode) 9.9 IPS (High speed mode)

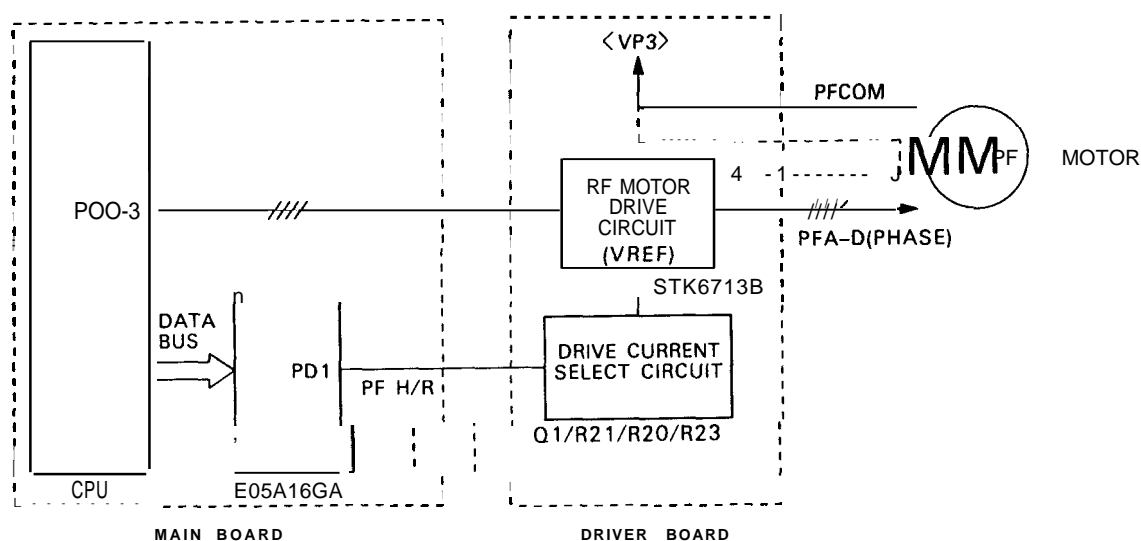

Figure 2-22. Paper Feed Motor Drive Modes

2.3.9 Platen Gap Motor Control/Drive Circuit

Figure 2-23 shows a block diagram of the PG motor control/drive circuit.

The PG motor is a PM type pulse motor driven with 2-2 phase excitation, and can be rotated in either the forward or reverse direction and stopped at any position. The phase signals output from two pins are expanded by the predrive circuit, output from four pins, then transmitted to the driver board. The hold/run signal (PG H/R, which is the common voltage PGCOM switching signal) is output from the E05AI 6GA.

The drive voltage is a constant 36.5 VDC from the VP3 line.

The PG motor is controlled in accordance with the signal from the PG sensor. The A-phase output pulse (GAPA) from the platen gap sensor is input to port IN4 of the E05A16GA.

The B-phase output pulse (GAPB) is input to IN3. The CPU counts these pulses using an internal counter, and determines the amount and direction of the motor rotation. Therefore, the distance the PG motor moves can be obtained from the PG sensor signal.

Table 2-22. PG Motor Control/Drive Circuit Specifications

<b>PG Motor</b>	
Supply voltage	36.5 ± 1 VDC (voltage applied to the driver circuit)
Current consumption (per phase)	0.2 A (driving, average) 0.02 A ± 5 mA (holding)
Drive frequency	285 PPS
Driving method	Unipolar constant voltage drive, 2-2 phase excitation
<b>PG Sensor</b>	
Supply voltage	5 VDC ± 5% (voltage applied to the driver circuit)
output	Rectangular waveform, 2 channels, TTL level

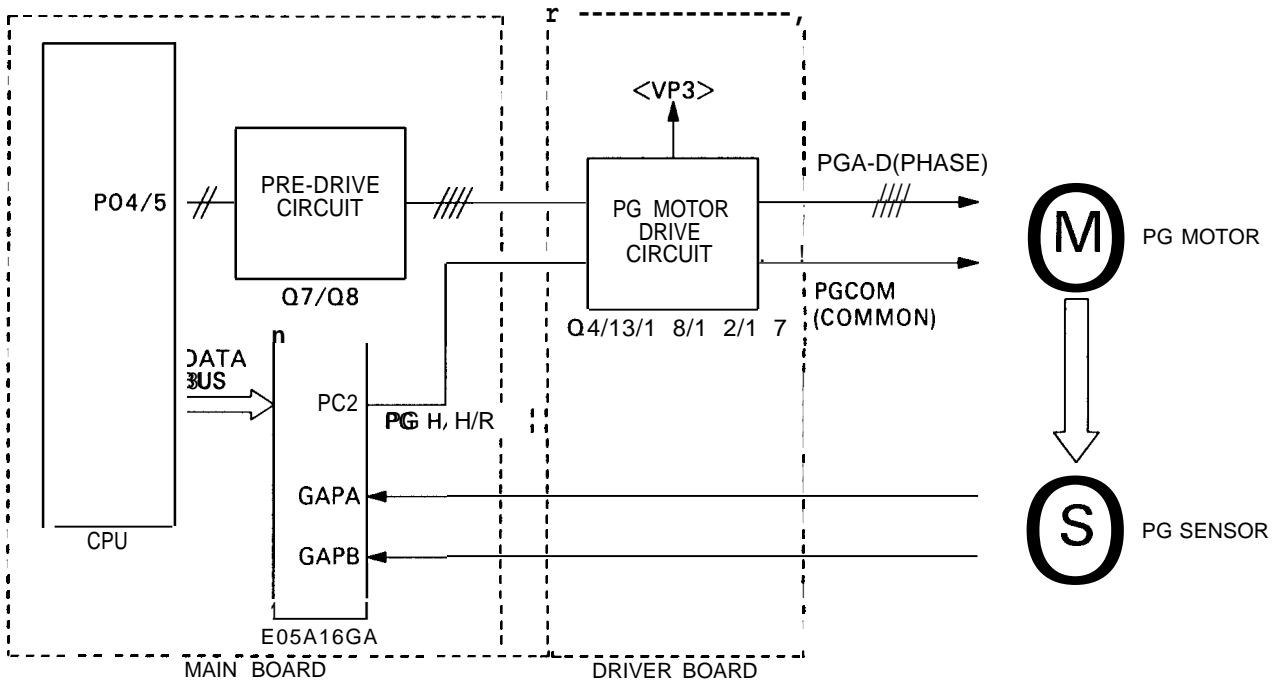

Figure 2-23. PG Motor Control/Drive Circuit Block Diagram

The platen gap is reset each time the paper is loaded. The platen gap setup sequence is shown in Figure 2-24.

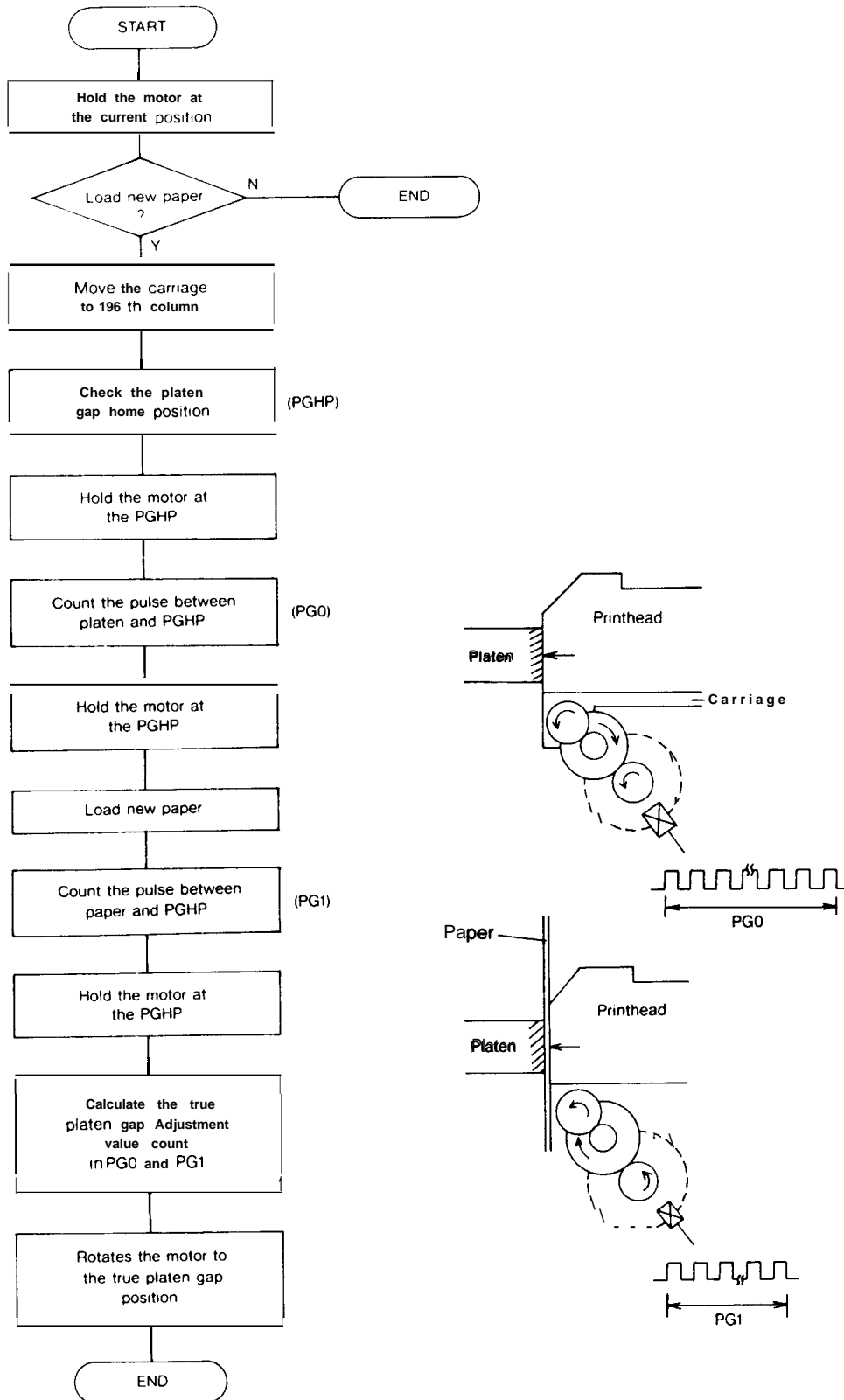

Figure 2-24. Platen Gap Setup Sequence

REV.-A

Figure 2-25 shows the platen gap setup conceptual diagram.

Symbols used in the diagram are as follows:

- PG : Gap between the printhead and platen (should be constant)
- A : Distance which varies in accordance with the difference in the printhead dimension
- B : Distance which varies in accordance with the difference in the dimension of a mechanism other than the printhead
- x : Amount of PG motor rotation equal to 70 steps (constant value)
- PGEND : Position which limits the PG motor rotation (The PG motor cannot rotate beyond this position.) (constant value)

The PG mechanism is composed of the shaft which moves the PG motor, platen, carriage, printhead, and carriage forward and backward and the gear connected to the shaft. Since the dimension of each part is different depending on the product, the PG value also varies depending on the product. Therefore, in order to make the PG value constant among all the products, the values which are not constant (A and B) are adjusted.

These values are alpha, used to adjust for the difference in printhead dimensions, and beta, used to adjust for the difference in PG mechanism dimensions. They are actually numeric data used by the software to determine the amount of PG motor rotation.

The adjustment values are written to the SRAM (5C) on the main board, which is maintained by a backup circuit when the printer power is turned off.

When the printer power is turned on, the CPU reads these values as part of the initialization sequence, and adjusts the PG.

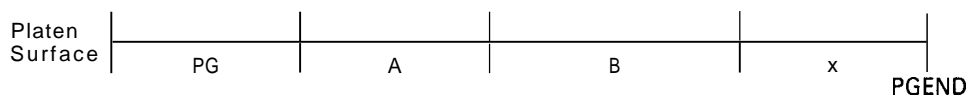

Figure 2-25. Platen Gap Setup Conceptual Diagram

### 2.3.10 Carriage Motor Control/Drive Circuit

Figure 2-26 shows a block diagram of the carriage motor control/drive circuit.

The carriage motor is a DC servo motor driven using bipolar drive, and can operate in any of the following modes.

- a. Forward rotation "RUN" mode: Driven state. The carriage moves from left to right.
- b. Forward rotation "BRAKE" mode: Non-driven state. The carriage is slowed down.
- c. Reverse rotation "RUN" mode: Driven state. The carriage moves from right to left.
- d. Reverse rotation "BRAKE" mode: Non-driven state. The carriage is slowed down.
- e. Halt mode: Driven state. The carriage is held at any position.

The phase signals (CRA to CRD) are inverted by the predrive circuit, and transmitted to the driver board. The relationship between the modes and phase signals is shown in Table 2-24.

The carriage motor speed is controlled using either PRC (Period Control) or PWM (Pulse Width Modulation) control. PRC control is used for high and middle speeds, and PWM control is used for middle and low speeds. The PRC/PWM switching signal is output from port P32 of the CPU to port PWM of the E05A38NA, and the E05A38NA changes the control sequence.

Torque switching corresponding to the rotational speed is executed by changing the current applied to motor driver STK6885H, which is the same principle used for the paper feed motor speed control. The drive current switching signals (CRI 1 to CRI3) are output from the E05A16GA.

The VREF port of the STK6885H, which sets the reference voltage of the internal chopper controller, is set to the output voltage level of the drive current select circuit. The drive current select circuit switches the output voltage in accordance with the drive current switching signal (CRI 1, CRI2, or CRI3). The drive voltage is a constant 36.5 VDC from the VP3 line. An interlock mechanism is installed in the motor common line, so that the drive current is cut when the case is open.

Carriage motor control is performed using the carriage home position sensor (CHP sensor) and the encoder signal. The CHP sensor determines the reference position for carriage operation during initialization (home position seek) when the printer is reset. If the CRHP signal is not detected during home position seeking, it is regarded as a carriage error.

The encoder signal is input to the ENC port of the E05A38NA, and feeds back the following:

- Number of pulses counted, which is the distance the carriage has moved
- Interval between the pulse edges, which is the speed of the carriage
- Pulse edge of the detected A-/B-phase, which is the direction the carriage is moving

When the encoder signal is input to the ENC port of the E05A38NA, the encoder pulse interval is output as is from the EN CAB port to the CPU. The CPU generates the print timing upon receiving the signal at the INT 1 port.

Since the encoder signal must be output continuously while the motor is operating, it is regarded as a carriage error if the signal is not detected. Since the home position is outside the 20-printable area, it is also a carriage error if the CRHP signal is detected during printing.

REV.-A

The carriage contains a thermistor. An A-D converter in the CPU detects the motor temperature (MTR TMP) each time printing for one line is completed. If the temperature rises above the limit, a motor problem is recognized, and the following lines will be printed at one-step lower speed.

In the case of this printer, printing is possible during acceleration/deceleration of the motor to improve the throughput. However, misalignment occurs in the bidirectional printing mode because of the deflection of the timing belt during acceleration/deceleration and part tolerances.

The misalignment in bidirectional printing can be adjusted as explained in Chapter 4, by adjusting 20the difference in print timing for the even-numbered and odd-numbered lines in the carriage motor drive program (by entering the adjustment data).

Table 2-23. Carriage Motor Control/Drive Circuit Specifications

<b>Carriage Motor</b>	
Supply voltage	36.5 ± 1 VDC
Current consumption	4.0 A (at start-up, average) 1.5 A (constant speed, average) 5.0A (deceleration, average)
Rotational speed	2665 rpm (Super Draft mode) 2000 rpm (Draft mode) 1000 rpm (NLQ mode)
Driving method	Bipolar constant current drive
<b>Encoder</b>	
Supply voltage	5 VDC ± 5% (voltage applied to the driver circuit)
output	Rectangular waveform, 2 channels, TTL level
Flutter	360° ± 4.5°
Duty cycle	180° ± 54°
Sink current	Max. 20 mA (at low level)

Table 2-24. Control Mode Circuit Operation

Control Mode	Forward Rotation		Reverse Rotation		Halt
	RUN	BRAKE	RUN	BRAKE	
CRA to CRD output	CRB and CRD are high.	All are low.	CRA and CRC are high.	All are low.	CRA and CRD are high.
CRA and CRB output.	Driven from CRA to CRB	OPEN	Driven from CRB to CRA	OPEN	SHORT

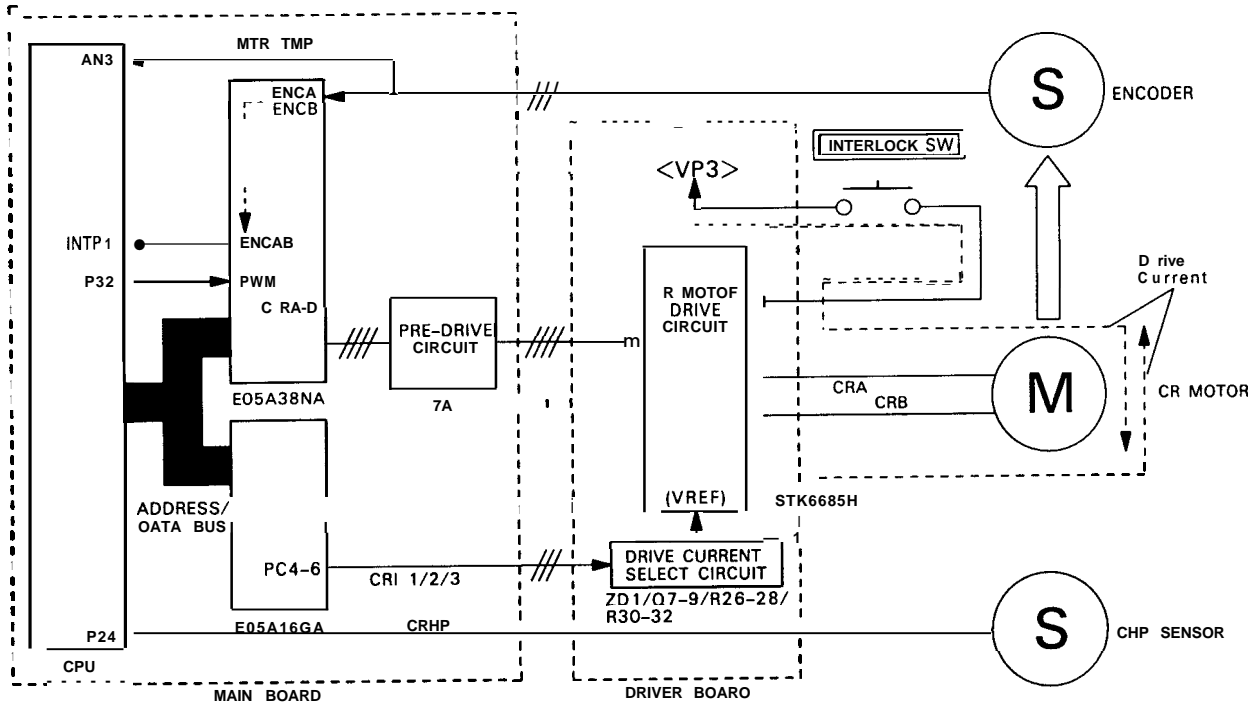

Figure 2-26. Carriage Control/Drive Circuit Block Diagram



REV.-A

### 2.3.11 Printhead Control/Drive Circuit

Figure 2-27 shows a block diagram of the printhead control/drive circuit.

The number of head coils is 18 (9 X 2 rows). The drive circuit is a constant current coil drive circuit. Each coil is driven by two transistors (PNP and NPN). The PNP supplies common currents VP 1 and VP2 and the NPN connects and disconnects grounds GP 1 and GP2, and they drive the coil with different timing. This is to increase the response speed of the head pin by driving the coil T after the PNP transistor is turned off. (See Figure 2-28.)

Therefore, the number of coil drive signals required is 2 x 18, which is 36. L and R in a signal name indicates the coil row, left or right, and P and N indicate PNP and NPN transistors, respectively.

Example: HL1 P (Drive signal for the PNP transistor for the first wire on the left row.)

The data from the host computer is expanded into image data (CG data), and latched in the E05A38NA. Since the data bus is eight bits, the data for the 36 signal lines is latched using a time sharing method. Allocation of the head data is performed in the E05A38NA (the portion shown by the oblique lines in the figure below).

The latched data is output while the FIRE signal is active. The FIRE0 and FIRE 1 signals correspond to the PNP and NPN side signals, respectively. The timing and drive times of the FIRE signals are controlled by outputs T000 and T001 from the timer in the CPU.

The drive time is varied in accordance with the gap set by the PG mechanism. (See Table 2-25.)

When the gap is wider than the reference value (thick paper): Drive time becomes longer than the reference time.

When the gap is narrower than the reference value (thin paper): Drive time becomes shorter than the reference time.

Each signal is predriven, and input to PNPprinthead driver STK66 125 or NPNprinthead driver STK66025 to turn the internal transistor on or off.

The output signals from the driver are also output to the head driver monitor circuit. As a result, when the printer power is turned on, test driving of each head coil can be performed as a part of the printer initialization sequence to check if the circuits are open or shorted.

If a circuit is open or shorted, either the HNERR (when the NPN driver side is defective) or HPERR (when the PNP driver side is defective) signal becomes active, and the CPU rings the buzzer to warn the user of an error.

The FTBL port of the E05A38NA inputs the phase switching signal for the printhead cooling fan. When the signal is received, the E05A38NA outputs the phase switching signal from the HFAN A/B port to drive the fan motor.

A thermistor is included in each internal coil of the printhead and in the printhead cooling fan, which converts the temperature into a voltage (HTMP or FTMP signal). The CPU executes sampling/holding using an internal A-D converter (ports AN 1 and AN2) to monitor the internal temperatures of the printhead and printhead cooling fan.

If the head temperature rises abnormally, temperature compensation is performed to prevent the coils from burning and to extend the life of the coils. (See Table 2-25.)

If the head temperature rises above the limit, the CPU stops printing so that the head can be cooled down by the external fan at the home position.

Driving of the head cooling fan is also halted if its temperature rises above the limit.

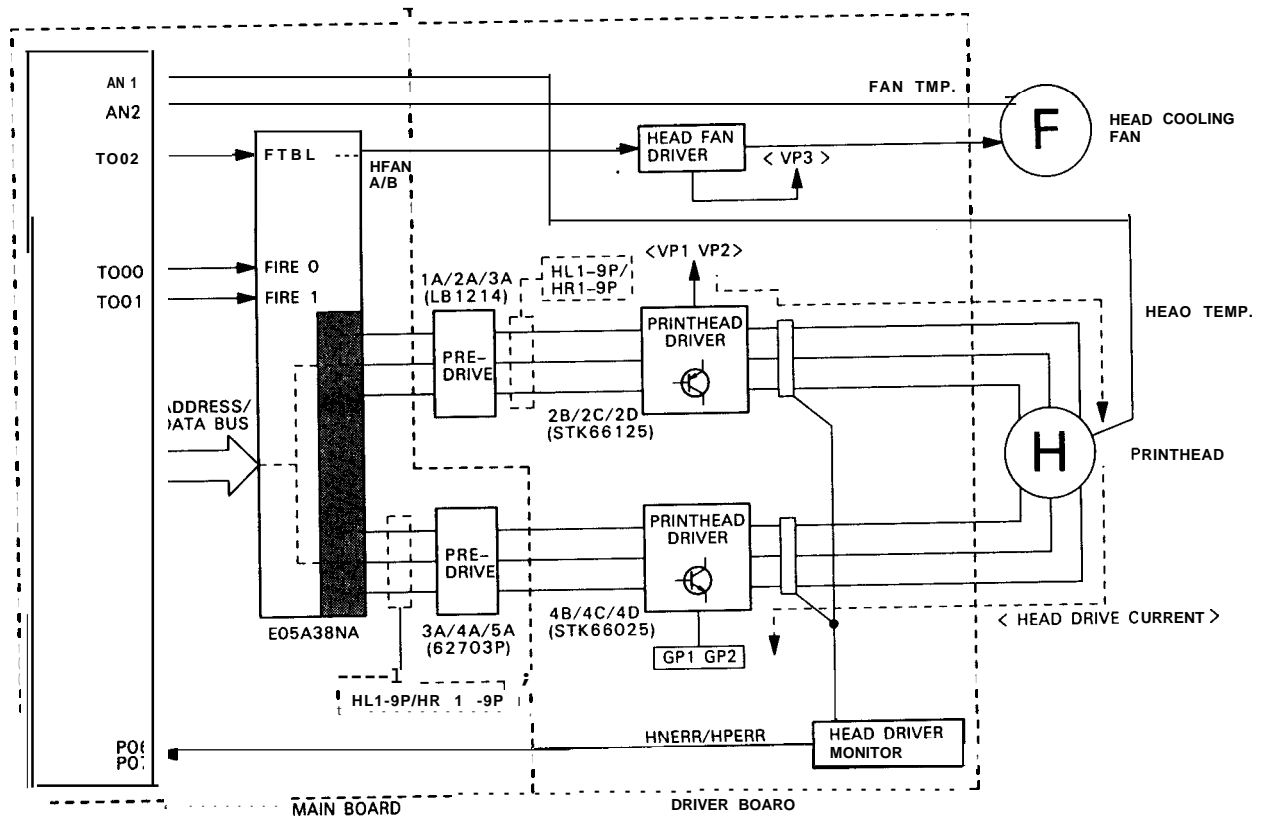

Figure 2-27. Printhead Control/Drive Circuit Block Diagram

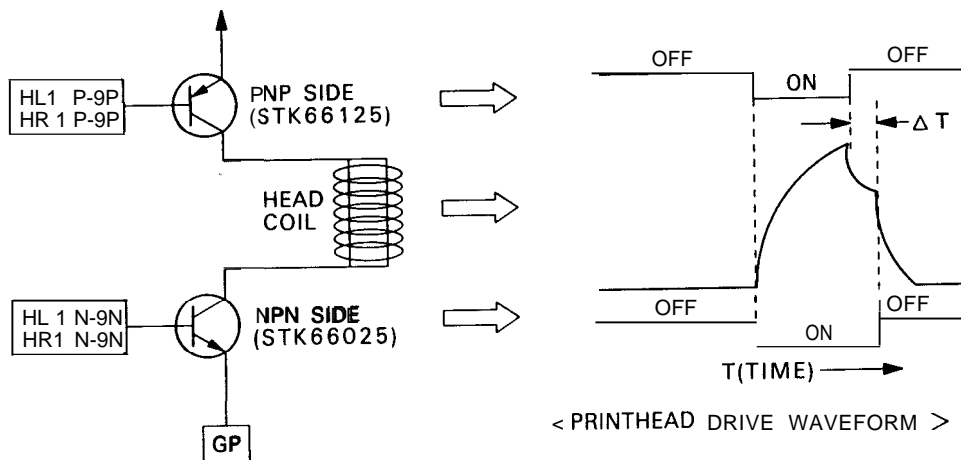

Figure 2-28. Printhead Drive Circuit Block Diagram

Table 2-25. **Printhead** Control/Drive Circuit Specifications

Printhead			
Supply voltage	36.5 ± 1 VDC		
Current consumption	7.36 A (head total, average, printing 14 dots/character)		
	8.24 A (head total, maximum, printing 14 dots/character)		
	29.07 A (head total, average, 9-pin full driving mode)		
	33.85 A (head total, maximum, 9-pin full driving mode)		
	50.85 A (head total, peak, 9-pin full driving mode)		
	54.90 A (head total, maximum peak, 9-pin full driving mode)		
	124.2 A (head total, peak, 18-pin full driving mode)		
	133.2 A (head total, maximum peak, 18-pin full driving mode)		
Response cycle	417 μsec. or more		
Drive conditions	Drive time can be varied in accordance with the paper thickness.		
	Paper thickness	Drive Time	
		PNP Driver Side	NPN Driver Side
	0.06 mm (min.)	130 to 142 μsec.	160 to 172 μsec.
0.46 mm (max.)	150 to 162 μsec.	180 to 192 μsec.	
temperature compensation control	Order	Temperature	Control
	1	120°C	Halts printing.
	2	110°C	Starts interval printing.
	3	100°C	Returns to normal printing mode.
Printhead Cooling Fan			
Supply voltage	32.5 to 35.0 VDC ± 7% (voltage applied to the drive circuit)		
Current consumption	145 to 160 mA		

# CHAPTER 3

## DISASSEMBLY AND ASSEMBLY

3.1	GENERAL .....	3-1
	3.1.1 Before Starting .....	3-1
	3.1.2 Tools .....	3-3
	3.1.3 Service Delivery Standard .....	3-5
3.2	DISASSEMBLY AND ASSEMBLY .....	3-6
	<b>3.2.1 Printhead Exchange .....</b>	<b>3-7</b>
	<b>3.2.2 ROM Exchange .....</b>	<b>3-11</b>
	<b>3.2.3 Housing Removal .....</b>	<b>3-12</b>
	<b>3.2.3.1 Top Cover Removal .....</b>	<b>3-12</b>
	<b>3.2.3.2 Side Cover Removal .....</b>	<b>3-13</b>
	<b>3.2.3.3 Front Cover Removal .....</b>	<b>3-15</b>
	<b>3.2.3.4 Upper Housing Removal .....</b>	<b>3-16</b>
	<b>3.2.3.5 Bottom Panel Removal .....</b>	<b>3-17</b>
	<b>3.2.4 Circuit Board Removal .....</b>	<b>3-19</b>
	<b>3.2.4.1 Driver Board Removal .....</b>	<b>3-19</b>
	<b>3.2.4.2 Main Board Removal .....</b>	<b>3-20</b>
	<b>3.2.4.3 Power Supply Board Removal .....</b>	<b>3-21</b>
	<b>3.2.4.4 Control Panel Unit Removal .....</b>	<b>3-22</b>
	<b>3.2.5 Interlock Switch Removal .....</b>	<b>3-23</b>
	<b>3.2.6 Printer Mechanism Removal .....</b>	<b>3-24</b>
	<b>3.2.7 Printer Mechanism Component Quick Removal .....</b>	<b>3-26</b>
	3.2.7.1 Paper Width Sensor Removal .....	3-26
	3.2.7.2 Paper Guide Support Plate Removal .....	3-26
	3.2.7.3 Carriage Home Position Sensor Removal .....	3-27
	3.2.7.4 External Fan Unit Removal .....	3-28
	3.2.7.5 Loading Solenoid Removal .....	3-29
	3.2.7.6 Ribbon Feed Motor and Tractor Select Sensor Removal .....	3-30
	3.2.7.7 Upper Paper End Sensor Removal .....	3-32
	3.2.7.8 Pull Tractor Sensor Removal .....	3-35
	3.2.7.9 Platen Removal .....	3-37
	<b>3.2.8 Printer Mechanism Component Removal .....</b>	<b>3-38</b>

<b>3.2.8.1</b>	<b>Platen Gap Sensor and Platen Gap Adjustment</b>	
	Motor Removal . . . . .	3-38
<b>3.2.8.2</b>	<b>Paper Feed Motor Removal . . . . .</b>	<b>3-40</b>
<b>3.2.8.3</b>	<b>Front Tractor Unit Removal . . . . .</b>	<b>3-42</b>
<b>3.2.8.4</b>	<b>Rear Tractor Unit Removal . . . . .</b>	<b>3-43</b>
<b>3.2.8.5</b>	<b>Carriage Motor Unit Removal . . . . .</b>	<b>3-44</b>

## LIST OF FIGURES

Figure 3-1.	Carrying the <b>DFX-8000</b> . . . . .	31
Figure 3-2.	<b>DFX-8000</b> Packing Method -1 . . . . .	3-2
Figure 3-3.	<b>DFX-8000</b> Packing Method -2. . . . .	3-2
Figure 3-4.	Disassembly Flow Chart . . . . .	3-6
Figure 3-5.	<b>DFX-8000</b> Exclusive Head Kit. . . . .	3-7
Figure 3-6.	Preparation . . . . .	3-8
Figure 3-7.	Head Cable Removal . . . . .	3-8
Figure 3-8.	Head Cable Cover Removal . . . . .	3-9
Figure 3-9.	Printed Exchange . . . . .	3-9
Figure 3-10.	Ribbon Mask Removal . . . . .	3-9
Figure 3-11.	Printhead installation. . . . .	3-10
Figure 3-12.	Lubricating to the Carriage Guide Shafts . . . . .	3-10
Figure 3-13.	ROM Exchange . . . . .	3-11
Figure 3-14.	Top Cover Removal . . . . .	<b>3-12</b>
Figure 3-15.	Power Switch Wiring Diagram . . . . .	3-13
Figure 3-16.	Side Cover Removal . . . . .	3-14
Figure 3-17.	Front Cover Removal . . . . .	3-15
Figure 3-18.	Upper Housing Removal . . . . .	3-16
Figure 3-19.	Cables . . . . .	3-17
Figure 3-20.	Bottom <b>Pannel</b> Removal -1 . . . . .	3-18
Figure 3-21.	Bottom <b>Pannel</b> Removal .2. . . . .	3-18
Figure 3-22.	Driver Board Removal . . . . .	<b>3-19</b>
Figure 3-23.	Main Board Removal . . . . .	3-20
Figure 3-24.	Power Supply Board Removal . . . . .	3-21
Figure 3-25.	Control Panel Unit Removal. . . . .	3-22
Figure 3-26.	Interlock Switch Removal . . . . .	3-23
Figure 3-27.	Printer Mechanism Removal . . . . .	3-24
Figure 3-28.	Raising the Printer Mechanism . . . . .	3-25

Figure 3-29. Paper Guide Support Plate Removal . . . . .	3-26
Figure 3-30. Carriage Home Position Sensor Removal . . . . .	3-27
Figure 3-31. External Fan Unit Removal . . . . .	3-28
Figure 3-32. Loading Solenoid Removal . . . . .	3-29
Figure 3-33. Damper, Left/Ribbon Feed Gear Removal . . . . .	3-30
Figure 3-34. R/F Change Lever Unit Removal . . . . .	3-30
Figure 3-35. R/F Change Lever Unit Disassembly . . . . .	3-31
Figure 3-36. Tractor Select Lever Mounting Position . . . . .	3-31
Figure 3-37. Paper Bail Removal(Left).. . . . .	3-32
Figure 3-38. Paper Bail Removal(Right).. . . . .	3-33
Figure 3-39. Paper Bail removal . . . . .	3-33
Figure 3-40. Upper Paper Guide Removal . . . . .	3-34
Figure 3-41. Upper Paper Guide Assembly . . . . .	3-34
Figure 3-42. Terminal Board Removal . . . . .	3-35
Figure 3-43. Tension Roller Shaft Removal-1 . . . . .	3-35
Figure 3-44. Tension Roller Shaft Removal-2 . . . . .	3-36
Figure 3-45. Pull Tractor Sensor Removal . . . . .	3-36
Figure 3-46. Platen Removal . . . . .	3-37
Figure 3-47. Platen Gap Sensor and Platen Gap Adjustment	
Motor Removal . . . . .	3-38
Figure 3-48. Platen Gap Sensor Assembly Point.....	3-39
Figure 3-49. Wire Saddle and Holder . . . . .	3-40
Figure 3-50. Paper Feed Motor Removal . . . . .	3-40
Figure 3-51. Left Frame Gear Connection . . . . .	3-41
Figure 3-52. Front Tractor Unit Removal-1 . . . . .	3-42
Figure 3-53. Front Tractor Unit Removal-2.....	3-42
Figure 3-54. Rear tractor Unit Removal-1 . . . . .	3-43
Figure 3-55. Rear Tractor Unit Removal-2.....	3-43
Figure 3-56. Carriage Motor Unit Removal . . . . .	3-44

## LIST OF TABLES

Table 3-1. Tools . . . . .	3-3
Table 3-2. Special Tools.....	3-3
Table 3-3. Small Parts Abbreviations List . . . . .	3-4
Table 3-4. Abbreviated Part Names of Screws . . . . .	3-4
Table 3-5. Service Delivery Standard Check List . . . . .	3-5

## 3.1 GENERAL

This section describes the disassembly and assembly of the DFX-8000.

### 3.1.1 Before Starting

Read the following warnings before assembly or disassembly.

#### DANGER

- Because this printer weighs 30 Kg and is much larger and heavier than existing models, careful attention should be paid when handling it. It must be carried by two or more persons, supporting it from the bottom as shown in Figure 3-1. Never lift it by holding the front cover because the front cover could come off.
- Before disassembling, assembling, and adjusting the printer, be sure to disconnect the AC power cord.
- The main board of the printer is equipped with a lithium battery. Before disassembling the main board, read the following cautions so that you can handle the battery safely. Also be careful of its storage condition.
  - a. Do not store lithium batteries stacked together or with other metal parts, to prevent the + and - sides from making electrical contact, which could cause a short circuit.  
(If a battery is shorted, a large current can flow. The battery could ignite or burst due to the heat generated.)
  - b. Do not heat the battery. Do not throw it away into a fire.
  - c. Do not solder any portion other than the connection terminals.  
(The battery might burn or burst if the internal solution leaks out or if it shorts internally. If the solution in the battery leaks and it is left as it is for a long time, the printer components around the battery could be damaged.)
  - d. Do not charge the battery.  
(If it is charged, gas would be generated, and it could ignite or burst.)
  - e. Do not disassemble the battery, or deform it using pressure.  
(The gas in the battery could irritate your throat, or the battery might burst or ignite, and the solution might leak.)
  - f. Do not mount the battery (+ and - sides reversed).  
(If the + and --sides are reversed, the battery might ignite or burst due to a short circuit.)
- The printhead reaches very high temperatures, and if you place your hand on it, it could burn you. Always be sure that the printhead is cool when you handle it.
- The power cord and interface cable must be disconnected before moving the printer.
- Because the components are larger and heavier than those of previous models, wear gloves to protect your hands when handling the DFX-8000.

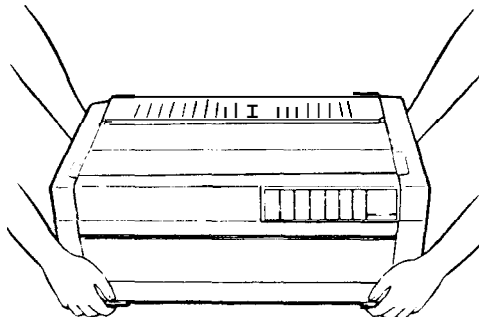

Figure 3-1. Carrying the DFX-8000

**WARNING**

● This printer must be properly packed in the correct container for transportation as shown in Figure 3-2. The following four items must be used for transportation, as shown in Figure 3-3:

- a. Transport locking brackets
- b. Carriage guide shaft supporting bar
- c. Head protector
- d. Form packing for paper bail

If the unit is not properly packed, it could be damaged during transportation.

- The paper and ribbon should be removed before transportation or disassembly.
- You may be required to turn or rotate the unit when working on it, so place it on a clean, thick cloth, such as a blanket, before starting.
- After finishing, do not forget to lubricate and reassemble the unit following the instructions in Chapter 6, because a considerable amount of oil may be removed during maintenance or repair work.

Also, be sure to clean the unit as described in Chapter 6.

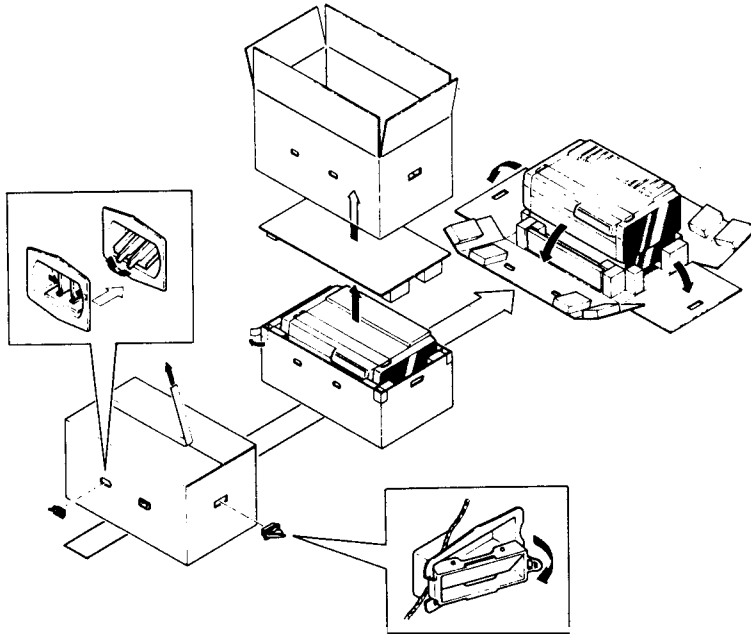

Figure 3-2. DFX-8000 Packing Method -1

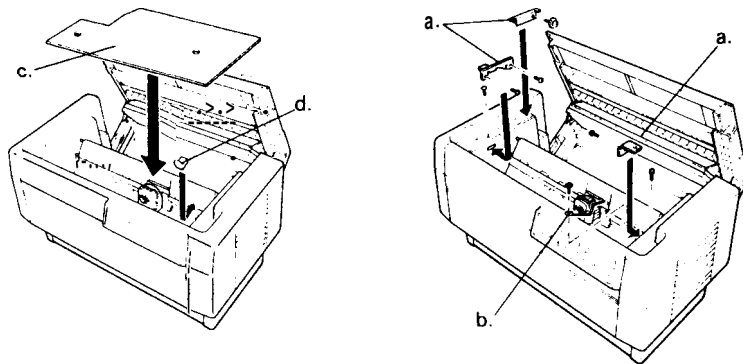

Figure 3-3. DFX-8000 Packing Method -2



### 3.1.2 Tools

When assembling, and disassembling this printer, the following tools are required.

**NOTE:** Refer to Chapter 5 for trouble shooting tools, and to Chapter 6 for maintenance, lubrication and adhesion tools.

Table 3-1. Tools

Designation	Type	Class	Part No.
Phillips screw driver No.2	o	A	B743800200
Phillips screw driver No. 1	0	A	B743800
Slotted Screw driver No.	o	A	B743800300
Box driver (7mm)	O	A	B74 1700200
E-ring holder #3	o	A	B740800500
E-ring holder #6	o	A	B740800800
Round nose pliers	o	A	B740400 100
Diagonal cutting nipper	o	A	B740500 100
Tweezers	o	A	B64 1000100
Electric soldering iron	o	A	B740200 100
Lift handle #E656	E	A	B7651 11001
Electric screw driver (phillips head, adjustable torque)	o	B	—

O: Commercially available tool

E: EPSON exclusive tool

A: Mandatory

B: Recommended

Table 3-2. Special Tools

No.	Name	Figure	Description	Part No
#E656	Lift Handle		Lifting handle for removing the printer mechanism	B7651 11001









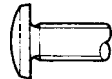

● Screw designation

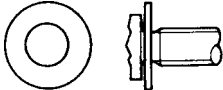
All small parts, such as screws and washers, are indicated by abbreviated names.

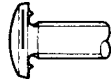
Table 3-3. Small Parts Abbreviations List

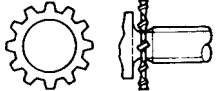
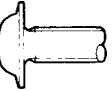
Abbreviation	Part Name
Cs	Cup Screw
CB	Cross-Bind-head screw
CBO	Cross-Bind-head with Outside-toothed washer
CBB	Cross-Bind-head B-tight
CBS	Cross-Bind-head S-tight
CBS (0)	Cross-Bind-head S-tight with Outside-toothed washer
CPS	Cross-Pan-head with Spring washer
CPS (o)	Cross-Pan-head S-tight with Outside-toothed washer
CPS (P)	Cross-Pan-head with S-tight with Plain washer
CP (o)	Cross-Pan-head with Outside-toothed washer
CP (P)	Cross-Pan-head with Plain washer
HNO	Hexagon Nut with Outside toothed lock washer
PW	Plain Washer
LS	Leaf Spring
RE	Retaining ring type-E

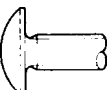
Table 3-4. Abbreviated Part Names of Screws

Head		Body	Washer (assembled)
Top	Side		
gross-recessed head 	1. Bind 	1. Normal 	1. Plain washer 
1. Slotted head 	(with Notch) 2. Pan 	2. S-tight 	2. Outside toothed lock washer 
	3. Cup 	3. B-tight 	3. Spring washer 
	4. Truss 	4. Tapping  	

### 3.1.3 Service Delivery Standard

After repairing and testing are completed, be sure to perform additional confirmation, referring to Table 3-5. Copy Table 3-5, and use it as a check list.

Table 3-5. Service Delivery Standard Check List

Item	Standard	Check
Are all necessary adjustments completed? Are the results of the adjustments within the specified tolerances?	Refer to Chapter 4.	
Check that lubrication and adhesion are correct.	Refer to Chapter 6.	
Visually inspect the inside of the printer	Check the wires for proper wiring. (No wire should be caught.)	
	Check the screws for proper fastening. (The screws should not be tightened too much.)	
	Check the cables for cuts, bends, and proper connection.	
	Check the AC inlet for proper connection. (It should not be slanted.)	
	Determine if cleaning is necessary.	
Check the DIP switch settings.	Refer to Chapter 1.	
Visually inspect the outside of the printer.	Check that there are no scratches, stains, gouges, or deformation.	

## 3.2 DISASSEMBLY AND ASSEMBLY

**DANGER**

● Carefully read the cautions in the preceding section “3. 1 BEFORE STARTING”, and follow the instructions.

Here we will describe how to assemble and disassemble the printer, by referring to the disassembly sequence. The sequence for assembly is basically the reverse of that for disassembly, and any point that demands special attention is described as an “ASSEMBLY POINT”. We will also omit simple disassembly operations; please refer to the exploded diagram for details.

In addition, < ADJUSTMENT REQUIRED> is included to explain any item that should be adjusted after assembling the unit. Please read these carefully before working on the printer.

See the Figures in the appendix for the exploded diagram and parts name list Figure 3-4 shows a flow-chart for disassembly procedure.

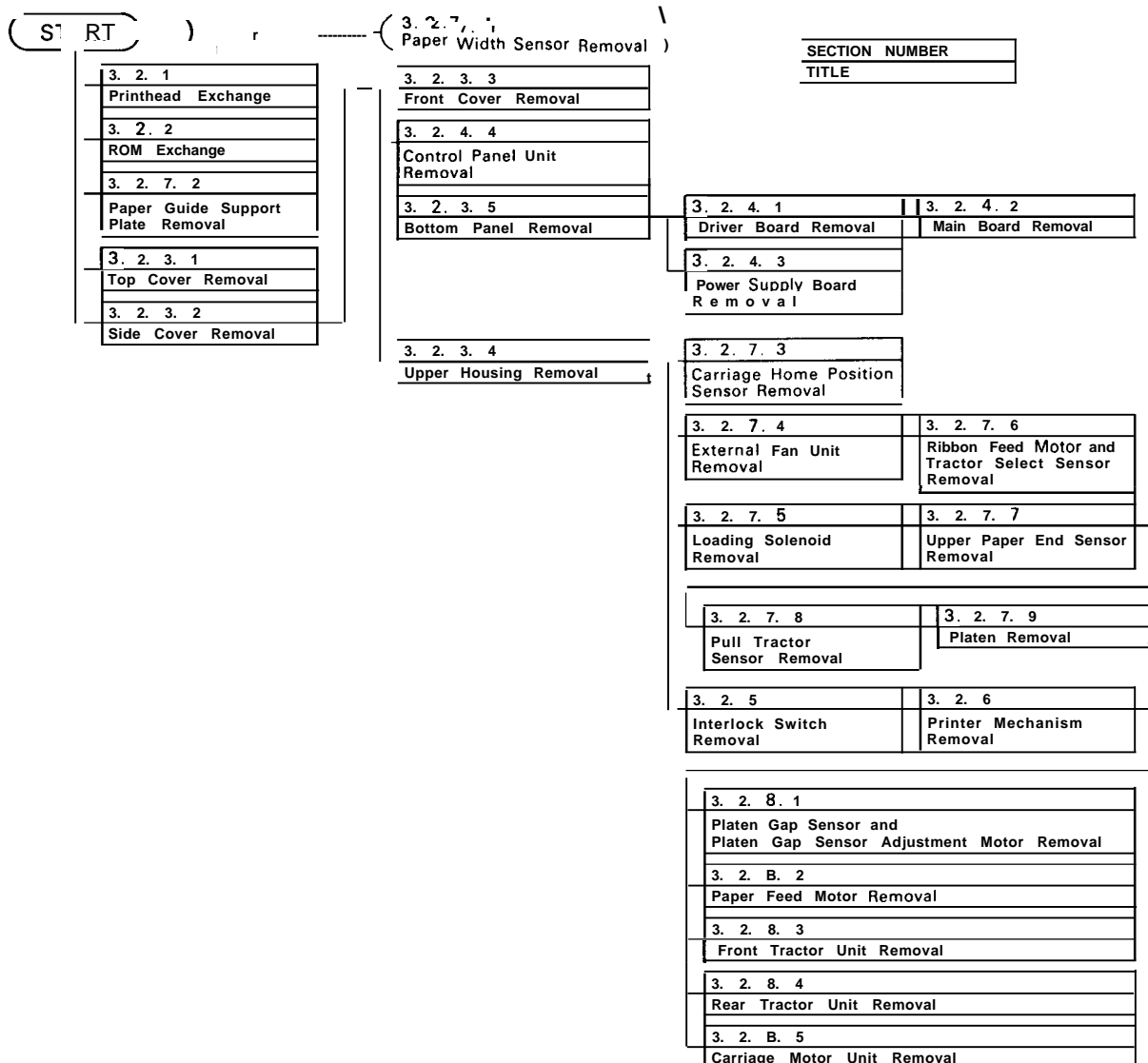
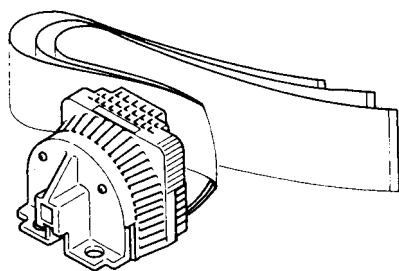

Figure 3-4. Disassembly Flow Chart

### 3.2.1 Printhead Exchange

The printhead can be changed without disassembling the unit.

Use the exclusive head kit for printhead exchange on the DFX-8000. When you receive the kit, check that all of the following are included.



Printhead unit

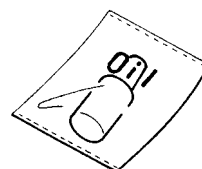

Oil (O-2)

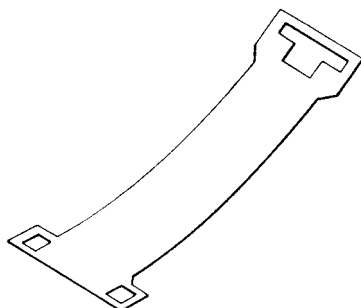

Head cable protection sheet

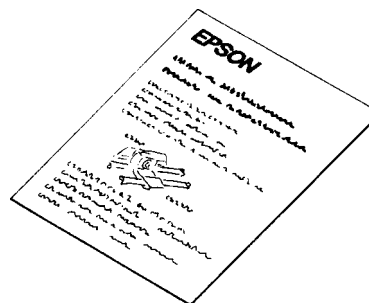

Instruction manual

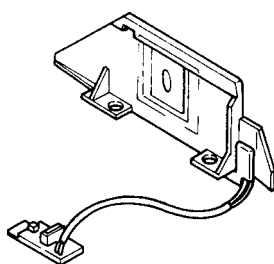

Ribbon mask assembly

Figure 3-5. DFX-8000 Exclusive Head Kit

The description hereafter is the same as the contents of the above Instruction Manual, so you may refer to this section or to the Instruction Manual.

**WARNING**

- Be careful not to break the tabs when taking off the connector cover.
- Be careful not to break the head cable holder latch when removing it. Use a slotted screwdriver if necessary.
- When replacing the printhead on the DFX-8000, be sure to follow the instructions in this manual. If the printhead is replaced without following the instructions, the performance of the printhead cannot be guaranteed.

**Step 1:** Turn the printer power off, then disconnect the AC cable.

**Step 2:** Open the cover, then remove the ribbon cartridge.

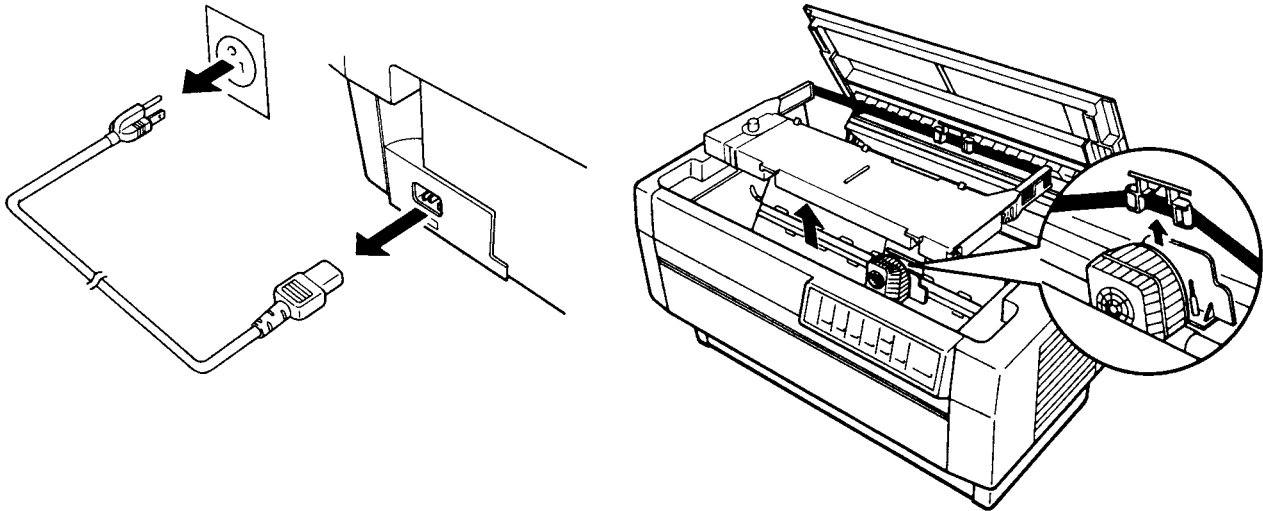
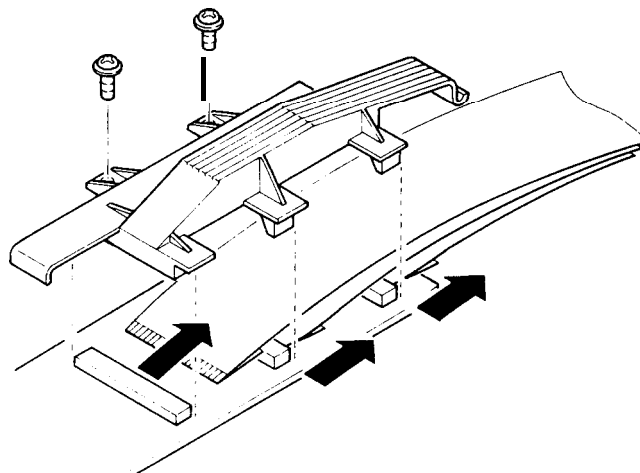

**Figure 3-6. Preparation**

**Step 3:** Remove the two screws securing the connector cover, then remove the connector cover.

**Step 4:** Disconnect the three head cables from the connector.

- NOTES:**
1. When disconnecting the cables, hold the cable close to the connector.
  2. When disconnecting the cable, pull it slowly and horizontally to the right, as viewed from the front side.
  3. When disconnecting the cable, hold the connector to prevent it from being pulled off the board.



**Figure 3-7. Head Cable Removal**

- Step 5:** Unlock the two head cable cover latches by pressing them with your fingers, then remove the cover by sliding it to the right. Remove the cable protection sheet too.

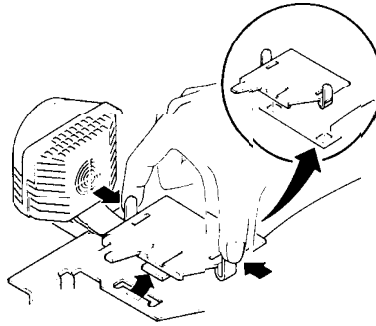

**Figure 3-8. Head Cable Cover Removal**

- Step 6:** Unlock the relay board assembly connector latch, disconnect the cable for the paper width sensor.
- Step 7:** Move the carriage to about the 90th column, remove the two screws securing the printhead, then remove the printhead.

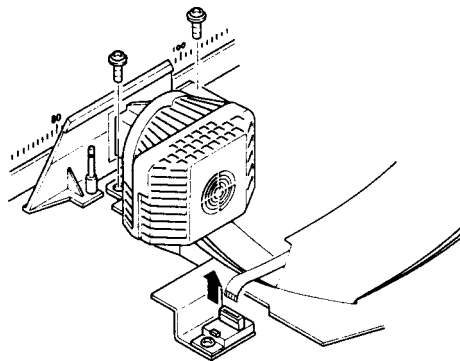

**Figure 3-9. Printhead Exchange**

- Step 8:** Remove the screw securing the relay board assembly to the carriage, then remove the relay board assembly.
- Step 9:** Remove the two shafts securing the ribbon mask to the carriage using a slotted screwdriver, then remove the ribbon mask.

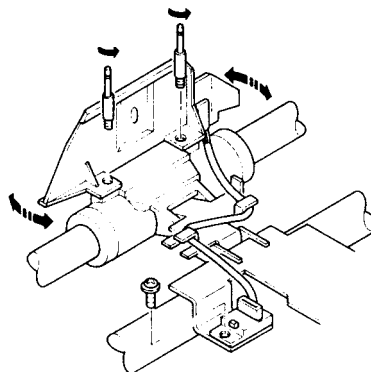

**Figure 3-10. Ribbon Mask Removal**

REV.-A

**Step 10:** Install the new printhead, ribbon mask, and cable protection sheet by following Steps 1 to 9 in the reverse order.

**Step 11:** Replace the ribbon mask with a new one. Set the cable of the paper width sensor as shown in Figure 3-10. After installation, check that the ribbon mask is a little loose.

**Step 12:** Install the new printhead (torque the screws to 12 kg.cm). Replace the head cable protection sheet with a new one, then connect the head cables to the connector.

**ASSEMBLY POINTS:**

1. Confirm that the cables are connected correctly. (Refer to Figure 3-9.)
2. Tighten the screws while pulling the printhead backward as shown below to secure the printhead firmly.

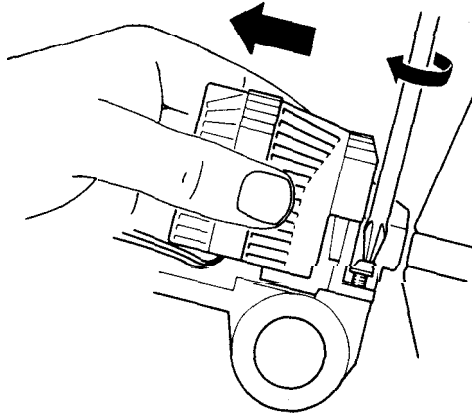

**Figure 3-11. Printhead Installation**

**Step 13:** Install the head cable cover and the connector cover.

**Step 14:** Wipe off any stains from the carriage guide shaft, lubricate both ends of the carriage guide shaft with the included oil (02), and spread the oil over the shaft by moving the carriage manually.

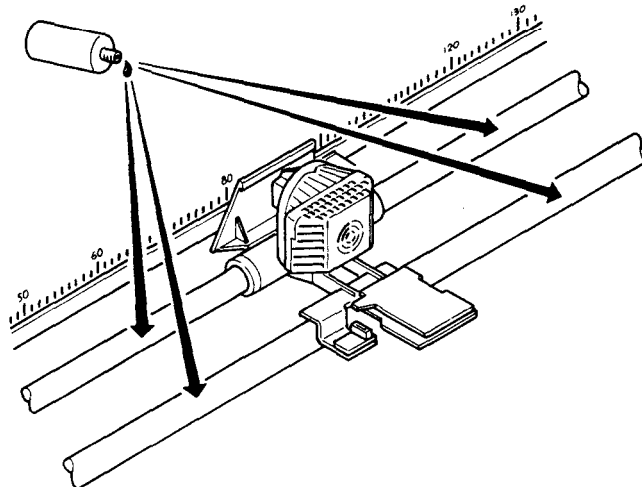

**Figure 3-12. Lubricating to the Carriage Guide Shafts**

**Step 15:** Perform the adjustment described in Section 4.2 Printhead Adjustment Value Writing.

**ADJUSTMENT REQUIRED**

You must be performed the following adjustment when the printhead is replaced.

- **PRINTHEAD ADJUSTMENT VALUE WRITING** (See section 4.2.)



### 3.2.2 ROM Exchange

The ROM can be changed without disassembling the unit

#### WARNING

- It is recommended that you remove the top cover prior to rotating the unit. Refer to section 3.2.3.1 for removing the top cover.
- If you rotate the unit with the top cover on, be sure not to impose too large of a load on the top cover or other components.
- A thick, soft cloth should be spread out under the unit before starting to work on it.
- Remove the ROM carefully so as not to damage the board.
- Before mounting the ROM, check the orientation by observing the INDEX mark on the socket, and insert the ROM carefully so as not to damage the ROM pins or board.

**Step 1:** Rotate the printer and lay it on its back while supporting the top cover so that it doesn't come open.

**Step 2:** Remove the CBB(M4X8) screws holding the ROM cover, remove the cover, and exchange the ROM.

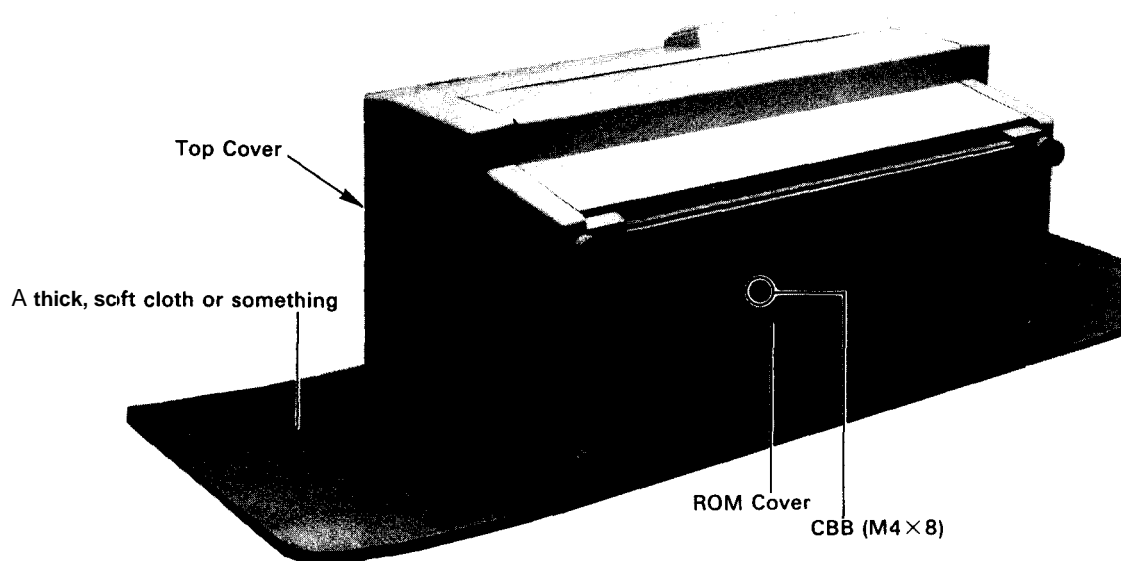

Figure 3-13. ROM Exchange

REV.-A

### 3.2.3 Housing Removal

Here we will describe the procedure for removing the housing.

#### 3.2.3.1 Top Cover Removal

**WARNING**

- Due to the weight of the top cover, it can overload and damage the rear cover hinge unless you support it while removing the screws.  
When taking off the top cover, one person should remove the screws while the other person supports it.

**Step 1:** Open the top cover.

**Step 2:** While supporting the top cover, remove the four screws fixing the cover to the hinge (two on the right, two on the left).

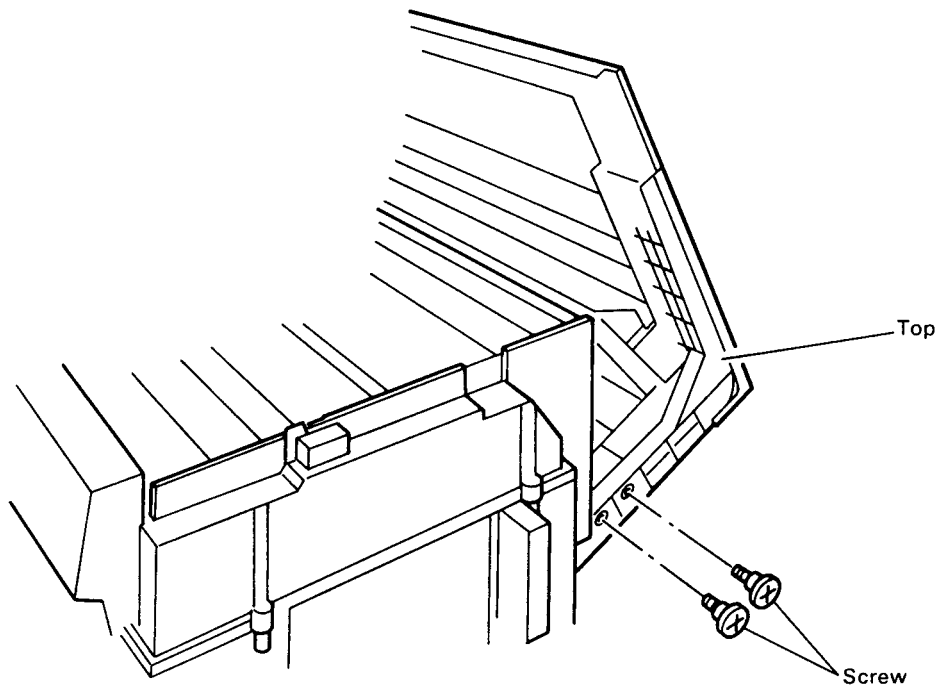

Figure 3-14. Top Cover Removal

## 3.2.3.2 Side Cover Removal

**DANGER**

When reconnecting the cable to the power switch (inlet side, power supply board side), be sure to connect the cables correctly. Otherwise, the AC input could short and burn.

When installing the power switch, be sure to connect the wires as shown in Figure 3-15, and check them for proper connection.

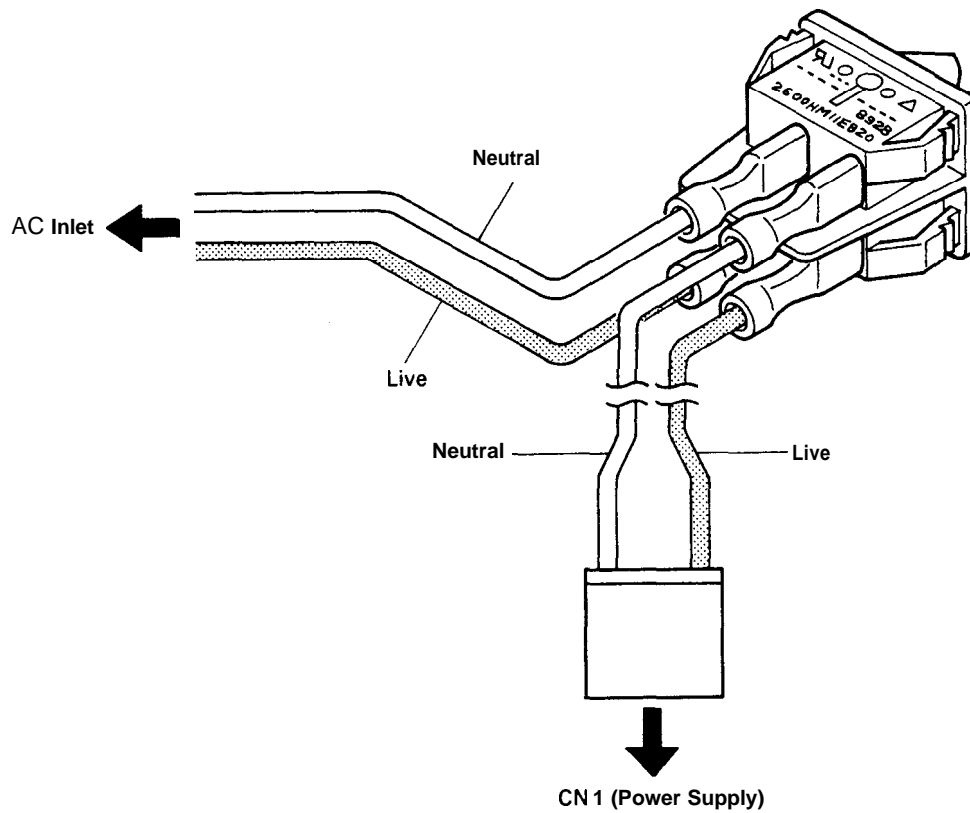

Figure 3-15. Power Switch Wiring Diagram

REV.-A

Step 1: Open the top cover

Step2: Remove the four CBB(M4 X 16) screws holding the left side cover, and remove it. Remove the right side cover in the same way.

Step3: Disconnect the cables from the power switch at the CN 1 on the power supply board.

Step4: Disconnect the cables (See Figure 3- 15) from the AC inlet at the power switch.  
(To loose the cable from the terminals of the power switch, using the tip of slotted head screw driver)

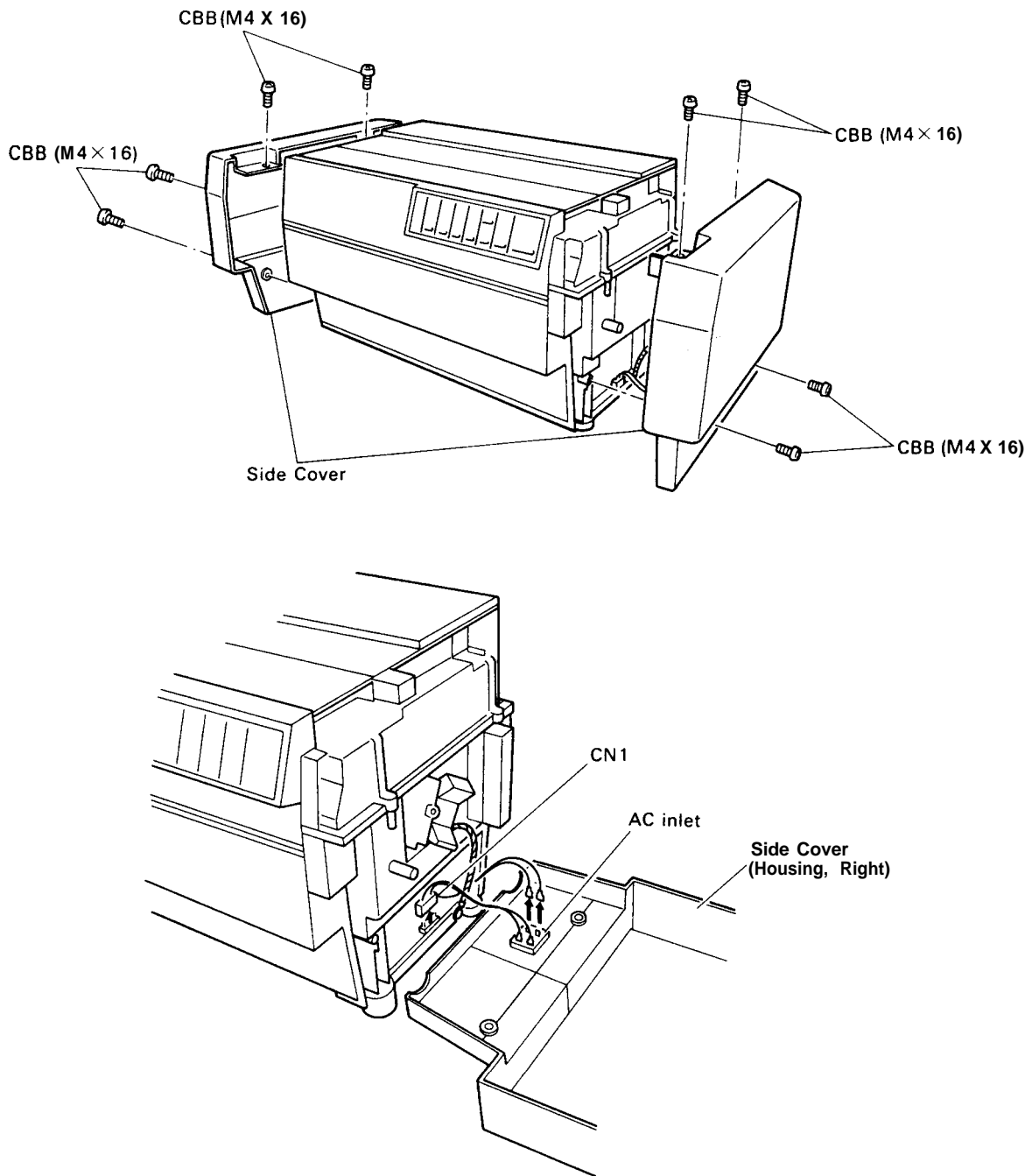

Figure 3-16. Side Cover Removal

### 3.2.3.3 Front Cover Removal

Step 1: Remove the side cover. (Refer to section 3.2.3.2.)

Step 2: Remove two CBB(M4 X 16) screws fixing the left front cover hinge to the lower case. Remove the screws from the right hinge also.

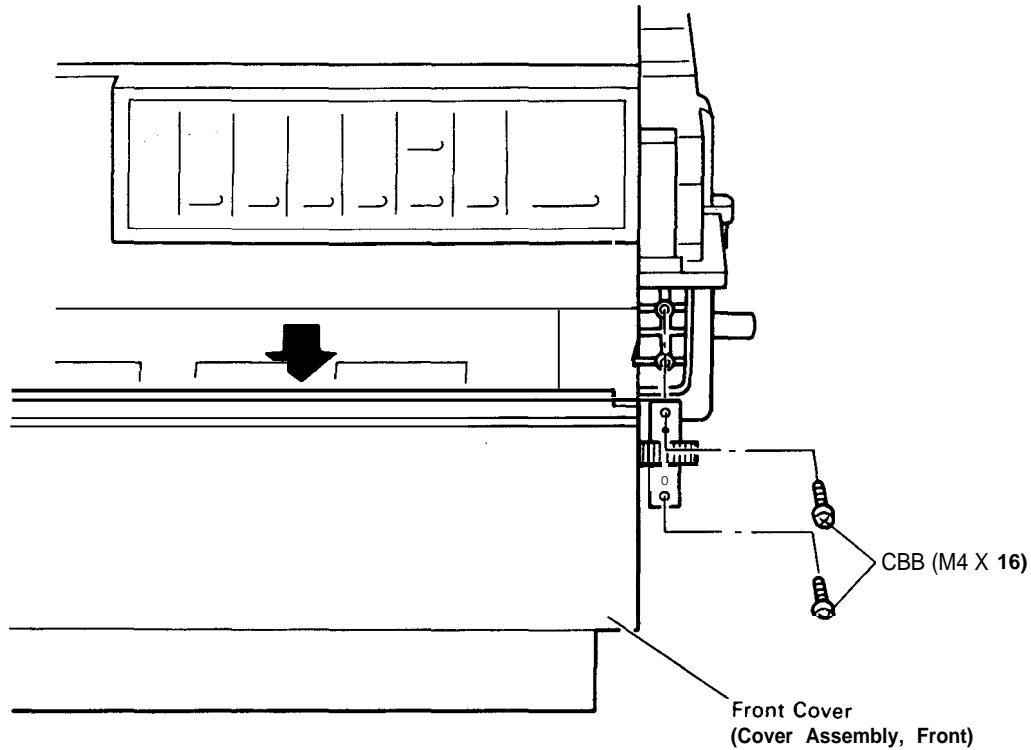

Figure 3-17. Front Cover Removal

#### ASSEMBLY POINT:

- Before attaching the front cover hinges to the front cover, check the letters stamped on them to identify the left and right hinges. (L: Left side, R: Right side)

## 3.2.3.5 Bottom Panel Removal

**WARNING**

- It is recommended that you take off the top cover prior to tilting the unit as shown below. Refer to section 3.2.3.1 for top cover removal.
- When tilting the unit without removing the top cover, careful attention should be paid so as not to overload the top cover or other components.
- Spread a thick, soft cloth under the printer before starting to work on it.
- When attaching the bottom panel, be sure that the parallel interface cable latch is not caught between the lower case and the panel.

- Step 1: Take off the side cover. (Refer to section 3.2.3.2.)
- Step 2: Open the rear cover. Remove the two CBS (0) (M3 X 6) screws used to fix the earth lines of the standard parallel and optional interface.
- Step 3: Tilt the unit and lay it on its back while supporting the top cover to protect it from scratches.
- Step 4: Remove the three CBS (0) (M4 X 8) screws fixing the right and left earth lines (green) to the base plate. (Two at the left, one at the right)
- Step 5: Disconnect the cables from connectors CN7, CN8, CN9 and CN 10 at the left side of the main board. Withdraw the cables from the driver board at the left side of the printer mechanism. (A, B, C in figure below)

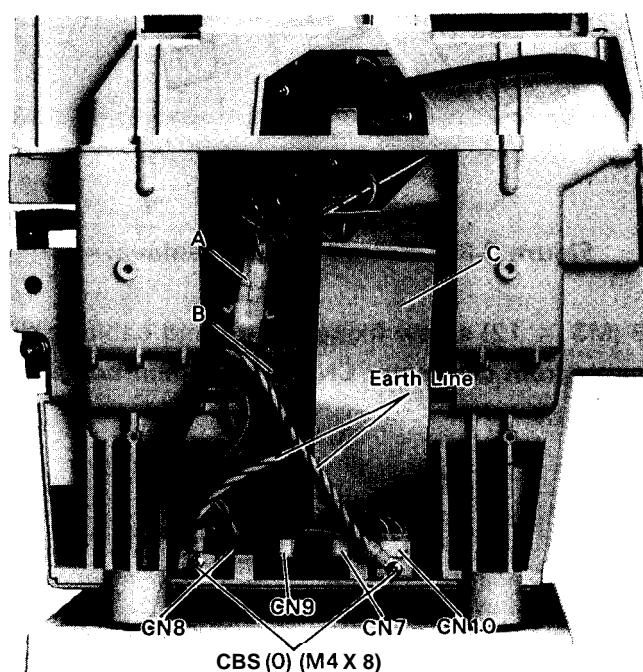

Figure 3-19. Cables

REV.-A

### 3.2.3.4 Upper Housing Removal

- Step 1: Remove the side cover. (Refer to section 3.2.3.2.)
- Step 2: Open the top cover. Disconnect connectors CN8 and CN9 from the left side of the main board.
- Step 3: Remove the two CBB(M4 X 10) screws holding the upper panel and raise it. Withdraw the CN8 cable from the gap between the lower case and the upper case.
- Step 4: Remove the six CBB(M4 X 16) screws and two CBB(M3 X 10) screws holding the upper housing and raise it. Withdraw the CN9 cable from the gap between the lower case and the upper case.

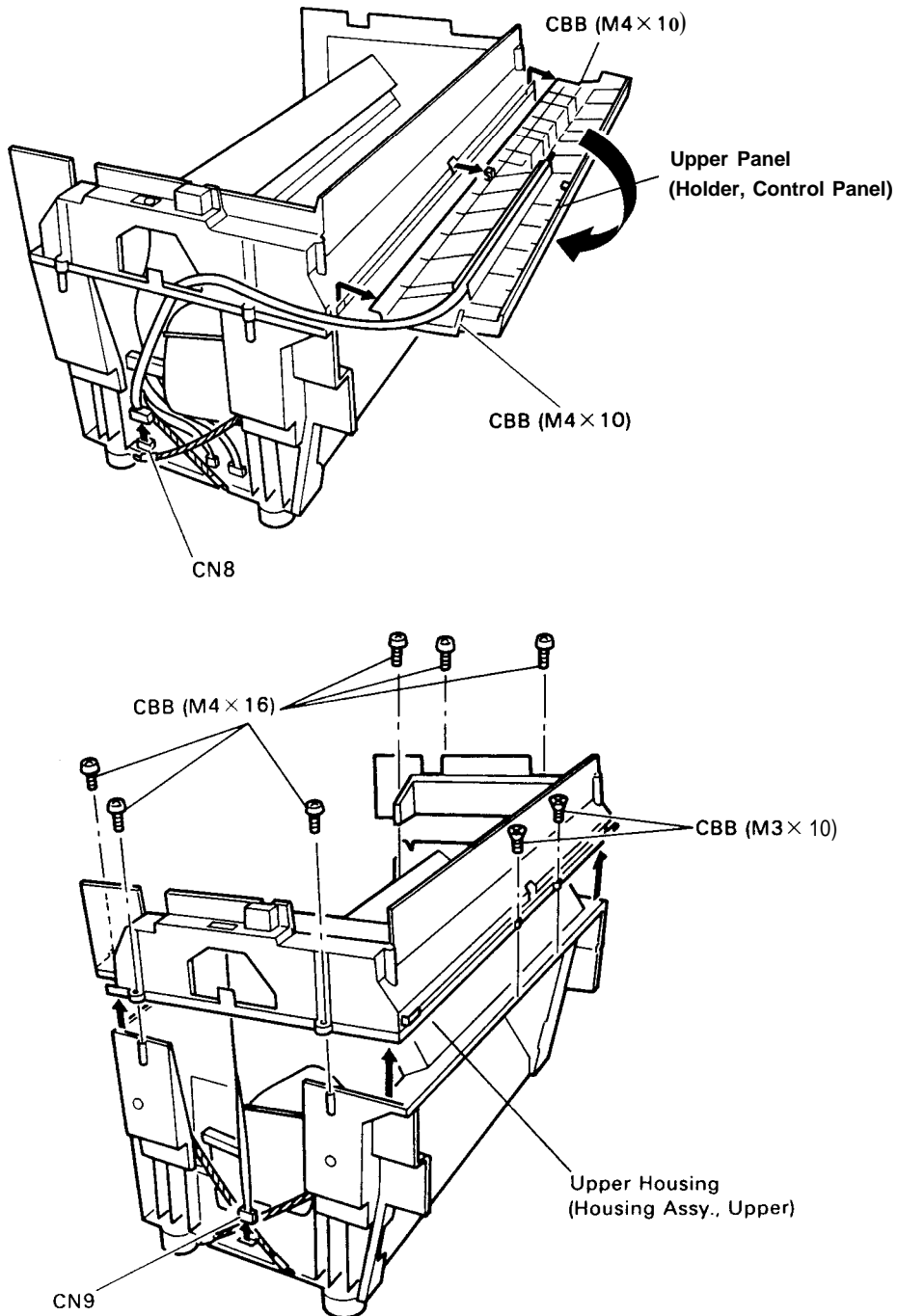
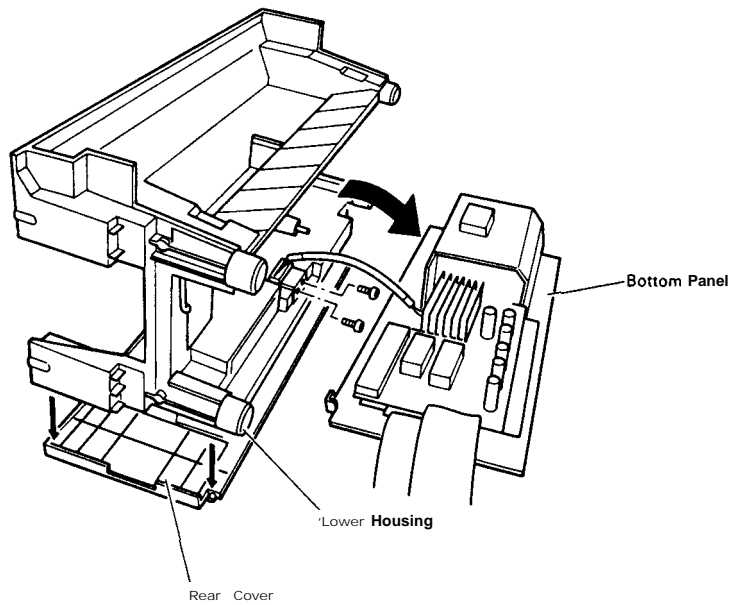
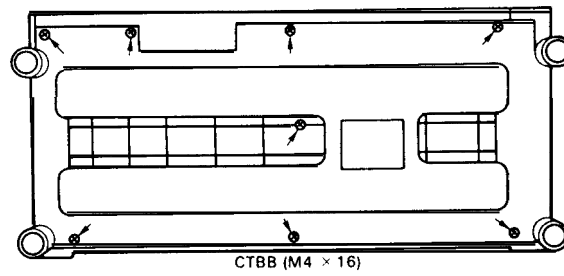

Figure 3-18. Upper Housing Removal

REV.-A

**Step 7:** Remove the eight CTBB(M4 X 16) screws fixing the bottom panel to the lower housing. Draw the bottom panel 5 inches toward you while keeping it erect.

**Step 8:** Slowly turn the bottom panel down towards you.



**Figure 3-20. Bottom Panel Removal -1**

**Step 9:** Remove the CBB(M3 X 12) screw fixing the ground cable to the base plate.

**Step 10:** Disconnect the cable from connector CN2 on the main board.

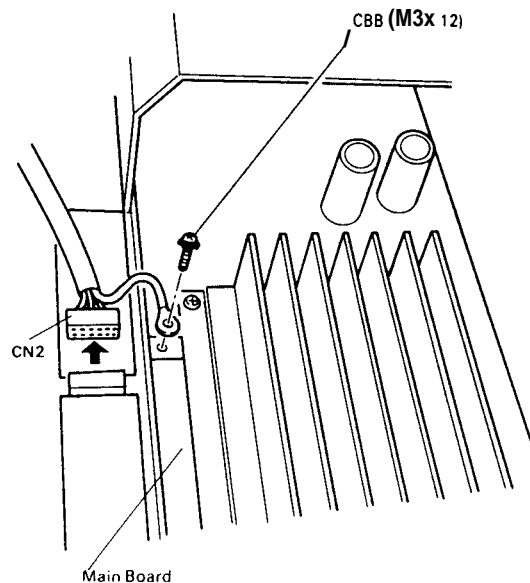

**Figure 3-21. Bottom Panel Removal -2**



### 3.2.4 Circuit Board Removal

Here we will describe how to remove the circuit boards and the required disassembly.

#### 3.2.4.1 Driver Board Removal

Step 1: Remove the bottom panel. (Refer to section 3.2.3.5.)

Step 2: Remove the cables running from connectors CN 1 and CN2 at the driver board.

Step 3: Remove the three CBB (M3 X 12) screws fixing the driver board to the base plate, and remove the driver board.

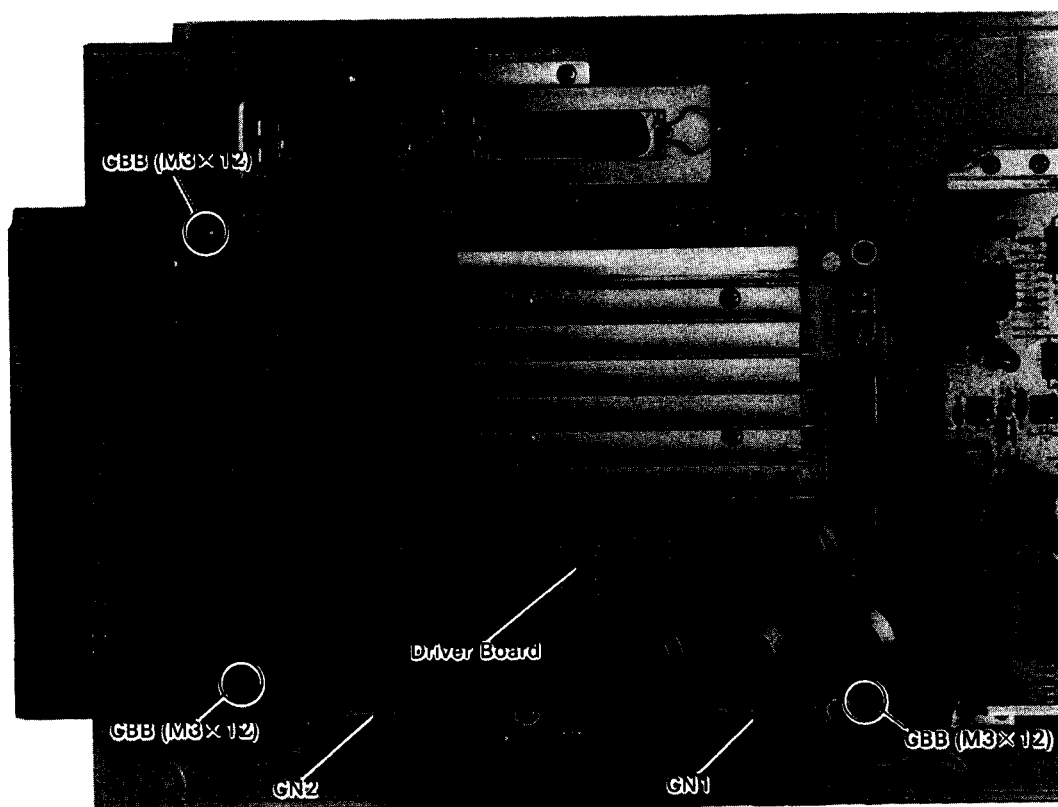

Figure 3-22. Driver Board Removal

REV.-A

### 3.2.4.2 Main Board Removal

- Step 1: Remove the driver board unit. (Refer to section 3.2.4. 1.)
- Step 2: Remove the cable running from connector CN4 at the main board.
- Step 3: Remove the two CBB (M3× 12) screws and the two CBS (0) (M3 X 8) screws fixing the main board to the base plate, and remove the main board.

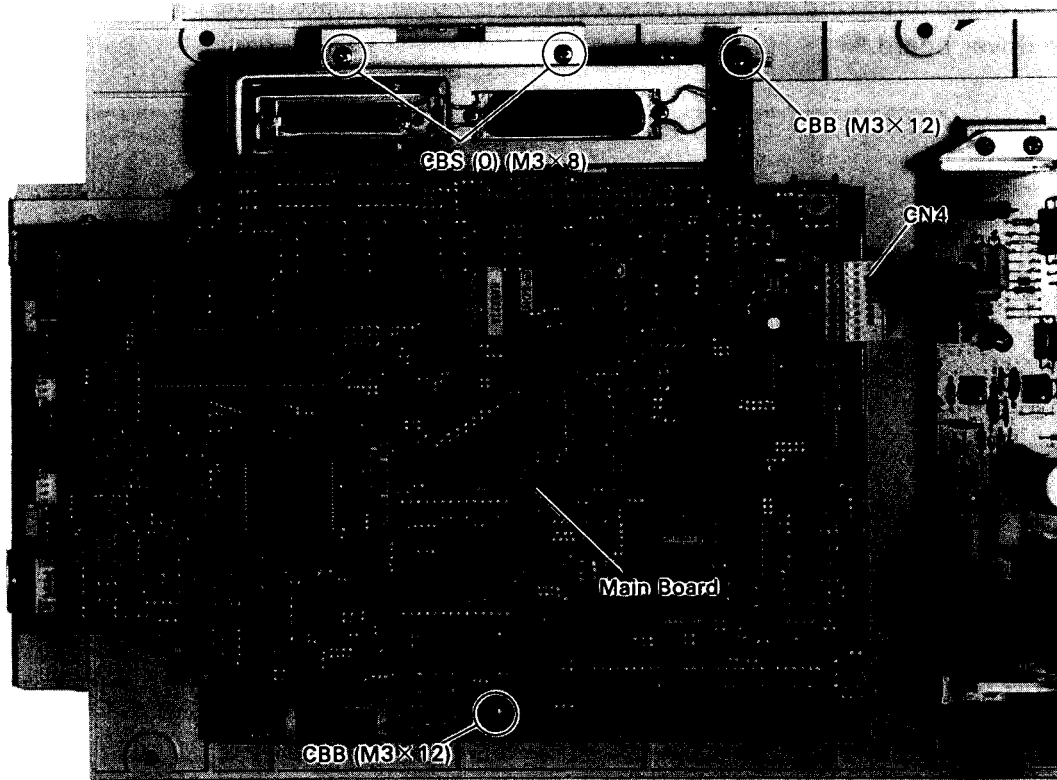

Figure 3-23. Main Board Removal

#### ADJUSTMENT REQUIRED

The following adjustments are required when the main board is replaced.

- Printhead Adjustment Value Writing (See section 4.2.)
- Bi-directional Printing Adjustment (See section 4.3.)

### 3.2.4.3 Power Supply Board Removal

- Step 1: Remove the bottom panel. (Refer to section 3.2.3.5.)
- Step 2: Remove the cables running from connectors CN 1, CN2, CN3 and CN4 at the power supply board.
- Step 3: Remove the six CBB(M3 X 12) screws and the CBS (0) (M3 X 8) screw fixing the power supply board to the base plate, and remove the power supply board.

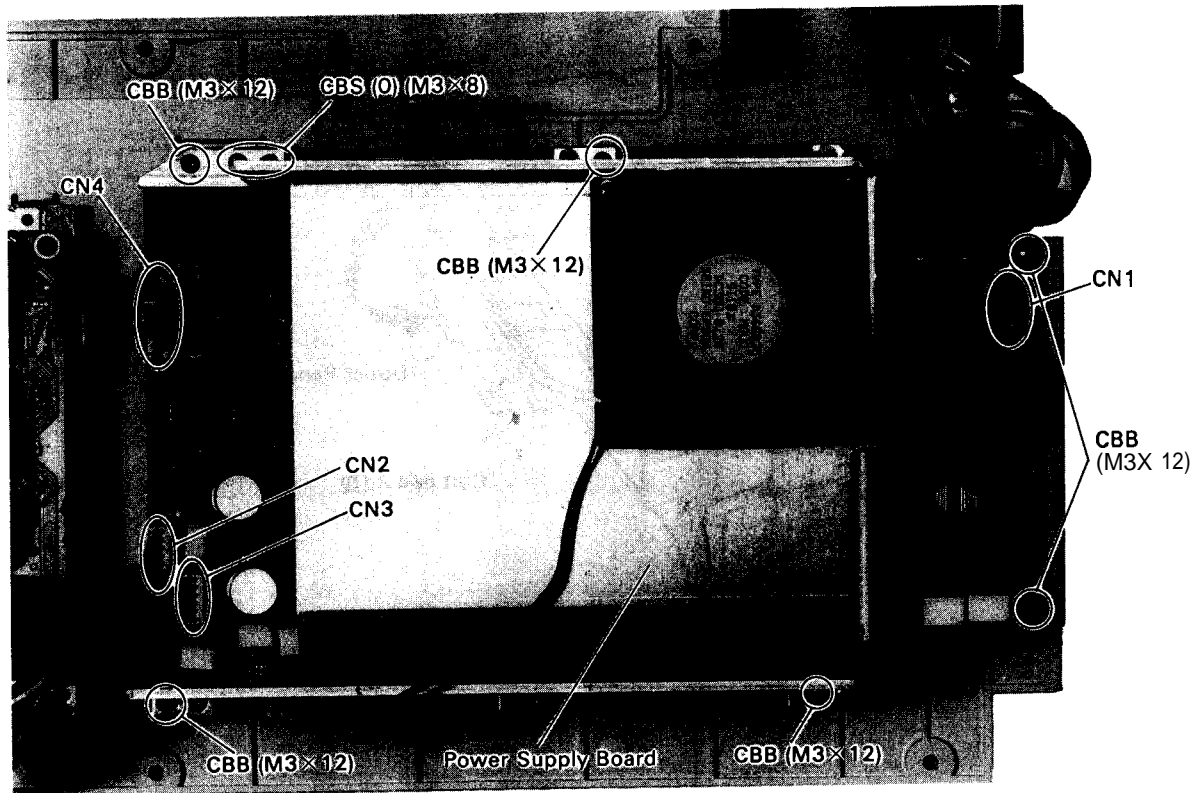

Figure 3-24. Power Supply Board Removal

REV.-A

### 3.2.4.4 Control Panel Unit Removal

- Step 1: Remove the side cover. (Refer to section 3.2.3.2.)
- Step 2: Open the top cover. Disconnect connectors CN8 from the left side of the main board.
- Step 3: Remove the two CBB(M4 X 10) screws holding the upper panel and raise it. Meanwhile, withdraw the CN8 cable from the gap between the lower and upper housings.
- Step 4: Remove the CBB(M4 X 10) screw fixing the control panel unit to the upper panel.
- Step 5: Spread the two tabs fixing the control panel unit to the upper panel using your fingers, and remove the control panel unit.

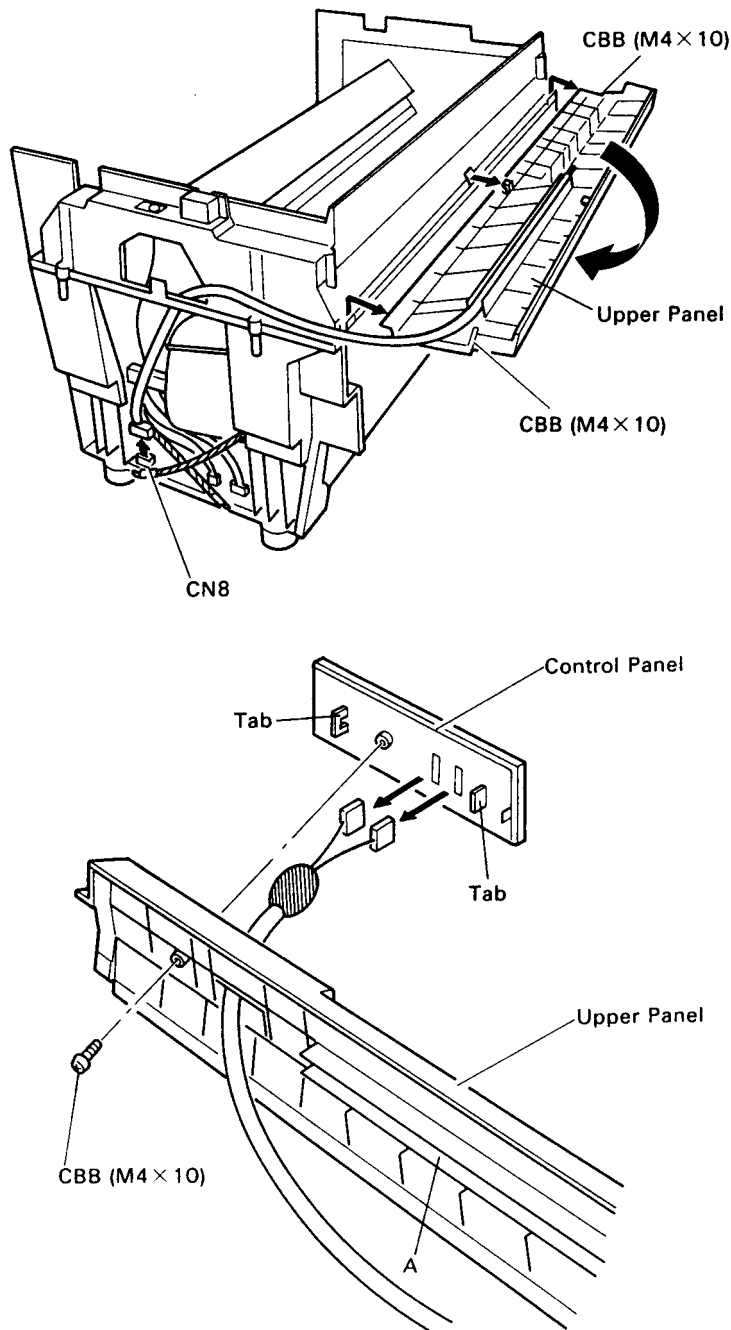

Figure 3-25. Control Panel Unit Removal

#### ASSEMBLY POINT:

- . Fit the control panel cable to the guide at the back of the upper panel (part A in Figure 3-25) when connecting it.

### 3.2.5 Interlock Switch Removal

- Step 1:** Remove the upper housing. (Refer to section 3.2.3.4.).
- Step 2:** Disconnect the interlock unit cable connector from the driver board.
- Step 3:** Remove the CBB(M4 X 10) screw fixing the interlock switch set to the lower housing, and take out the switch set from the inner space.

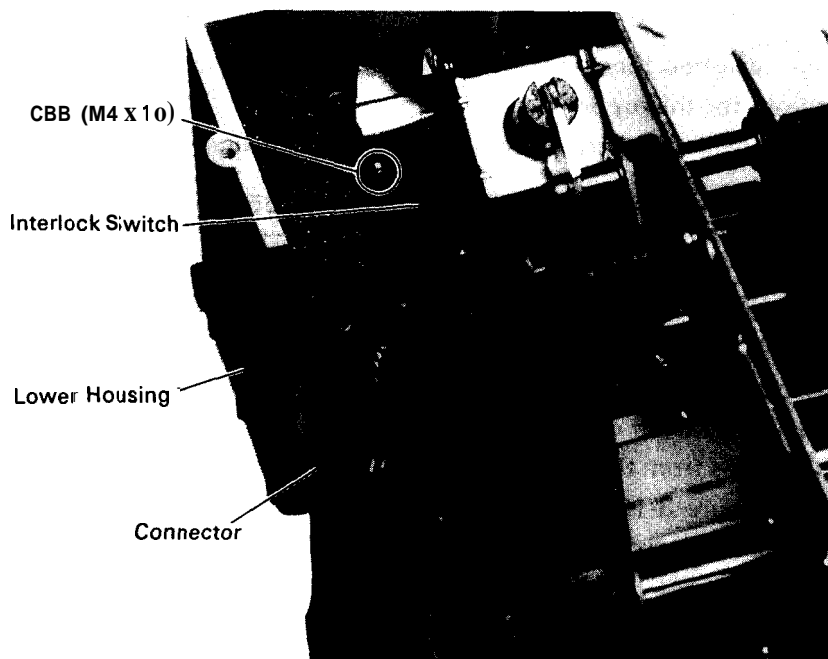

Figure 3-26. Interlock Switch Removal

### 3.2.6 Printer Mechanism Removal

Here we will describe how to remove the printer mechanism.

#### WARNING

The printer mechanism of this unit is larger and heavier than that of previous models. Therefore, when removing it, you must be very careful.

When raising or lowering the printer mechanism, please follow the warnings below:

- Use the lifting handle designed for this unit.
- Two people are required for this operation.
- Place the unit at a low position before starting so as not to strain your waist, hands or feet.

Lift handle: #E656 Part code No. B7651 11001

- Step 1: Remove the interlock switch. (Refer to section 3.2.5.)
- Step 2: Remove the three CBS(O)(M4 X 8) screws fixing the right and left ground lines (green) to the base plate. (Two at the left, one at the right, See Figure 3-1 9.)
- Step 3: Disconnect the cables from connectors CN7 and CN 10 at the left side of the main board. Disconnect the cables from the driver board (A, B in Figure 3- 19.) at the left side of the printer mechanism (See Figure 3-1 9.)
- Step 4: Remove the four screws fixing the printer mechanism to the lower housing.

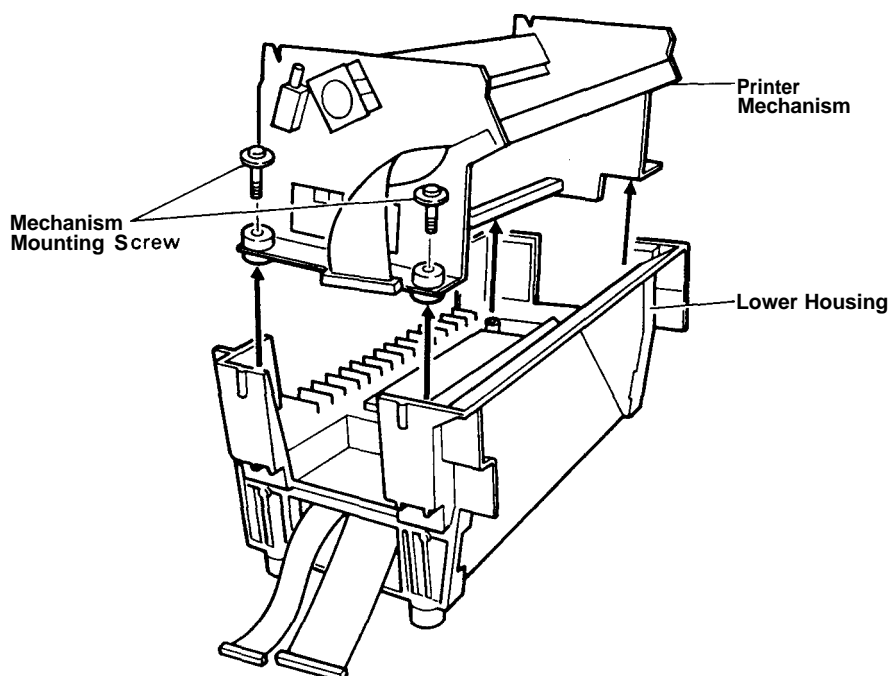

Figure 3-27. Printer Mechanism Removal

Step 5: Mount the lifting handle from inside, running it through the two holes on both side frames of the printer mechanism. Slowly raise the printer mechanism using the handle and take it out of the lower housing.

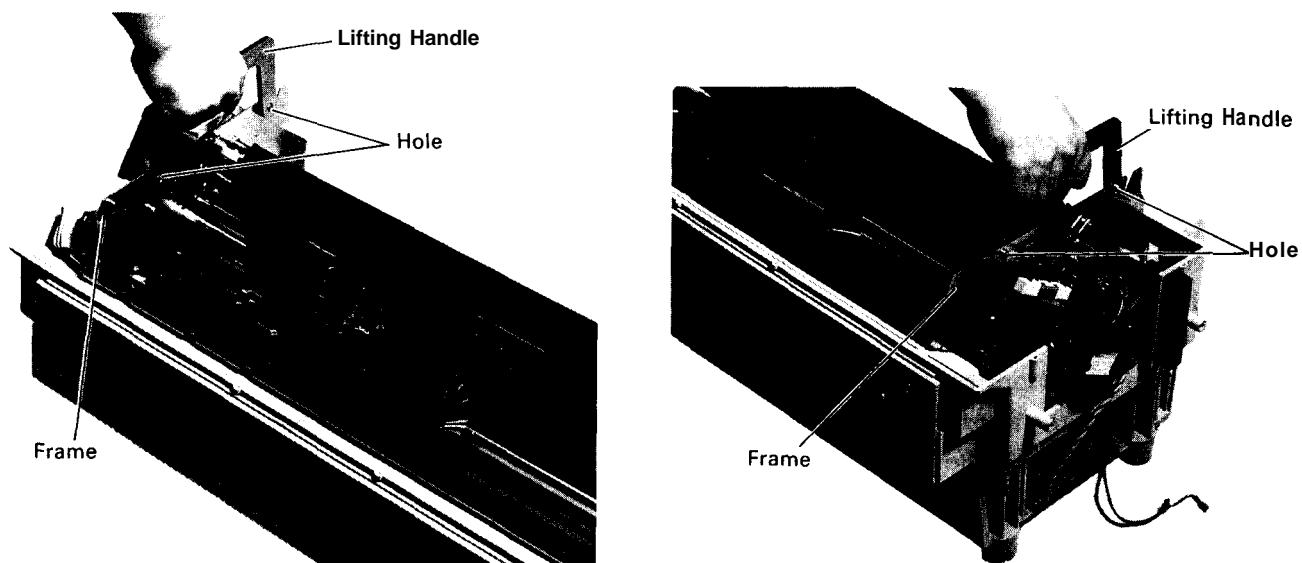

Figure 3-28. Raising the Printer Mechanism

**ASSEMBLY POINT:**

- When reattaching the printer mechanism, the cables should be routed as shown in Figure 3-19, being sure that they are not placed between the printer mechanism and the lower case (See Figure 3-1 9.)

**ADJUSTMENT REQUIRED**

The following must be performed when the printer mechanism unit is replaced:

- Bi-directional Printing Adjustment (See section 4.3)

REV.-A

### 3.2.7 Printer Mechanism Quick Component Removal

This section describes removal of those printer mechanism components that can be removed without having to remove the printer mechanism unit.

#### 3.2.7.1 Paper Width Sensor Removal

If the paper width sensor is not installed at the right position or if the detector section gets dirty, its performance will deteriorate. Therefore, the paper width sensor is supplied with the ribbon mask assembly as a unit.

For ribbon mask assembly removal, refer to Section 3.2.1 "Printhead Exchange."

#### 3.2.7.2 Paper Guide Support Plate Removal

The paper guide support plate in this printer can be removed separately so that problems such as paper jams and labels getting stuck to the lower portion of the printer can be easily fixed.

Step 1: Open the front cover.

Step 2: Remove the two CP (SP) (M3 X 6) screws securing the paper guide support plate to the printer mechanism, while holding it.

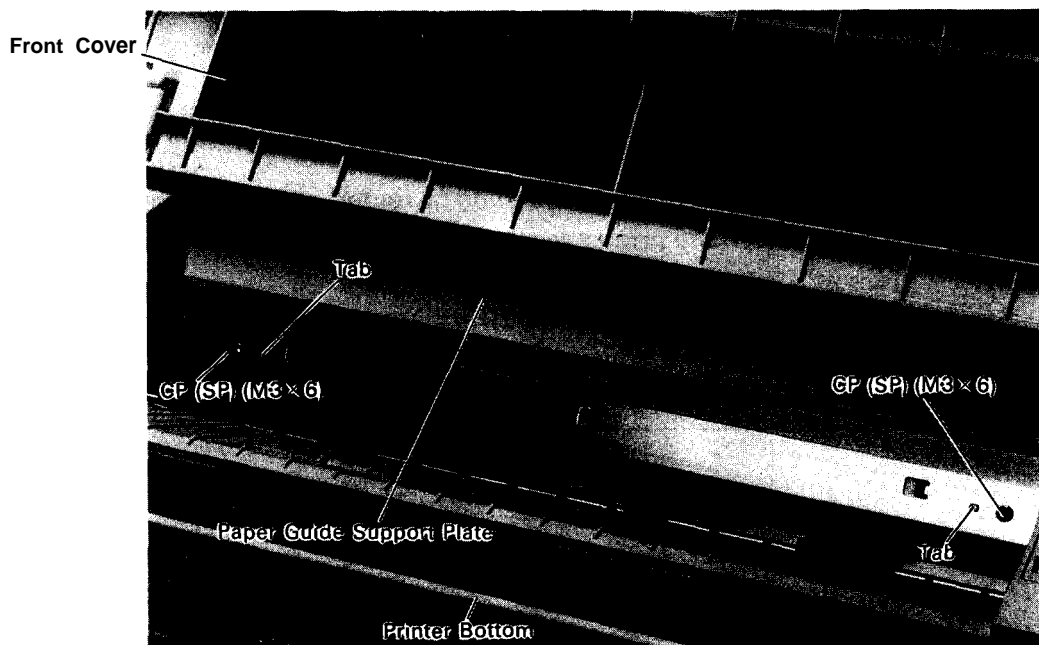

Figure 3-29. Paper Guide Support Plate Removal

#### ASSEMBLY POINT:

When reattaching the paper guide support plate, mate the holes next to the left and right screw holes with the tabs on the printer mechanism.



### 3.2.7.3 Carriage Home Position Sensor Removal

- Step 1: Remove the upper housing. (Refer to section 3.2.3.4.)
- Step 2: Disconnect the carriage home position sensor cable from the connector on the head cable board.
- Step 3: Remove the screw securing the carriage home position sensor, then remove the sensor.

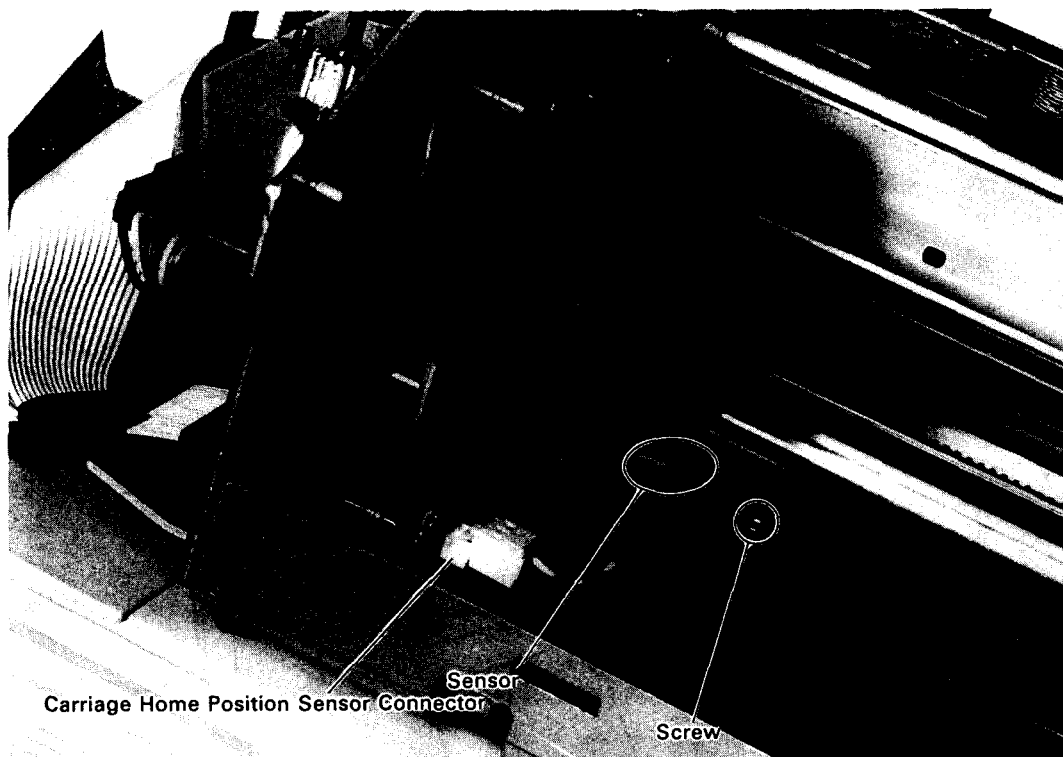

Figure 3-30. Carriage Home Position Sensor Removal

#### ASSEMBLY POINT:

- When reattaching the carriage home position sensor, mate the screw and tab holes with the screw hole and tab on the mechanism unit.

REV.-A

### 3.2.7.4 External Fan Unit Removal

- Step 1:** Remove the upper housing. (Refer to section 3.2.3.4.)
- Step 2:** Disconnect the fan unit cable from the connector on the terminal board. (See APPENDIX, Figure A-2.)
- Step 3:** Remove the three CS (M3 X 30) screws fixing the fan to the fan cover.
- Step 4:** Remove the CB(SP)(M4 X 6) screw fixing the fan cover to the left frame of the printer mechanism.

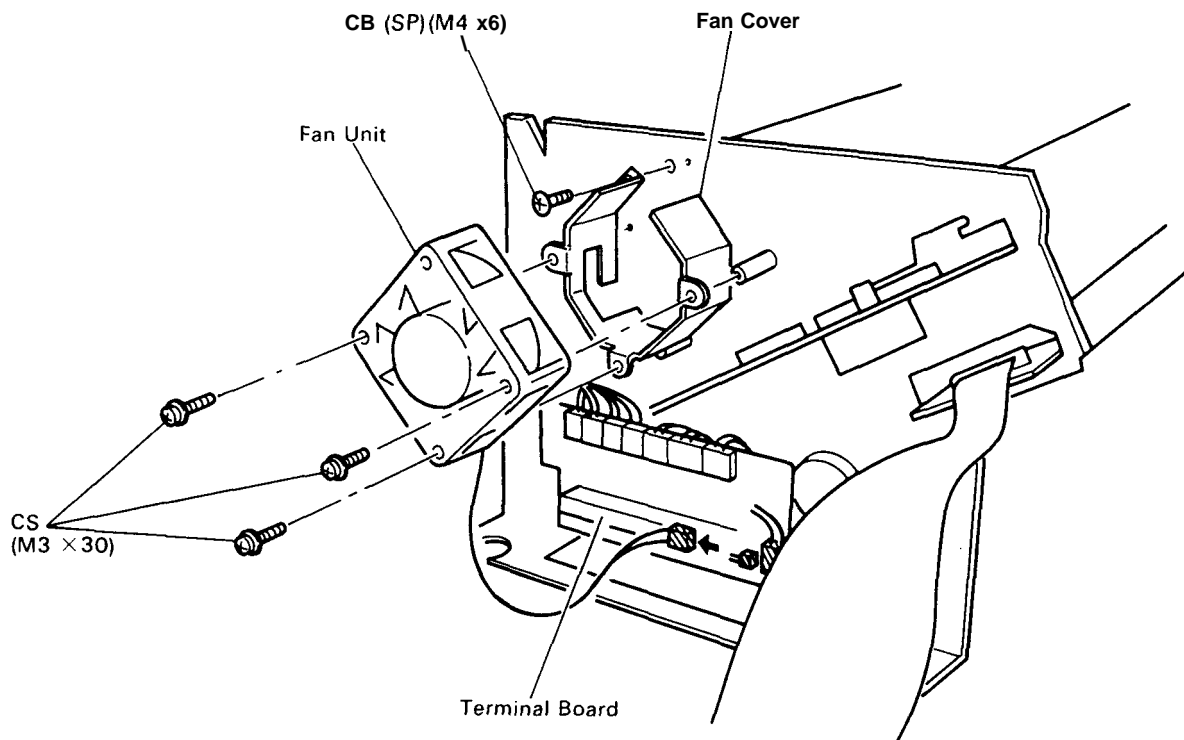

Figure 3-31. External Fan Unit Removal

#### ASSEMBLY POINT:

- When connecting the cable which was disconnected in Step 2 above to the connector on the terminal board, refer to Figure A-2 "Terminal Board Cable Connections."
- The outlet of the fan must face the inside of the mechanism. Therefore, attach the fan so that the label on the fan is on the frame side.

### 3.2.7.5 Loading Solenoid Removal

- Step 1:** Remove the upper housing. (Refer to section 3.2.3.4.)
- Step 2:** Disconnect the loading solenoid cable (black) from the terminal board. (See APPENDIX, Figure A-2.)
- Step 3:** Remove the two CP (SP) (M3 X 6) screws securing the loading solenoid to the left frame, while holding the solenoid
- Step 4:** Remove the loading solenoid and iron core.

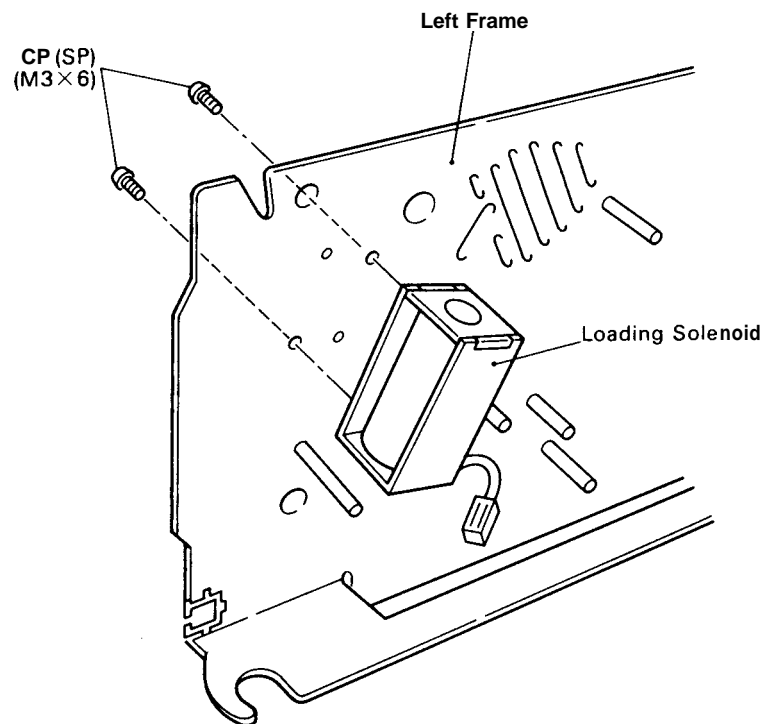

Figure 3-32. Loading Solenoid Removal

#### ASSEMBLY POINT:

- When connecting the cable which was disconnected in Step 2 above to the connector on the terminal board, refer to Figure A-2 "Terminal Board Cable Connections."

REV.-A

### 3.2.7.6 Ribbon Feed Motor and Tractor Select Sensor Removal

#### R/F Change Lever Unit Removal

- Step 1: Remove the external fan unit. (Refer to section 3.2.7.4.)
- Step 2: Disconnect the ribbon feed motor and the tractor select sensor cables from the connectors (white and yellow) on the terminal board. (See APPENDIX, Figure A-2.)
- Step 3: Remove the carriage damper (left), and remove the ribbon feed gear cover, then remove the ribbon feed gear.

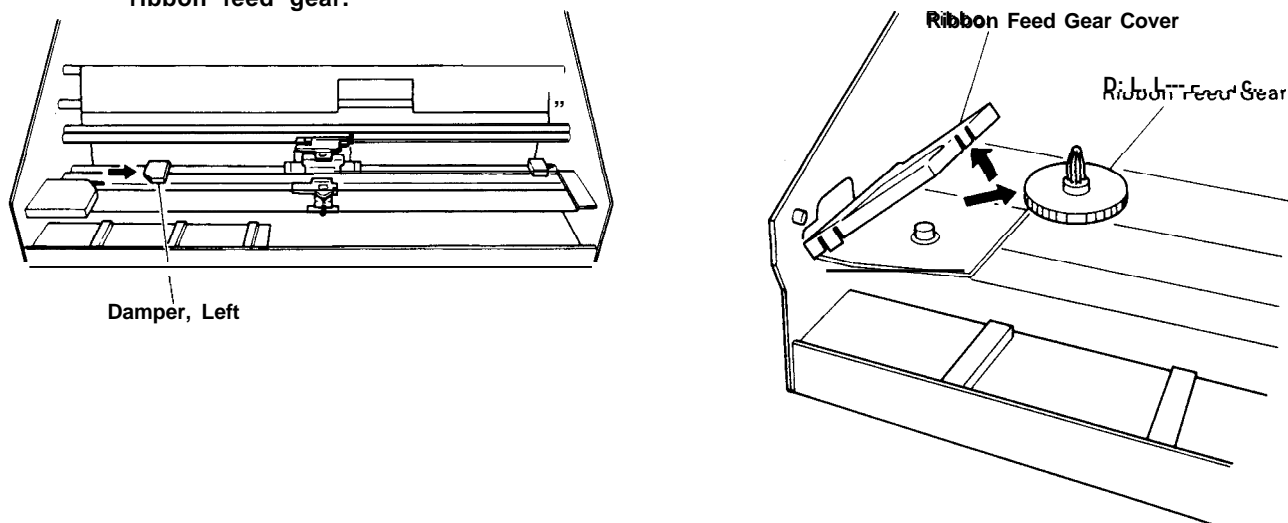

Figure 3-33. Damper, Left/Ribbon Feed Gear Removal

- Step 4: Remove two CPS (P) (M3 X 6) screws securing the R/F change lever unit, then remove the R/F change lever unit.

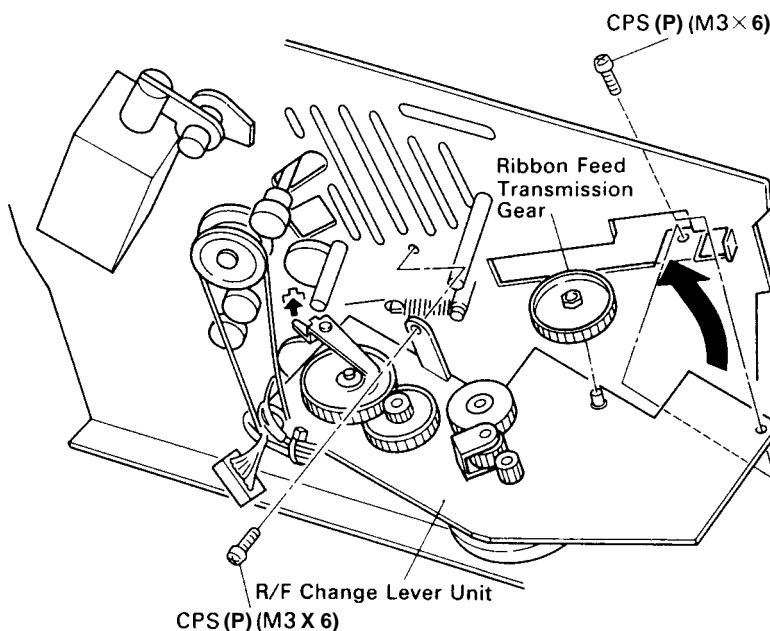

Figure 3-34. R/F Change Lever Unit Removal

#### ASSEMBLY POINT:

- When attaching the R/F change lever unit, join the tip of the tractor select lever and the tractor select gear holder correctly. (See CHAPTER 2, Figure 2-1 1.)

### R/F Change Lever Unit Disassembly

- Step 5:** Remove the two CP (PS) (M3 X 6) screws securing the ribbon feed motor to the R/F change lever unit, then remove the ribbon feed motor.  
Disconnect the cable from the connector (black) on the ribbon feed motor.
- Step 6:** Remove the E ring (3) securing the tractor select lever, then remove the tractor change lever. Remove the E ring (3) securing the tractor select cam, then remove the tractor select cam.
- Step 7:** Remove the CP (S) (M2 X 10) screw securing the tractor select sensor, then remove the tractor select sensor.
- Step 8:** Using nippers, cut the wire band fixing the ribbon feed motor and tractor select sensor cables to the R/F change lever unit

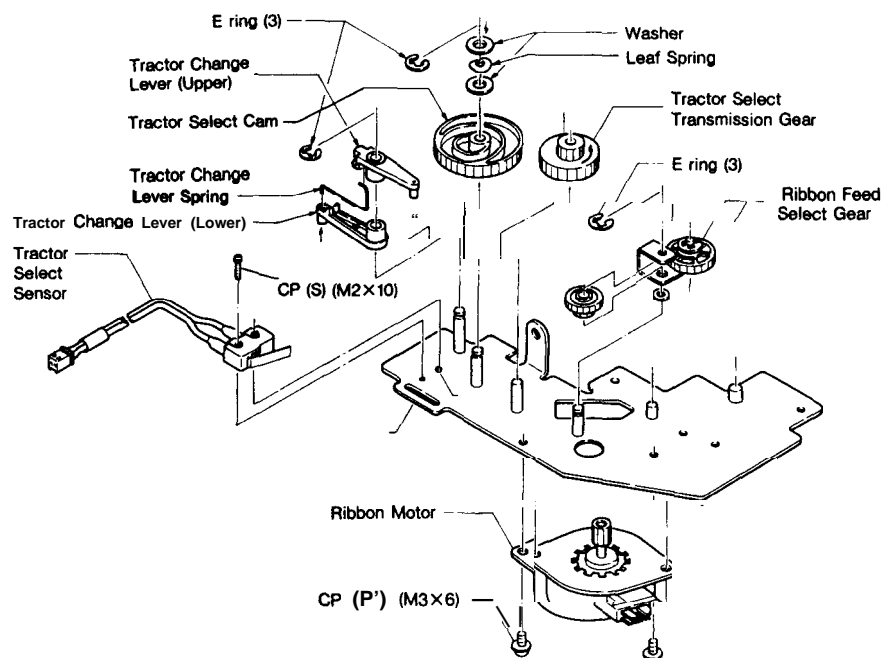

Figure 3-35. R/F Change Lever Unit Disassembly

### ASSEMBLY POINT:

- When connecting the cables which were disconnected in Step 2 above to the connector on the terminal board, refer to Figure A-2 "Terminal Board Cable Connections."
- When attaching the tractor select lever to the tractor select cam, carefully observe the mounting position shown in the Figure below

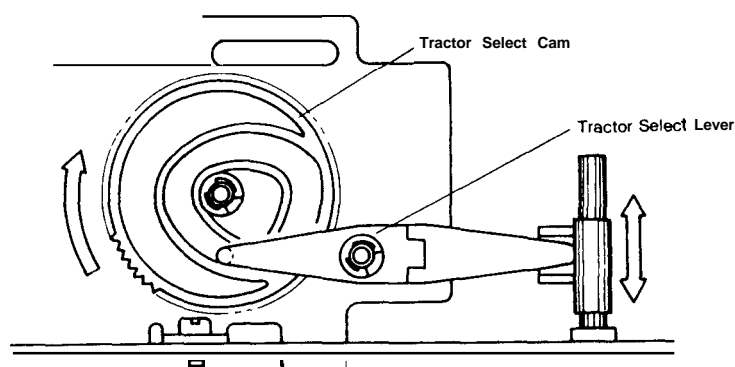

Figure 3-36. Tractor Select Lever Mounting Position

REV.-A

### 3.2.7.7 Upper Paper End Sensor Removal

- Step 1: Remove the loading solenoid. (Refer to section 3.2.7.5.)
- Step 2: Remove the external fan unit. (Refer to section 3.2.7.4.)
- Step 3: Unhook the upper paper end sensor cable from the wire saddle, then disconnect the cable from the terminal board. (See APPENDIX, Figure A-2.)
- Step 4: Remove the paper bail spring at the left frame side.
- Step 5: Remove the paper bail gear. Remove the gear by pulling it leftward while lifting the clip section with tweezers.
- Step 6: Remove the E ring (6) securing the paper bail lever to the left side of the shaft, and remove the paper bail lever and shaft holder.

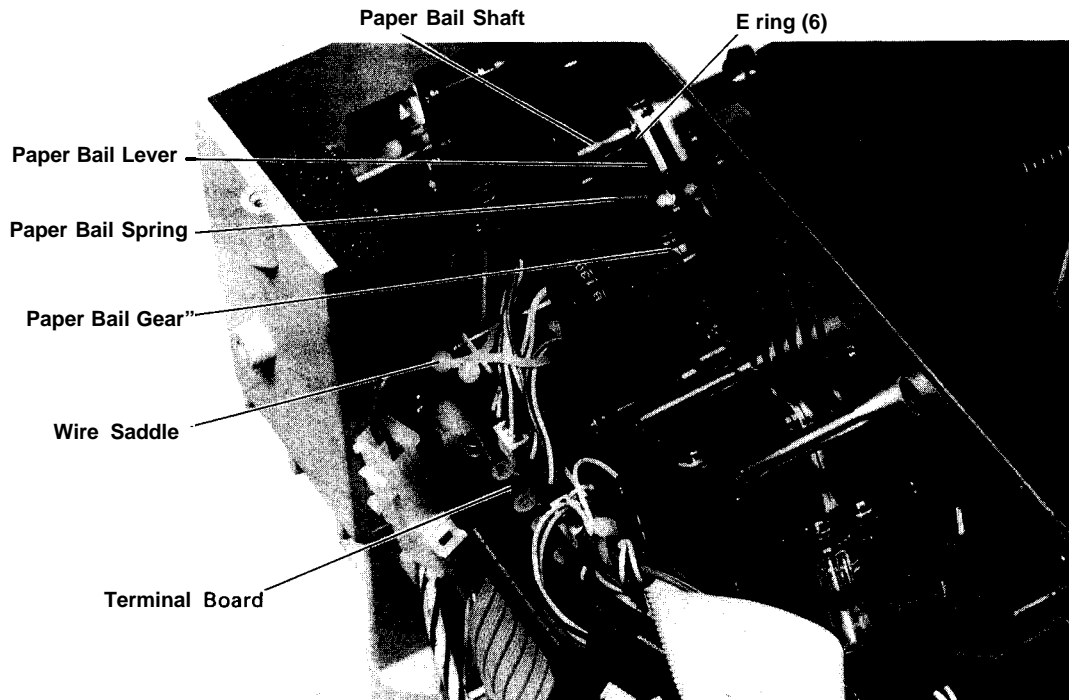
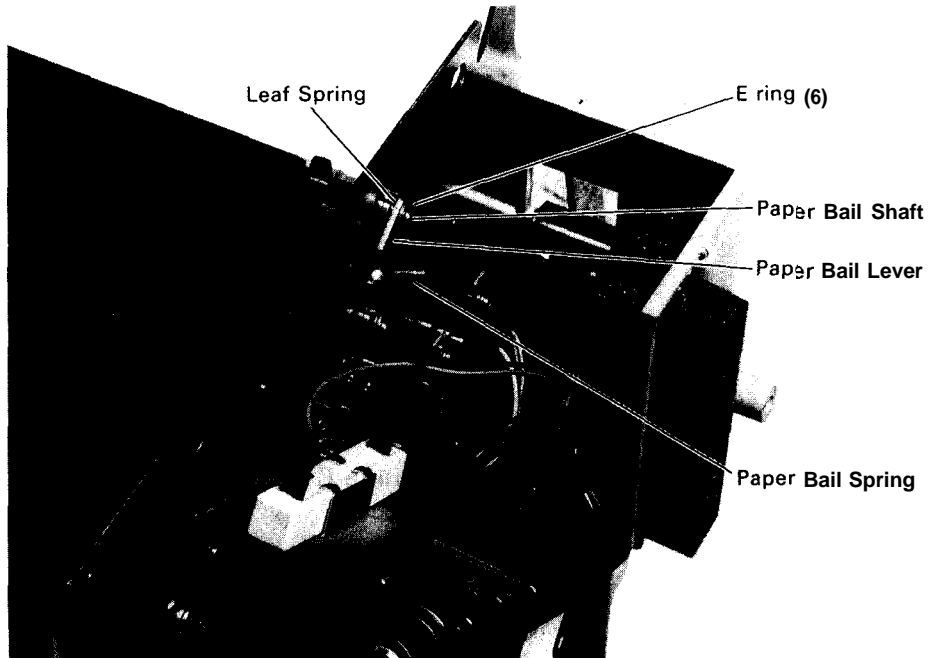

Figure 3-37. Paper Bail Removal (Left)

**Step 7:** Remove the paper bail spring at the right frame side.

**Step 8:** Remove the E ring (6) securing the paper bail lever to the right side of the shaft, and remove the paper bail lever, leaf spring, and shaft holder.



**Figure 3-38. Paper Bail Removal (Right)**

**Step 9:** Pull out the paper bail. When pulling out the tension roller shaft, shift it leftward and pull out the right side first, then pull out the left side

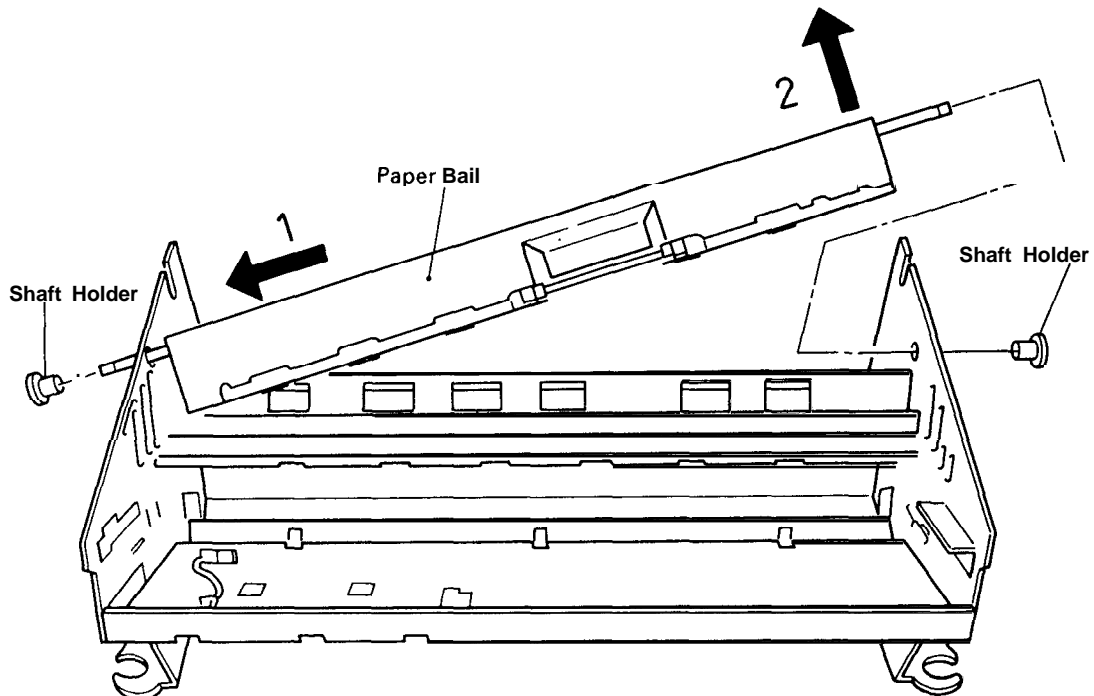

**Figure 3-39. Paper Bail Removal**

REV.-A

Step 10: Remove the two CBS (0) (M4 X 6) screws securing the upper paper guide, then remove the upper paper guide.

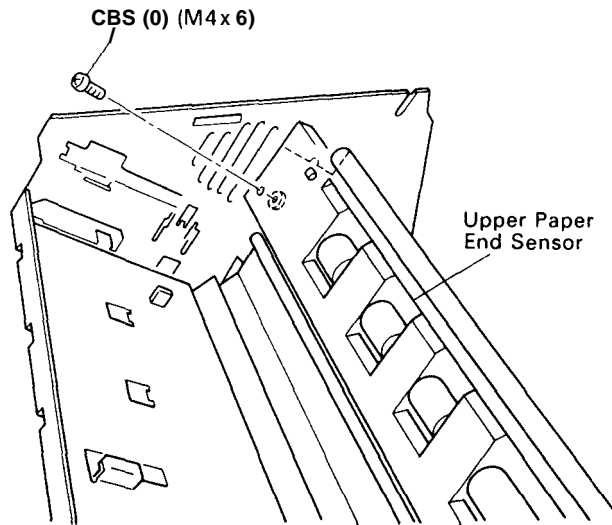

Figure 3-40. Upper Paper Guide Removal

Step 11: Remove the two CP(PS)(M3 X 6) screws securing the upper paper end sensor to the upper paper guide, then remove the upper paper end sensor.

**ASSEMBLY POINTS:**

- When connecting the cable which was disconnected in Step 3 above to the connector on the terminal board, refer to Figure A-2 "Terminal Board Cable Connections."
- When attaching the leaf spring to the tension roller shaft, set the spring so that the bulge in the spring is at the shaft holder side.
- When attaching the upper paper guide, tighten the screws while pulling the paper guide downward and leftward. (See Figure 3-40.)
- When attaching the upper paper guide, withdraw the upper paper end sensor cable from the hole in the left frame.

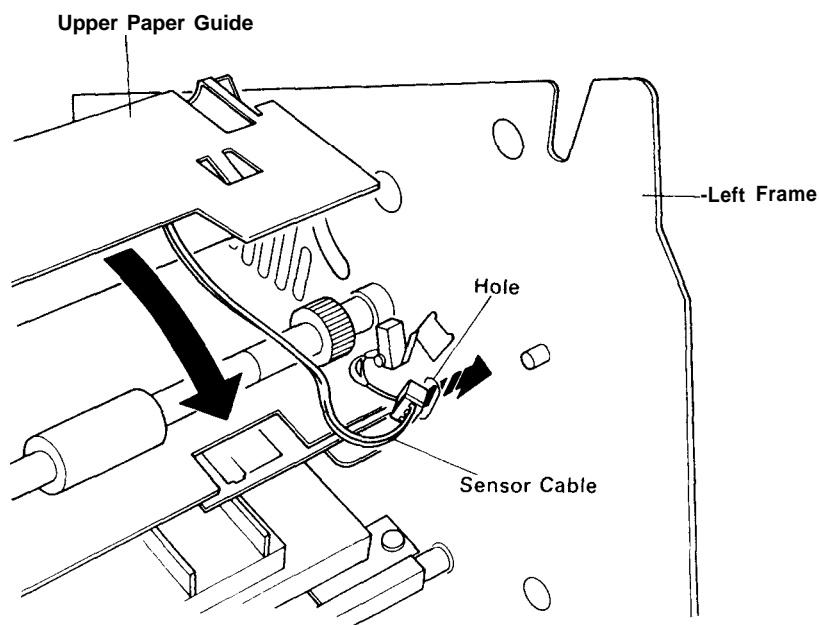

Figure 3-41. Upper Paper Guide Assembly



### 3.2.7.8 Pull Tractor Sensor Removal

- Step 1:** Remove the upper paper guide. (Refer to section 3.2.7.7.)
- Step 2:** Remove the two CP (P) (M3 X 6) screws securing the terminal board to the printer mechanism, then disconnect all the cables connecting the terminal board.
- Step 3:** Remove the paper feed timing belt. It can be removed easily by removing it while pushing on the tension pulley.
- Step 4:** Remove the tension roller gear on the left side of the tension roller shaft. Remove the gear by pulling it leftward while lifting the clip section with tweezers.

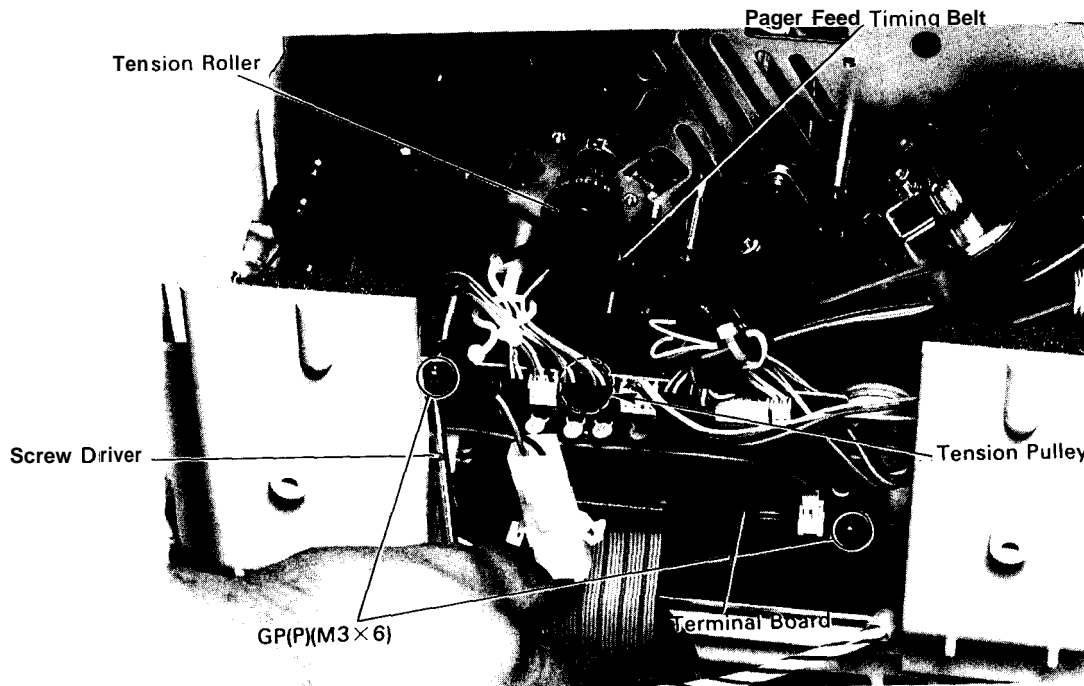

Figure 3-42. Terminal Board Removal

- Step 5:** Remove the E ring (6) on the right side of the tension roller shaft, and pull out the shaft holder.
- Step 6:** Remove the E ring (6) on the left side of the tension roller shaft, then remove the plain washer, leaf spring, and shaft holder the same way as in Step 5.

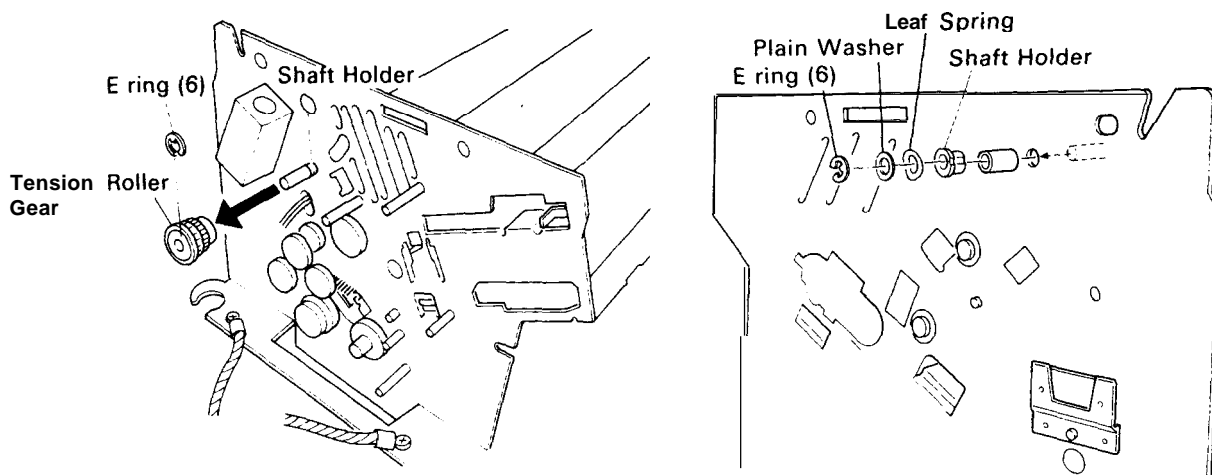

Figure 3-43. Tension Roller Shaft Removal-1

Step 7: pull out the tension roller shaft. When pulling it out, shift it rightward and pull out the left side first, then pull out the right side.

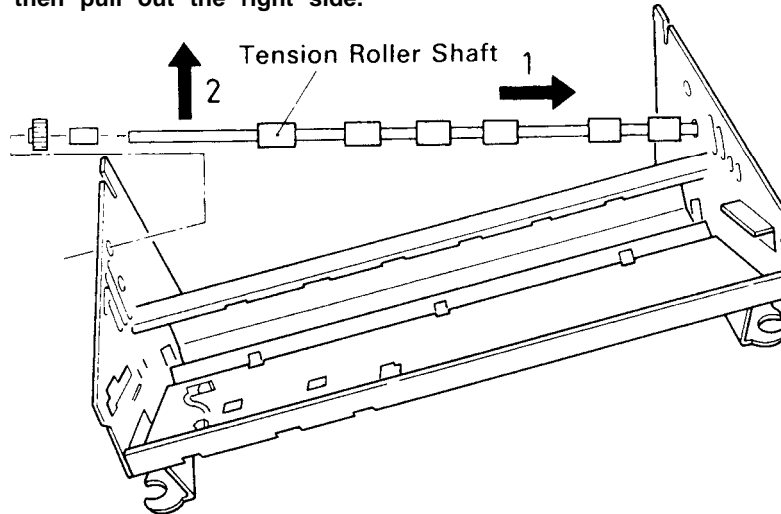

Figure 3-44. Tension Roller Shaft Removal-2

Step 8: Remove the CPS (S) (M2 X 10) screw securing the pull tractor sensor to the left side frame, and remove the sensor.

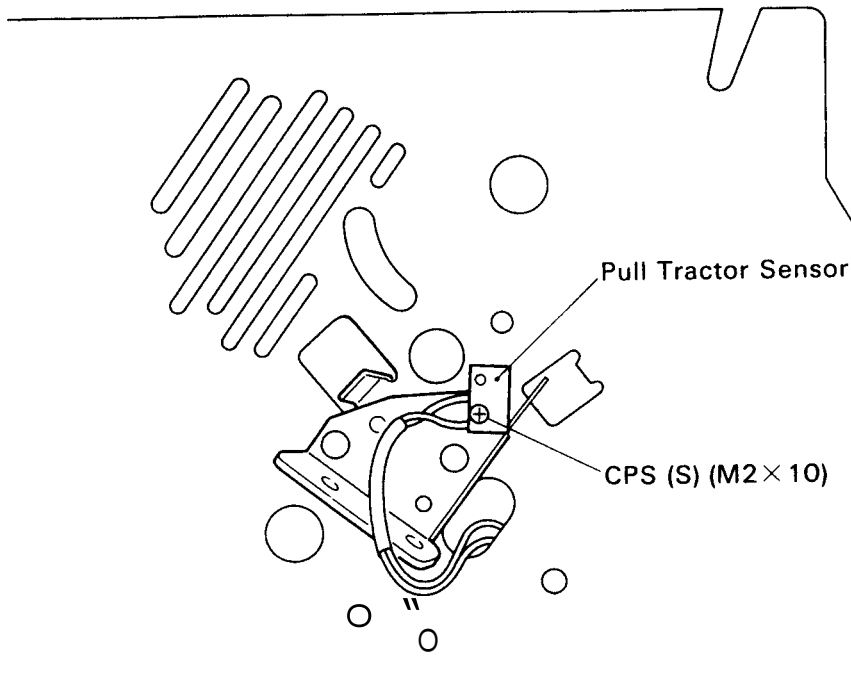

Figure 3-45. Pull Tractor Sensor Removal

**ASSEMBLY POINTS:**

- When attaching the leaf spring to the tension roller shaft, set the spring so that the bulge in the spring is at the shaft holder side.
- When connecting the cables which were disconnected in Step 2 above to the connector on the terminal board, refer to Figure A-2 "Terminal Board Cable Connections."

### 3.2.7.9 Platen Removal

**Step 1:** Remove the tension roller shaft. (Refer to section 3.2.7.8.)

**Step 2:** Remove the four CPS(PS)(M4 X 8) screws securing the platen to the platenholder and remove the platen.

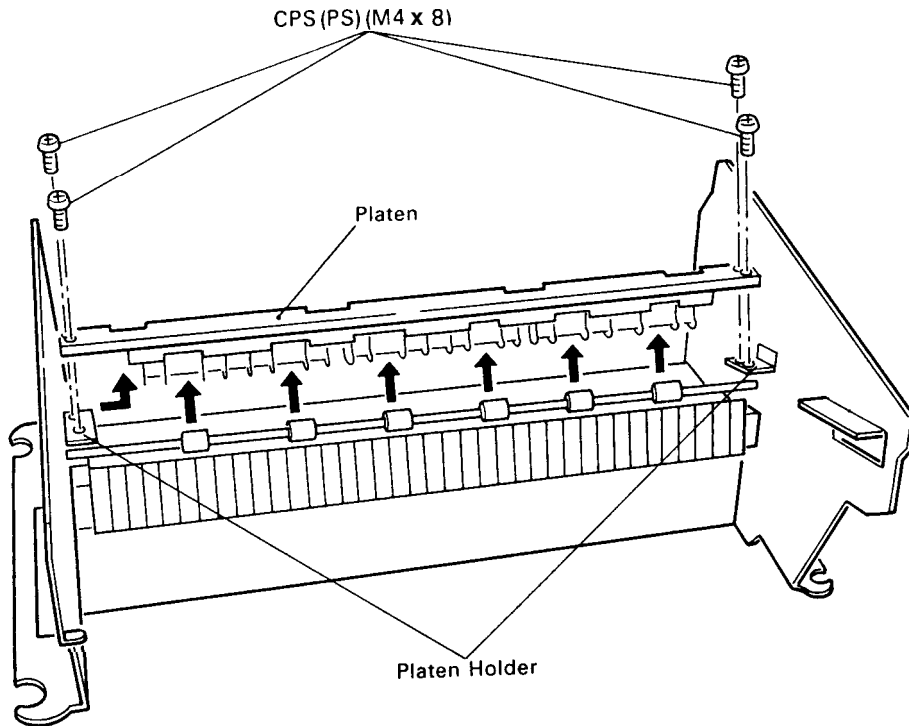

Figure 3-46. Platen Removal

#### ASSEMBLY POINTS:

- . When attaching the platen, tighten the screws while pulling the platen downward and leftward. (See Figure 3-46.)
- When connecting the cables which were disconnected in Step 2 of Section 3.2.7.8 to the connector on the terminal board, refer to Figure A-2 "Terminal Board Cable Connections."

#### ADJUSTMENT REQUIRED

The following adjustments must be performed when the platen is removed:

- . Bi-directional Printing Adjustment (See section 4.3.)
  - Parallelism Adjustment (See section 4.4.)
  - Mechanism Adjustment Value Measurement (See section 4.6.)

### 3.2.8 Printer Mechanism Component Removal

This section describes printer mechanism unit disassembly. The description starts by assuming that the printer mechanism unit has been removed from the printer. Therefore, the first step, "Remove the printer mechanism unit.", is omitted from the beginning of each subsection.

#### 3.2.8.1 Platen Gap Sensor and Platen Gap Adjustment Motor Removal

**WARNING**

- When attaching or removing the platen gap sensor, be careful not to bend the detection board of the platen gap adjustment motor.

- Step 1:** Disconnect all the cables connecting the terminal board, then remove the two CP (P) (M3 X 6) screws securing the terminal board to the printer mechanism (See Figure 3-42.)
- Step 2:** Remove the CPS (P) (M3 X 6) screw securing the platen gap sensor, and remove the platen gap sensor by pulling it toward you.
- Step 3:** Remove the two CP (PS) (M3 X 6) screws securing the platen gap adjustment motor, and remove it.

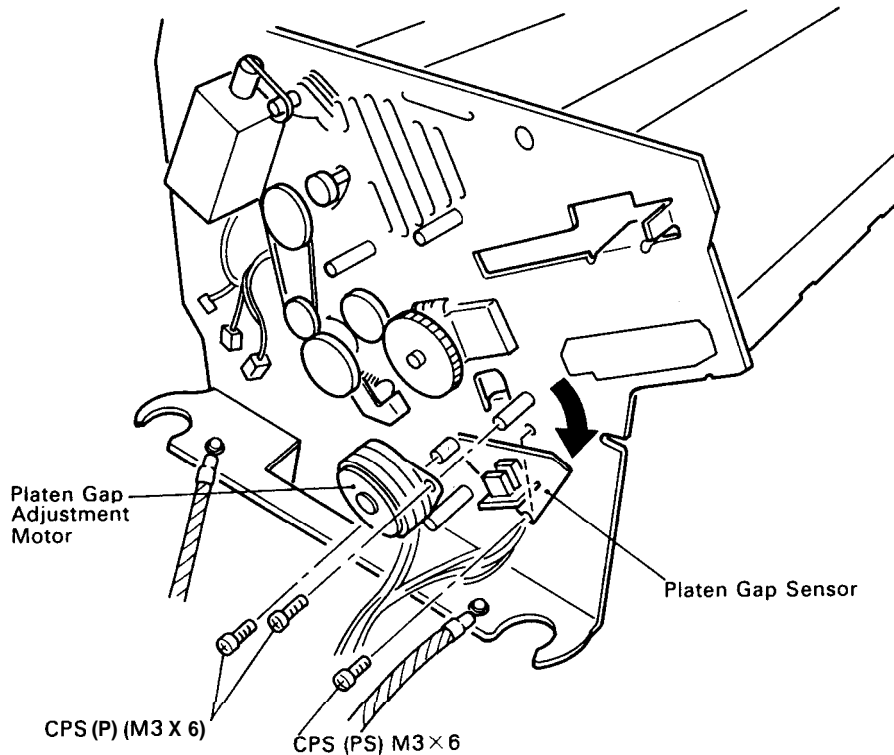

Figure 3-47. Platen Gap Sensor and Platen Gap Adjustment Motor Removal

**ASSEMBLY POINTS:**

- When connecting the cables which were disconnected in Step 1 above to the connector on the terminal board, refer to Figure A-2 "Terminal Board Cable Connections."
- When attaching the platen gap adjustment motor, adjust the backlash between it and the platen gap adjustment transmission gear to between 0.05 and 0.15 mm. (Almost no backlash)
- When attaching the platen gap sensor, join portion A in Figure 3-48 correctly and match the screw at portion B to the frame hole, so that the platen gap sensor does not float.

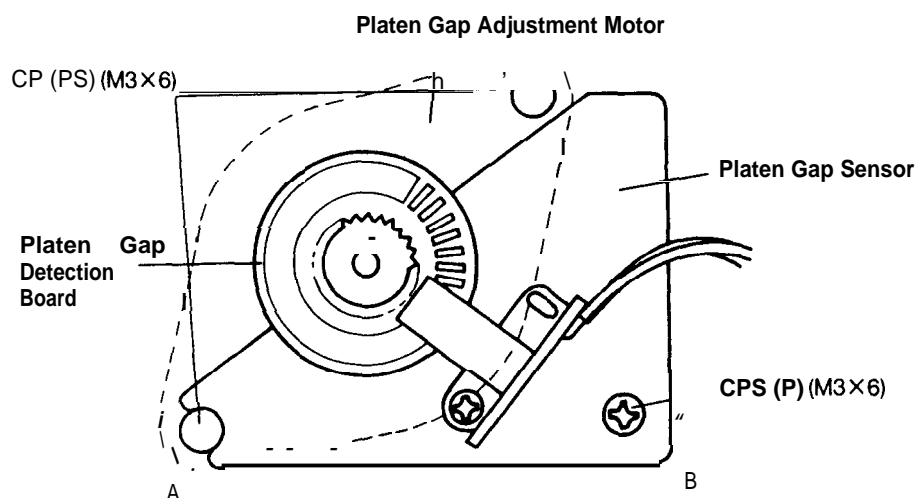

Figure 3-48. Platen Gap Sensor Assembly Point

**ADJUSTMENT REQUIRED**

The following adjustments must be performed when the platen gap sensor and platen gap adjustment motor are replaced:

- . Bi-directional Printing Adjustment (See section 4.3.)
- . Parallelism Adjustment (See section 4.4.)
- Mechanism Adjustment Value Measurement (See section 4.6.)

REV.-A

### 3.2.8.2 Paper Feed Motor Removal

- Step 1:** Disconnect all the cables connecting the terminal board, then remove the two CP (P) (M3 X 6) screws securing the terminal board to the printer mechanism (See Figure 3-42.)
- Step 2:** Slowly turn the printer mechanism down towards you, then unhook the paper feed motor cable (red, 6 pin connector) from the two wire saddles and the wire holder.

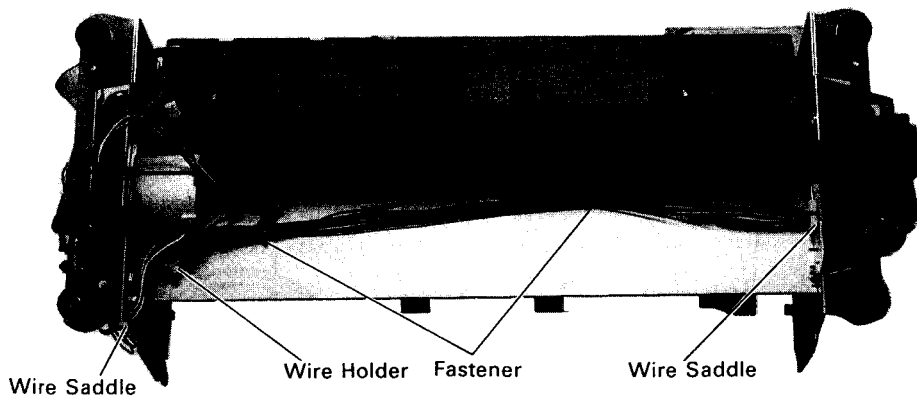

Figure 3-49. Wire Saddle and Holder

- Step 3:** Remove the three CP (PS) (M4 X 8) screws securing the paper feed motor to the left frame.
- Step 4:** Remove the paper feed motor from the inside of the left frame.

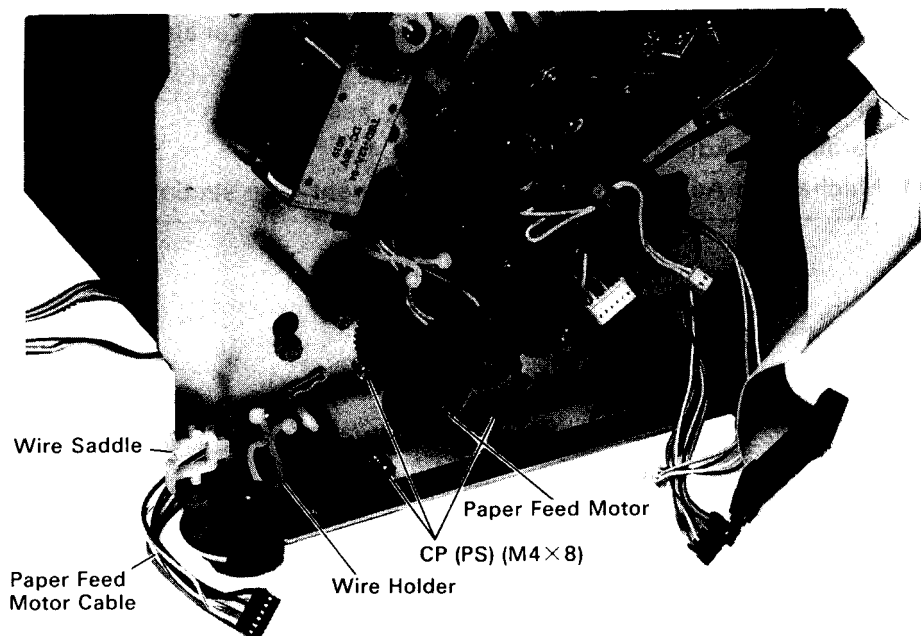
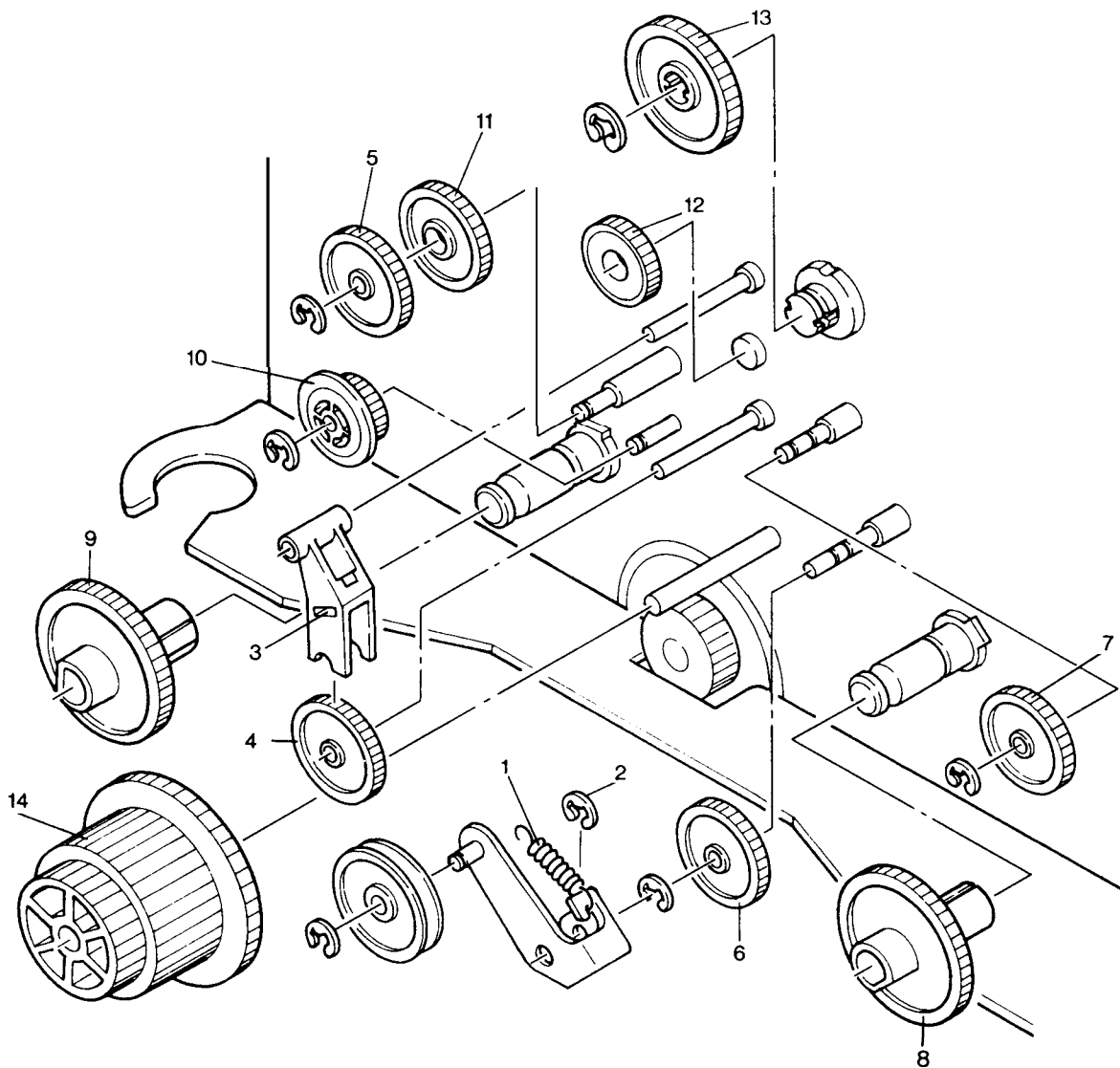

Figure 3-50. Paper Feed Motor Removal

**ASSEMBLY POINTS:**

- When connecting the cables which were disconnected in Step 1 above to the connector on the terminal board, refer to Figure A-2 "Terminal Board Cable Connections."
- When removing the gears of the paper feed mechanism, refer to Figure 3-50. The numbers in the figure indicate the order of disassembly. When reassembling the gears, assemble them in the reverse order.

**Figure 3-51. Left Frame Gear Connection**

### 3.2.8.3 Front Tractor Unit Removal

This section describes the front tractor unit removal. Remove the front tractor unit before removing the front paper end sensor.

- Step 1: Disconnect all the cables connecting the terminal board, then remove the two CP (P) (M3 X 6) screws securing the terminal board to the printer mechanism (See Figure 3-42.)
- Step 2: Turn the printer mechanism and lay it on its back, then loosen the hexagonal nuts securing the shaft at the front side of the front tractor unit to the left and right frames.
- Step 3: Remove the E ring (6) securing the shaft at the back side of the front tractor unit to the left frame.
- Step 4: Remove the front tractor gear. (Gear #8 in Figure 3-50.)

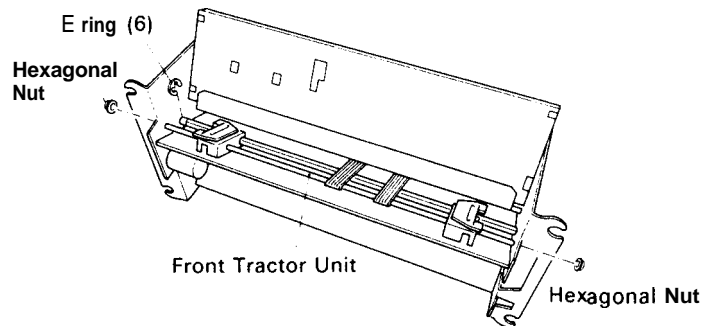

Figure 3-52. Front Tractor Unit Removal-1

- Step 5: Rotate the printer mechanism down towards you, then unhook the front paper end sensor cable (white, 3 pin connector) from the two wire saddles and the wire holder. (See Figure 3-49.)
- Step 6: Raise the printer mechanism, then remove the front tractor unit. First shift the whole tractor unit leftward, remove the right side of the shaft by pulling it frontward, then remove the left side of the shaft. Withdraw the front paper end sensor cable from the gap in the lower frame.

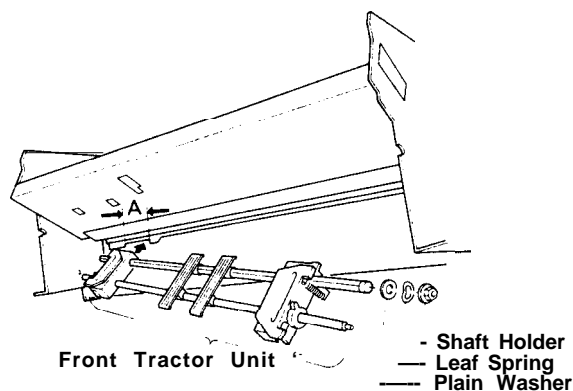

Figure 3-53. Front Tractor Unit Removal-2

#### ASSEMBLY POINTS:

- When reattaching the front tractor unit, attach the left tractor subassembly within the range A shown in Figure 3-53.
- When attaching the leaf spring to the tension roller shaft, set the spring so that the bulge in the spring is at the shaft holder side.
- When attaching the shaft holder to the frame, set the holder from the inside.
- When connecting the cables which were disconnected in Step 1 above to the connector on the terminal board, refer to Figure A-2 "Terminal Board Cable Connections."



### 3.2.8.4 Rear Tractor Unit Removal

This section describes the rear tractor unit removal. Remove the rear tractor unit before removing the rear paper end sensor.

- Step 1: Disconnect all the cables connecting the terminal board, then remove the two CP (P) (M3 X 6) screws securing the terminal board to the printer mechanism (See Figure 3-42.)
- Step 2: Loosen the hexagonal nuts securing the shaft at the front side of the rear tractor unit to the left and right frames.
- Step 3: Remove the E ring (6) securing the shaft at the back side of the rear tractor unit to the left frame.
- Step 4: Remove the rear tractor gear. (Refer to gear #9 in Figure 3-50.)

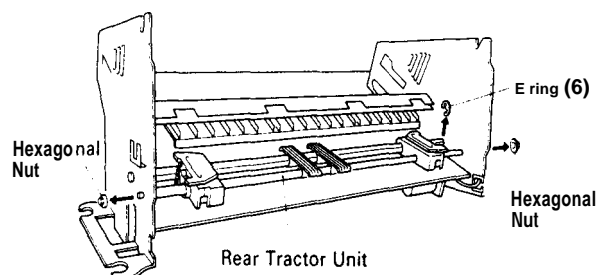

Figure 3-54. Rear Tractor Unit Removal-1

- Step 5: Rotate the printer mechanism and lay it on its back, then unhook the rear paper end sensor cable (black, 3 pin connector) from the two wire saddles and the wire holder. (See Figure 3-49.)
- Step 6: Raise the printer mechanism, then remove the rear tractor unit. First shift the whole tractor unit rightward, remove the left side of the shaft by pulling it toward you, then remove the right side of the shaft. Withdraw the front paper end sensor cable from the gap in the lower frame.

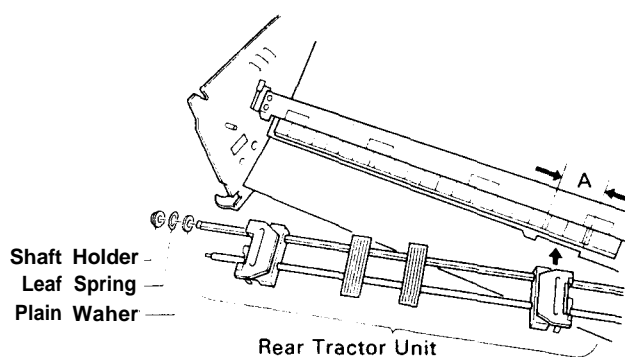

Figure 3-55. Rear Tractor Unit Removal-2

#### ASSEMBLY POINTS:

- When reattaching the front tractor unit, attach the left tractor subassembly within the range A shown in Figure 3-53.
- When attaching the leaf spring to the tension roller shaft, set the spring so that the bulge in the spring is at the shaft holder side.
- When attaching the shaft holder to the frame, set the holder from the inside.
- When connecting the cables which were disconnected in Step 1 above to the connector on the terminal board, refer to Figure A-2 "Terminal Board Cable Connections."

REV.-A

### 3.2.9.13 Carriage Motor Unit Removal

This section describes the carriage motor unit removal, including ribbon mask holder removal

- Step 1: Disconnect all the cables connecting the terminal board, then remove the two CP (P) (M3 X 6) screws securing the terminal board to the printer mechanism (See Figure 3-42.)
- Step 2: Rotate the printer mechanism and lay it on its back, then unhook all the cables going to the right frame from the two fasteners, two wire saddles, and the wire holder. (See Figure 3-49.)
- Step 3: Raise the printer mechanism, loosen the three CP(CS)(M4 X 8) screws securing the motor to the motor holder, then unhook the timing belt from the motor pulley.
- Step 4: Remove the three CBS (0) (M4 X 8) screws securing the carriage motor unit to the right frame, and remove the carriage motor unit.

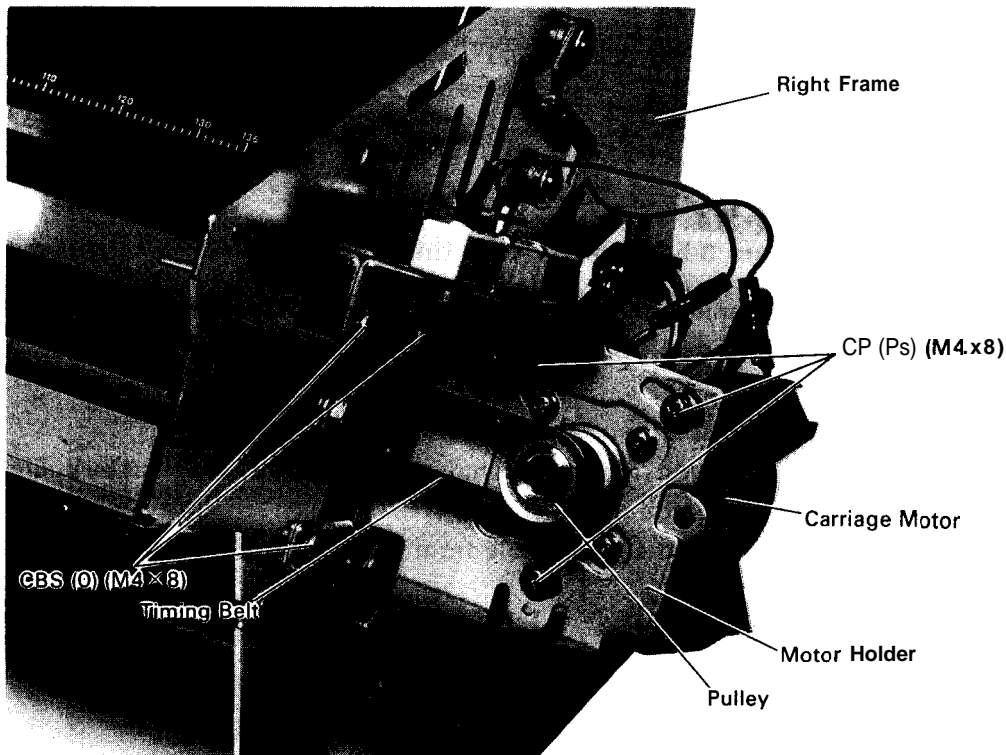

Figure 3-56. Carriage Motor Unit Removal

#### ADJUSTMENT REQUIRED

The following adjustments must be performed when the carriage unit is removed or replaced:

- Carriage Timing Belt Tension Adjustment (See section 4.5.)
- Bi-directional Printing Adjustment (See section 4.3.)

# CHAPTER 4

## ADJUSTMENT

4.1 ADJUSTMENT OVERVIEW .....	4-1
4.2 PRINTHEAD ADJUSTMENT VALUE WRITING .....	4-3
4.3 61-DIRECTIONAL PRINTING ADJUSTMENT .....	4-5
4.4 PARALLELISM ADJUSTMENT .....	4-8
4.5 TIMING BELT TENSION ADJUSTMENT .....	4-10
4.6 MECHANISM ADJUSTMENT VALUE MEASUREMENT .....	4-11

## LIST OF FIGURES

Figure 4-1.	Entering the Adjustment Mode .....	4-3
Figure 4-2.	Writing the Adjustment Value .....	4-4
Figure 4-3.	BETA Value .....	4-5
Figure 4-4.	Bi-directional Printing Adjustment .....	4-6
Figure 4-5.	Printing Pattern .....	4-7
Figure 4-6.	Parallelism Adjustment Lever .....	4-8
Figure 4-7.	Dial Gauge and Dial Gauge Base Attachment .....	4-9
Figure 4-8.	Carriage Guide Shaft Parallelism Adjustment .....	4-9
Figure 4-9.	Carriage Timing Belt Tension Adjustment .....	4-10
Figure 4-10.	Pull the Thickness Gauge .....	4-12
Figure 4-11.	Mechanism Adjustment Value Measurement .....	4-13

## LIST OF TABLES

Table 4-1.	Required Adjustments .....	4-1
Table 4-2.	Tools .....	4-2
Table 4-3.	Special Tools .....	4-2

## 4.1 ADJUSTMENT OVERVIEW

This section describes the adjustment procedures required for reassembling the DFX-8000. When disassembly or replacement is performed during maintenance or repair of the parts described in this section, the following adjustments should be performed to ensure proper operation.

Table 4-1. Required Adjustments

Disassembly/Assembly/Replacement Section No.	Adjustment Section No.
3.2.1 Printhead Exchange	4.2 PRINTHEAD ADJUSTMENT VALUE WRITING
3.2.4.2 Main Board Exchange	4.2 PRINTHEAD ADJUSTMENT VALUE WRITING 4.3 BI-DIRECTIONAL PRINTING ADJUSTMENT
3.2.6 Printer Mechanism Exchange	4.3 BI-DIRECTIONAL PRINTING ADJUSTMENT
3.2.7.9 Platen Removal	4.3 BI-DIRECTIONAL PRINTING ADJUSTMENT 4.4 PARALLELISM ADJUSTMENT 4.6 MECHANISM ADJUSTMENT VALUE MEASUREMENT
3.2.8.1 Platen Gap Sensor Exchange 3.2.8.1 Platen Gap Adjustment Motor Exchange	4.3 BI-DIRECTIONAL PRINTING ADJUSTMENT 4.4 PARALLELISM ADJUSTMENT 4.6 MECHANISM ADJUSTMENT VALUE MEASUREMENT
3.2.8.5 Carriage Motor Unit Removal	4.5 CARRIAGE TIMING BELT TENSION ADJUSTMENT 4.3 BI-DIRECTIONAL PRINTING ADJUSTMENT

REV.-A

When adjusting this printer, the following tools are required.

Table 4-2. Tools

Designation	Type	Class	Part No.
#F518 Thickness gauge set	o	A	B776702201
#E668 Tension gauge (7000 g)	o	A	B777200301
#F545 Tension gauge (200 g)	o	A	B7651 14601
#E672 Dial gauge	E	A	B7651 11401
#F541 Dial gauge base	E	A	B7651 14501

O: Commercially available tool  
 E: EPSON exclusive tool  
 A: Mandatory  
 B: Recommended

Table 4-3. Special Tools

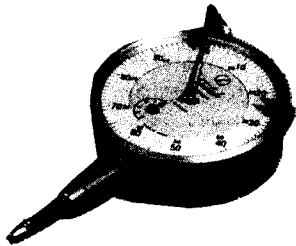
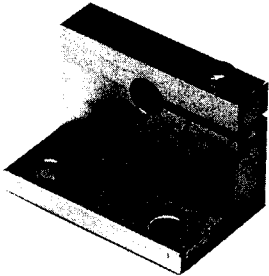
No.	Name	Figure	Description	Part No
#E672	Dial Gage		● For parallelism adjustment	B765111401
#F541	Dial Gauge Base		● For parallelism adjustment	B765114501

## 4.2 PRINTHEAD ADJUSTMENT VALUE WRITING

The purpose of this adjustment is to set the PG offset value in accordance with the nose dimension of the printhead. (For details, refer to Chapter 2.)

The offset for the nose dimension is represented by the adjustment value "ALPHA." The "ALPHA" value is stored in the memory on the main board, so the PG adjustment mechanism can read the value as needed. Be sure to perform the adjustment when required. If this adjustment is not performed correctly, the platen gap will be incorrect, the paper could be caught by a head pin, or, in the worst case, a head pin could break.

**NOTE:** The printhead adjustment value is written on the front of the head unit (refer to Figure 4-2). After the printhead is attached, the value cannot be seen. Be sure to write down the value before attaching the printhead.

- Step 1:** Connect the AC cable. Mount the ribbon cassette, and load paper into the front tractor.
- Step 2:** Turn the printer power on while pressing the LINE FEED, MICRO FEED (V), and PAPER SELECT switches (Be sure that the top cover is closed. Do not open it until you turn the printer power off.), then wait until the buzzer rings five times.

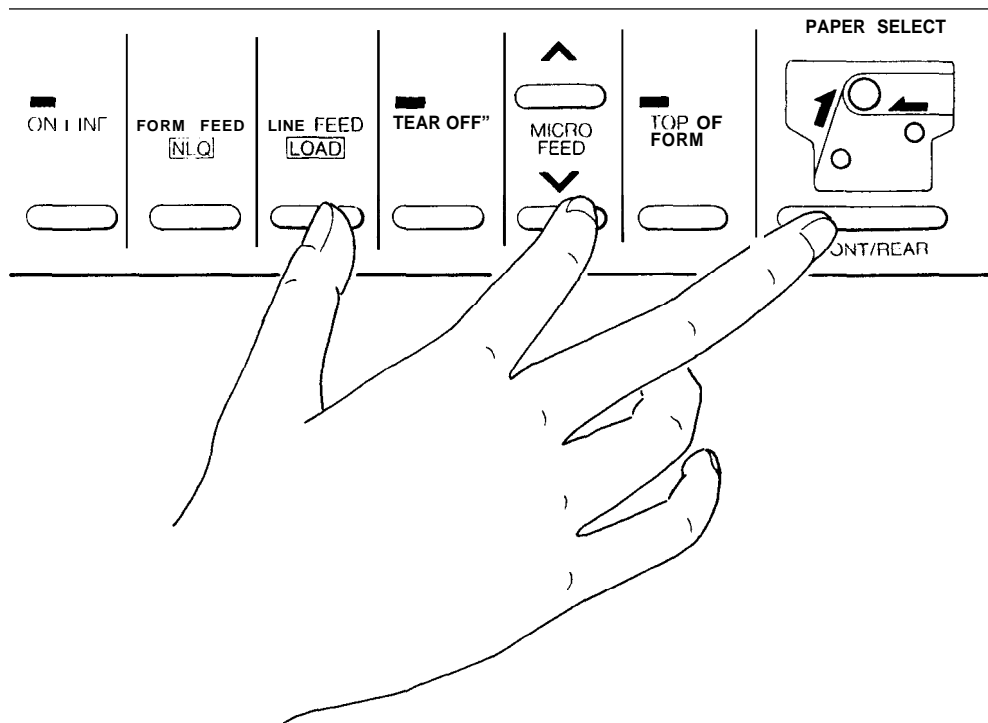

Figure 4-1. Entering the Adjustment Mode

REV.-A

**Step 3:** Load the paper by pressing either the LINE FEED or PAPER SELECT switch, then wait until the PAPER OUT lamp goes off (approximately 15 seconds).

**Step 4:** Press the ON LINE switch.

**Step 5:** Press the MICRO FEED (A) switch the number of times indicated by the value written on the front of the printhead.

- The buzzer rings each time the MICRO FEED switch is pressed.
- Press the MICRO FEED (A) switch to increment the value.
- Press the MICRO FEED (V) switch to decrement the value.
- The value range is 0 to 10.

**Step 6:** To confirm the value stored, press the FORM FEED switch so that the value is printed.

- If the value is incorrect, return to Step 5.
- When the value is correct, go to Step 7.

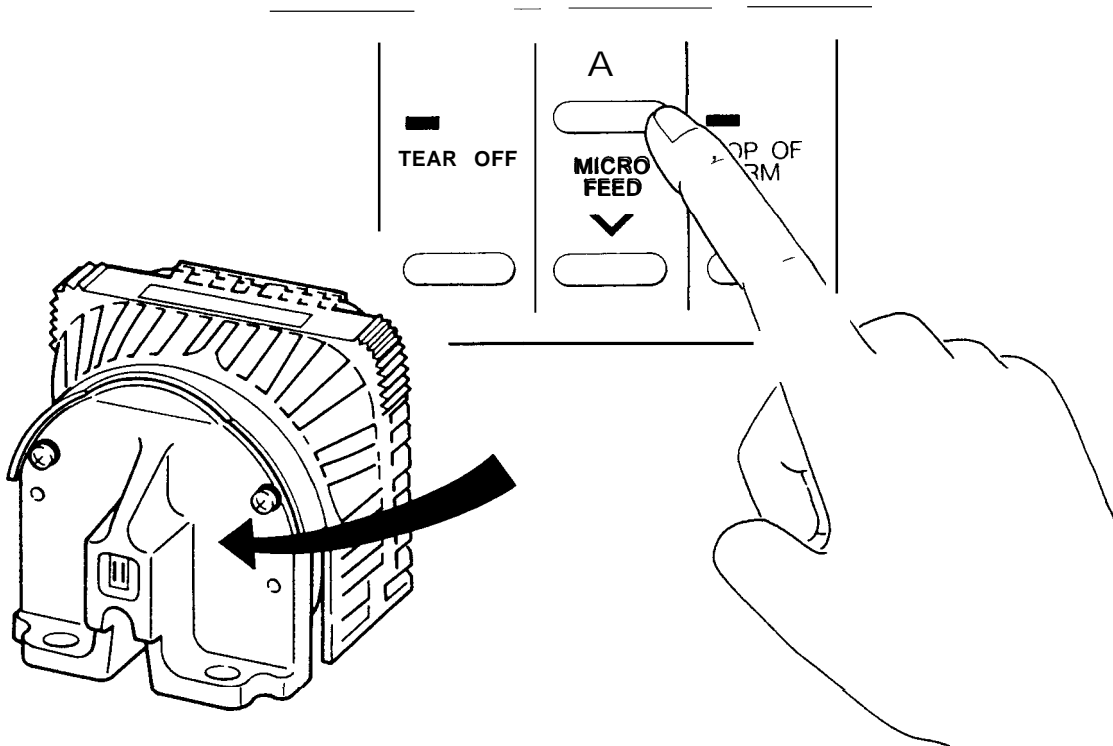

Figure 4-2. Writing the Adjustment Value

**Step 7:** Press the ON LINE switch and confirm that the buzzer rings five times. The printer prints the final value stored. If the value is correct, turn the printer power off.

### 4.3 BI-DIRECTIONAL PRINTING ADJUSTMENT

The purpose of this adjustment is to correct the printer mechanism parameters which control bidirectional printing. Be sure to perform this adjustment when required. If this adjustment is not performed correctly, bidirectional printing may be misaligned, or, in the worst case, the carriage might operate incorrectly.

Before performing this adjustment, be sure that the following adjustments are completed correctly.

#### 4.4 PARALLELISM ADJUSTMENT

#### 4.5 TIMING BELT TENSION ADJUSTMENT

The parameters to be written to the memory on the main board in this adjustment are as follows:

- Mechanism platen gap adjustment value (BETA)
- Head platen gap offset value (ALPHA)
- Head flying time adjustment value (FLYING TIME)
- Acceleration/deceleration timing belt delay time adjustment values (BELT DLYs (1) to (4))
- Bidirectional printing alignment value (BI-D ADJUST)

For 1 and 2 above, use the factory-determined values. For 3 to 5, you should be execute the adjustment as described below.

- Step 1: Mount the ribbon cartridge and load the paper (at either the front or rear tractor).
- Step 2: Turn the printer power on while pressing the LINE FEED, MICRO FEED (A), and FRONT/REAR switches. (Be sure that the top cover is closed. Do not open it until you turn the printer power off.)
- Step 3: Load the paper. (Press either the LINE FEED or FRONT/REAR switch.)
- Step 4: Write each parameter to the memory by following the flow chart shown in Figure 4-4.
- Step 5: After writing the parameters, turn the printer power off, then eject the paper and remove the ribbon cassette.

NOTES: 1. The range and units of each adjustment value are as follows:

- BETA : 0 to 150, 1 step
- ALPHA : 0 to 10, 1 step
- FLYING TIME : 280 to 460, 30 steps
- BELT DLY. : 0 to 6, 1 step
- BI-D ADJUST. : 0 to 48, 1 step

- 2. The ALPHA value is written on the printhead. (Refer to Figure 4-2.) The BETA value is written on the mechanism. (Refer to Figure 4-3.) To measure the BETA value, refer to Section 4.6.

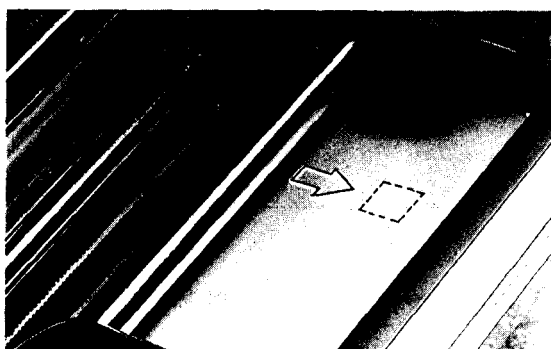

Figure 4-3. BETA Value



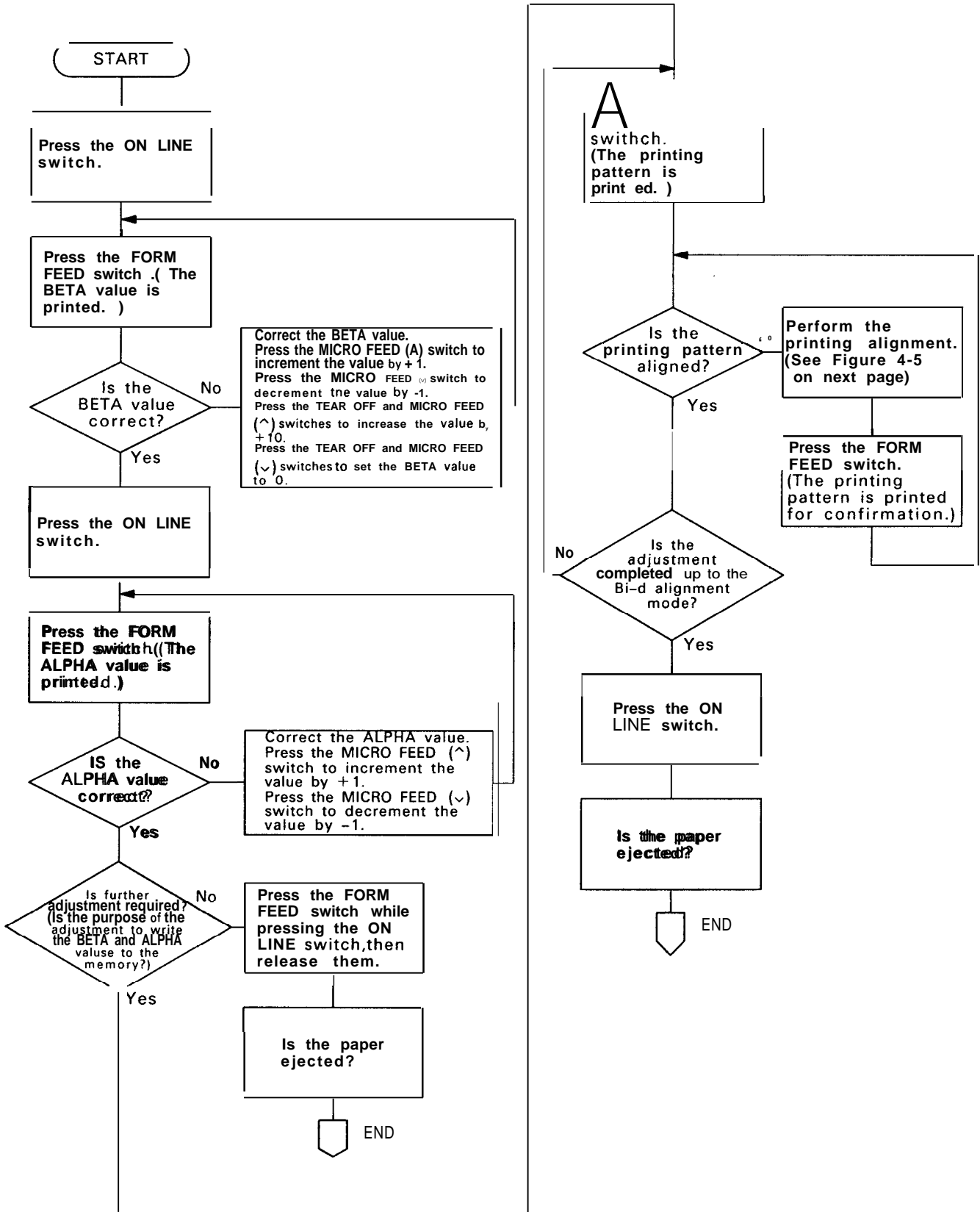

Figure 4-4. Bi-directional Printing Adjustment

For the flying time, belt delay time (1 to 4), and Bi-D alignment values, select the combination which minimizes the misalignment as shown below.

To shift the characters on the even-numbered lines to the right or left, relative to those on the odd-numbered lines, press either of the following switches.

- Press the TEAR OFF switch to shift the characters to the right.
- Press the LINE FEED switch to shift the characters to the left.

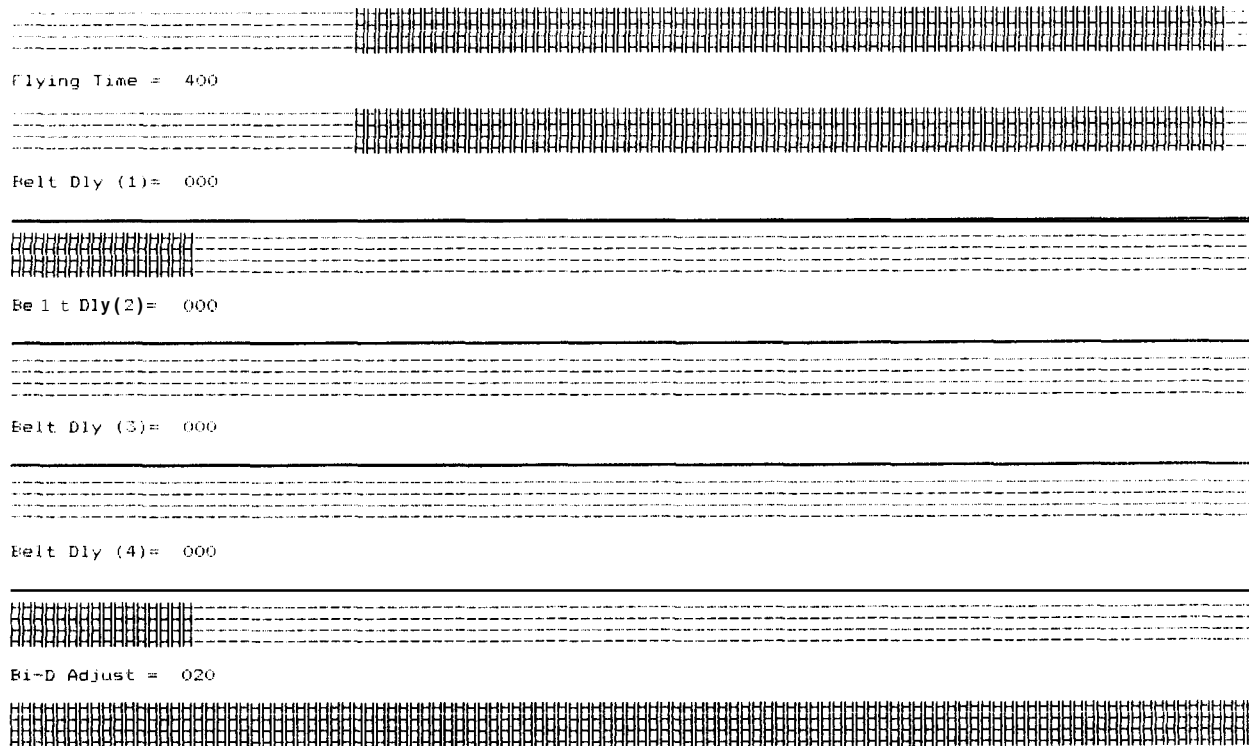

Figure 4-5. Printing Pattern

## 4.4 PARALLELISM ADJUSTMENT

The parallelism of the rear carriage guide shaft with respect to the platen must be correct. If the rear carriage guide shaft is not parallel to the platen, printing may be abnormal because the paper is not fed evenly at the left and right sides of the platen. A paper jam could occur.

Perform this adjustment with the printer mechanism removed.

### WARNING

The parallelism is adjusted so that the difference between the distances (between the platen and carriage guide shaft) measured at the two positions shown in Figure 4-8 are within the specified range. Since the specified value (0.0 1 mm) is extremely small, adjustment is impossible using normal methods. Make sure to use the dial gauge and dial gauge base supplied by EPSON. Do not adjust the parallelism using any other method.

- . Dial Gauge : #E672 (Part No. B7651 1 1401)
- . Dial Gauge Base : #F541 (Part No. B76511 4501)

NOTE: Dial gauge base #F541 is exclusively for the DFX-8000. It cannot be used for the DFX-5000.  
Dial gauge base #E661 also cannot be used for the DFX-8000.

Step 1: Loosen (but do not remove) the two screws securing the parallelism adjust lever.

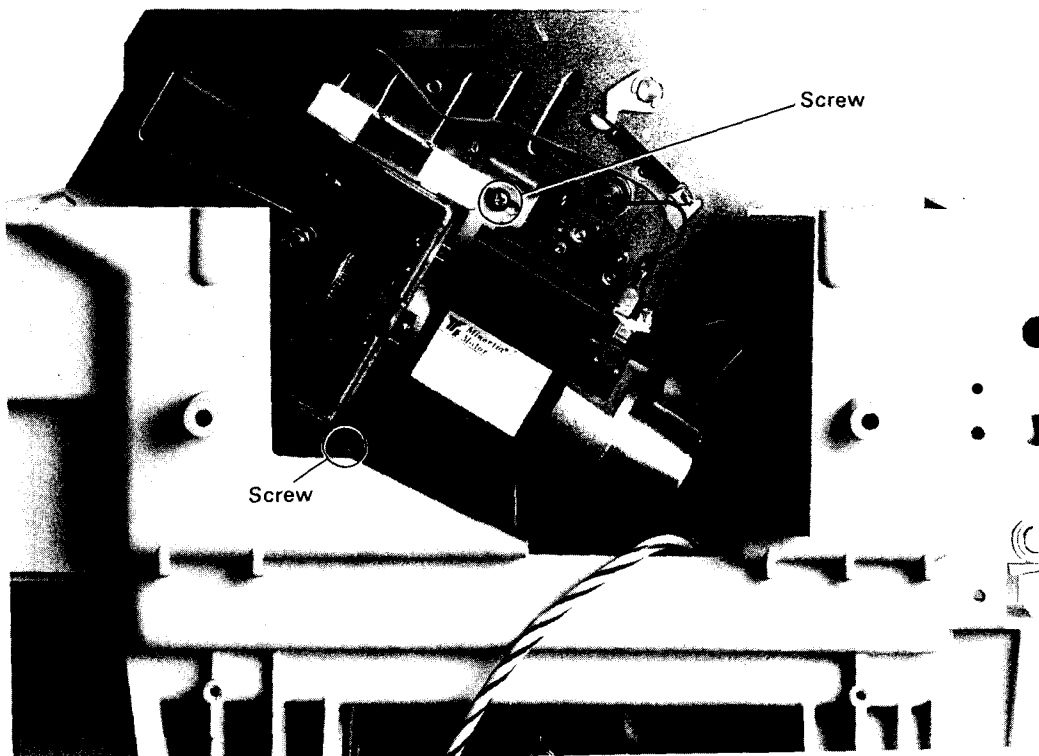

Figure 4-6. Parallelism Adjust Lever

- Step 2:** Remove the printhead and ribbon mask, and attach the dial gauge base in the same way as attaching the printhead. Loosen the screw on the base and adjust the gauge mounting position so that the tip of the gauge (portion A in Figure 4-8) is securely attached to the platen and the needle registers on the scale. (Do not forget to tighten the screw again.)

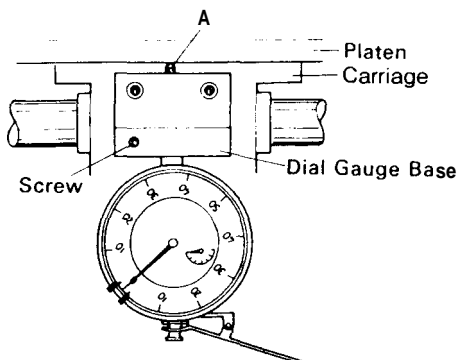

Figure 4-7. Dial Gauge and Dial Gauge Base Attachment

- Step 3:** Measure the distance between the left sides of the platen and carriage guide shaft, then the distance between the right sides, and compare.

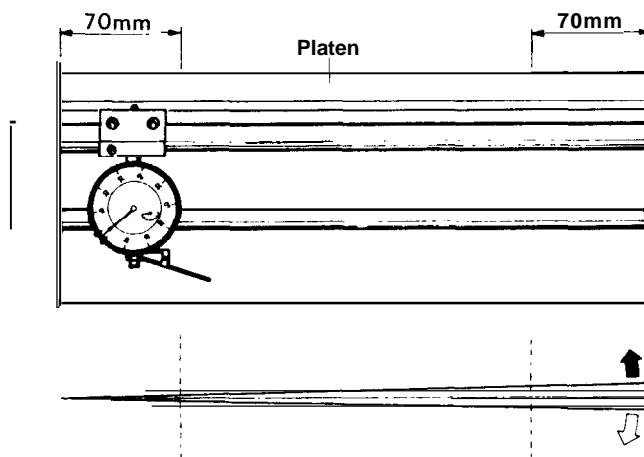

Figure 4-8. Carriage Guide Shaft Parallelism Adjustment

- Step 4:** If the distance measured at the left side is greater than that measured at the right side, move the parallelism adjust lever in the direction shown by the black arrow. If the distance measured at the left side is less than that measured at the right side, move the parallelism adjust lever in the direction shown by the white arrow. (Refer to Figure 4-6.)

**NOTE:** The carriage guide shaft moves as shown in Figure 4-8. For example, when the parallelism adjust lever is moved in the direction shown by the black arrow, the distance between the left side of the platen and shaft narrows a little bit as the distance between the right sides is narrowed.

- Step 5:** Repeat Steps 3 and 4 until the difference between the distances measured at the two positions is within 0.01 mm.
- Step 6:** When the difference is within the specified range, firmly tighten the two screws that secure the parallelism adjust lever, and measure the distance again as described in Step 3.
- Step 7:** When the difference between the measured distances is within the specified range, fix the two screws with screw lock. This completes the parallelism adjustment. (Refer to Chapter 6, Section 6.2 for lubrication and adhesive application.)

## 4.5 TIMING BELT TENSION ADJUSTMENT

The carriage motor timing belt tension must be adjusted when any part of the arriage mechanism, such as the carriage, carriage motor, belt pulley, or timing belt, is disassembled. Perform this adjustment with the upper case (and the printer mechanism) removed.

### WARNING

Before starting this adjustment, carefully fix the printer mechanism, because a force of 6.5 kg will be applied to it when the tension lever is pulled in the horizontal direction.

- Step 1: Completely loosen the three tension adjustment screws (A in Figure 4-9) on the carriage motor unit. (Loosen but do not remove them.)
- Step 2: Confirm that the timing belt is correctly attached and that no load is applied to it.
- Step 3: Insert the tension gauge hook through the hole (B in Figure 4-9) in the tension lever.
- Step 4: Pull the tension gauge horizontally (direction C in Figure 4-9) to apply a 6.5 Kg force.
- Step 5: Move the belt left and right while pulling the tension gauge, and move the motor pulley a little bit.
- Step 6: Tighten the three tension adjustment screws and fix them at the pulling force of 6.5 kg.
- Step 7: Fix the three tension adjustment screws with screw lock. (Refer to Chapter 6, Section 6.2 for lubrication and adhesive application.)

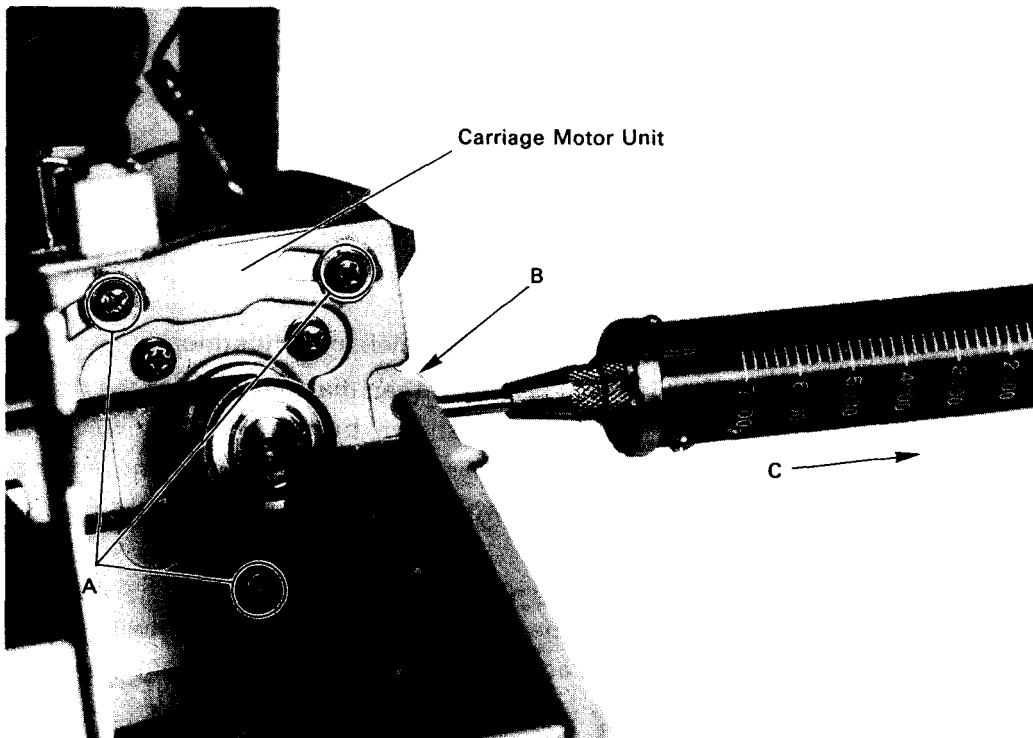

Figure 4-9. Carriage Timing Belt Tension Adjustment

## 4.6 MECHANISM ADJUSTMENT VALUE MEASUREMENT

This section describes how to measure the parameter (BETA value) for the PG mechanism unit. Since the BETA value is unique to each mechanism unit, it is written on the label as shown in Figure 4-3, so that it can be confirmed at a glance. Be sure to perform this measurement and correct the value written on the label because the value is necessary when the other units (board, printhead) are changed (when 61-DIRECTIONAL PRINTING ALIGNMENT (Section 4.3) is executed).

### WARNING

- This measurement is important because it determines the platen gap, so be sure to use the exclusive thickness gauge set and tension gauge supplied by EPSON.

Thickness gauge set (0.57 mm) : #F518 (Part No. 6776702201)

Tension gauge (200 gf) : #F545 (Part No. 676511 4601)

- This measurement cannot be executed for printers with ROM version BX2201. For those printers, first replace the ROM with a newer one (with a version later than BX2201).
- Do not turn the printer power off during Steps 3 to 16.
- When adjusting the platen gap to narrower or wider using the MICRO FEED (A) and MICRO FEED (V) switches, be sure to adjust the gap by 1 step at a time. If the gap is adjusted two or more steps at a time, the PG mechanism (PG motor) may not operate correctly. If this happens, perform the platen gap correction value adjustment from the beginning.

Step 1: Remove the ribbon cartridge, then load the paper.

Step 2: Close the top cover.

Step 3: Turn the printer power on while pressing the FORM FEED, MICRO FEED (A), and FRONT/REAR switches.

Step 4: Wait a few seconds, then open the top cover.

Step 5: Remove the printhead and the ribbon mask holder. (Refer to section 3.2. 1.)

Step 6: Attach the printhead. When attaching the printhead, pull it frontward, then tighten the left screw first with a torque of 12 kg cm. (Refer to section 3.2. 1.)

Step 7: Reset the ALPHA value by pressing the TEAR OFF and MICRO FEED switches simultaneously.

Step 8: Write the ALPHA value written on the printhead into the memory. (Refer to Figure 4-2.)

- Press the MICRO FEED (A) switch to increment the value by + 1.

- Press the MICRO FEED (V) switch to decrement the value by - 1.

Step 9: Confirm the ALPHA value written to the memory by pressing the FORM FEED switch. (If the value written is incorrect, return to Step 8.)

- The buzzer rings each time the MICRO FEED switch is pressed

Step 10: After writing the ALPHA value in the memory, press the ON LINE switch.

REV.-A

- Step 11: Move the printhead manually so that the center of the printhead is aligned to the 15th column on the printer scale.
- Step 12: Measure the BETA value by following the flow chart shown in Figure 4-11.
- Step 13: Remove the printhead. (Refer to section 3.2. 1.)
- Step 14: Attach the ribbon mask holder and the printhead. (When attaching the printhead, be sure to attach it as described in Step 6. Refer to section 3.2. 1.)
- Step 15: Mount the ribbon cartridge, then close the top cover.
- Step 16: Perform Steps 3 to 5 in Section 4.3. At this time, skip the steps for writing the ALPHA and BETA values because these values have already been stored in the memory.
- Step 17: Rewrite the BETA value on the mechanism unit product code No.label with the newly measured value. (Refer to Figure 4-3.)

< Example >

Case 1. Previous value: 140 gf (150 - 10)  
Current value : 180 gf (150 + 30)

The previous value is closer to 150 gf, so go to the "Previous" loop.

Case 2. Previous value: 120 gf (150 - 30)  
Current value : 160 gf (150 + 10)

The current value is closer to 150 gf, so go to the "Current" loop.

Case 3. Previous value: 140 gf (150 - 10)  
Current value : 160 gf (150 + 10)

In this case, we make it a rule to select the value which doesn't exceed 150 gf. Therefore, go to the "Previous" loop.

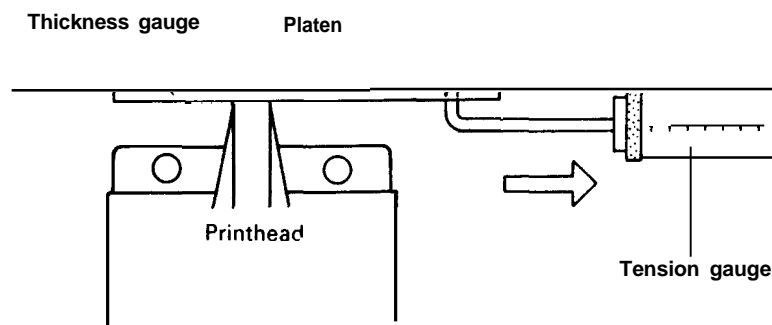

Figure 4-10. Pull the Thickness Gauge

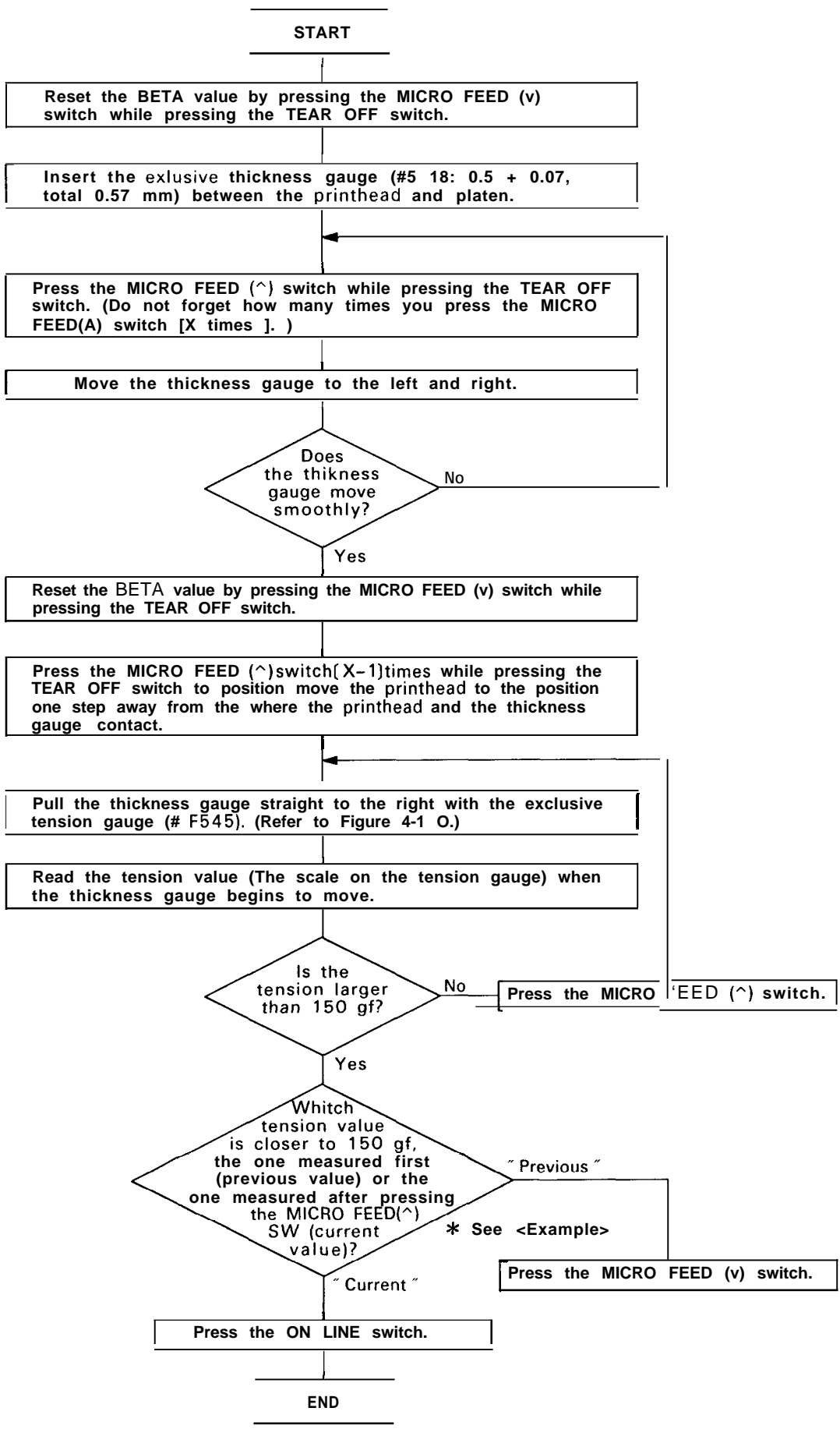

Figure 4-11. Mechanism Adjustment Value Measurement



# CHAPTER 5

## TROUBLE SHOOTING

5.1	GENERAL .....	5-1
5.1.1	Error Message Function .....	5-2
5.1.2	Bypass of The Interlock Switch and Cover-open Sensor.....	5-3
5.2	UNIT REPLACEMENT .....	5-5
5.3	POWER SUPPLY BOARD UNIT COMPONENT REPAIR .....	5-12
5.4	DRIVER BOARD UNIT COMPONENT REPAIR .....	5-15
5.5	MAIN BOARD UNIT COMPONENT REPAIR .....	5-17

## LIST OF FIGURES

Figure 5-1.	Troubleshooting Procedure .....	5-1
Figure 5-2.	Bypass Method of Interlock switch .....	5-3
Figure 5-3.	Bypass Method of Cover-open Sensor .....	5-3
Figure 5-4.	Unit Replacement - 1.....	5-5
Figure 5-5.	Unit Replacement .2.....	5-6
Figure 5-6.	Unit Replacement .3.....	5-7
Figure 5-7.	Unit Replacement .4.....	5-8
Figure 5-8.	Unit Replacement - 5.....	5-9
Figure 5-9.	Unit Replacement .6.....	5-10
Figure 5-10.	Printhead Cable Signal Assignmnet .....	5-11
Figure 5-11.	Sample Waveform for the Power Supply Board -1.	5-14
Figure 5-12.	Sample Waveform for the Power Supply Board -2.	5-14
Figure 5-13.	Sample Waveform for the Power Supply Board .....	5-14
Figure 5-14.	Sample Waveform for the Driver Board - 1 .....	5-16
Figure 5-15.	Sample Waveform for the Driver Board -2... ..	5-16
Figure 5-16.	Sample Waveform for the Driver Board -3... ..	5-16
Figure 5-17.	Sample Waveform for the Main Board - 1 .....	5-19
Figure 5-18.	Sample Waveform for the Main Board -2... ..	5-19
Figure 5-19.	Sample Waveform for the Main Board -3... ..	5-19

## LIST OF TABLES

Table 5-1.	Error Message .....	5-2
Table 5-2.	Problem Identification and Reference Pages .....	5-4
Table 5-3.	Power Supply Board Unit Component Repair .....	5-12
Table 5-4.	Driver Board Unit Component Repair .....	5-15
Table 5-5.	Main Board Unit Component Repair (cent' d)... ..	5-17

## 5.1 GENERAL

Because various types of problems can occur, troubleshooting is not easy to perform. Here is a simple procedure provided to perform troubleshooting.

**WARNING**

When you replace the unit, the adjustment that corresponded with each unit replacement should be performed. (Refer to CHAPTER 4.)

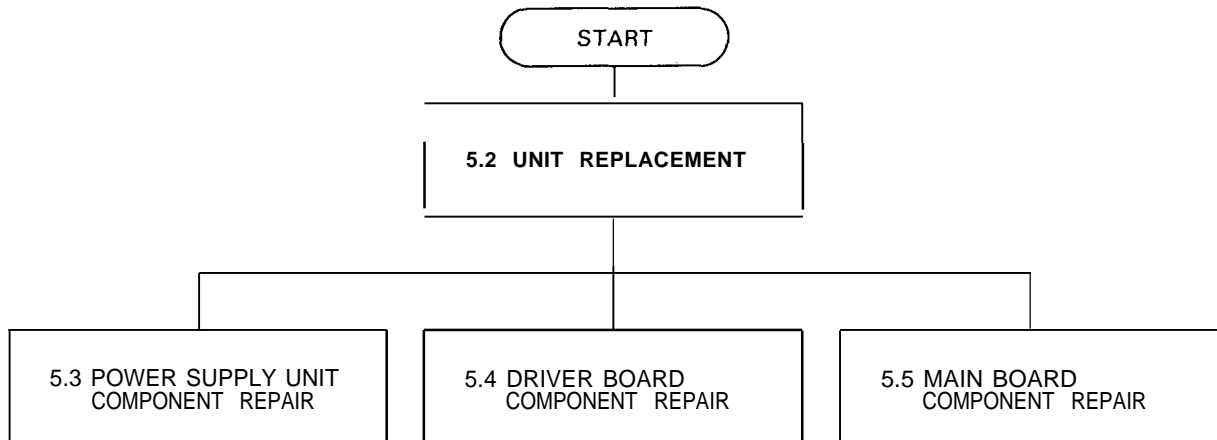

Figure 5-1. Troubleshooting Procedure

## 5.1.1 Error Message Function

The DFX-8000 indicates an error by ringing the buzzer. (Refer to Section 1.3.6.)

Table 5-1. Error Message

Error Indication	Symptoms	Cause
!!! X 6 times (Total 18 times)	Carriage Error	Carriage motor failure Home position sensor failure Carriage lock (PG abnormality) (Parallelism inclination) Timing belt tension loosen Carriage driver brown (Driver board) Gate array E05A38NA problem (Main board)
! X 5 times	Abnormal Voltage (DV35 Abnormality)	Power supply board failure Driver board failure (except head drive circuit)
!! X 6 times (Total 12 times)	CPU RAM Abnormality	CPU failure (Main board)
!! X 8 times (Total 16 times)	Lower Address RAM Abnormality	4C SRAM failure (Main board)
!! X 10 times (Total 20 times)	Upper Address RAM Abnormality	5C SRAM failure (Main board)
! X 10 or 1 1 times	Printhead Driver Abnormality	Head driver IC short or open (Driver board) Gate array E05A38NA problem (Main board)
!! X 16 times failure (Total 32 times)	Short Circuited Head Fan Driver	Head fan drive transistor (Driver board)
! X 3 times	Paper Error (Abnormal Paper Feed)	Tractor select mechanism failure Paper end sensor failure Paper feed motor failure Ribbon feed motor failure PF motor driver failure (Driver board) RF motor driver failure (Driver board)

### 5.1.2 Bypass of The Interlock Switch and Cover-open Sensor

When you requires printing with the top cover open, the interlock switch and the cover open sensor must be bypassed. Because these sensors automatically disable the printing operation when the top cover is taken off.

To bypass the interlock switch, remove the top cover, and close the left top cover hinge.

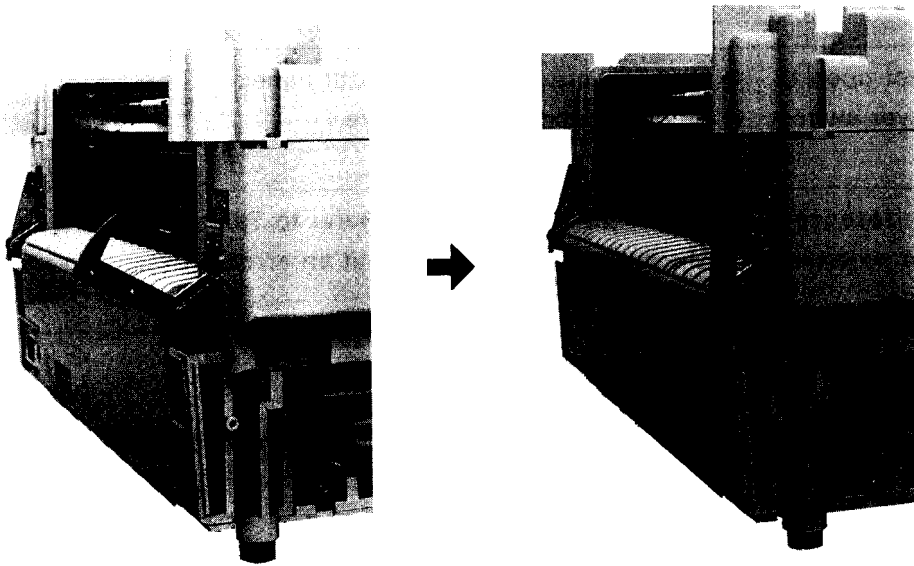

Figure 5-2. Bypass Method of Interlock switch

To bypass the cover-open sensor, remove the left side cover, disconnect the cable from connector CN9 on the MAIN board, and jumper pins 2 and 3 of CN9.

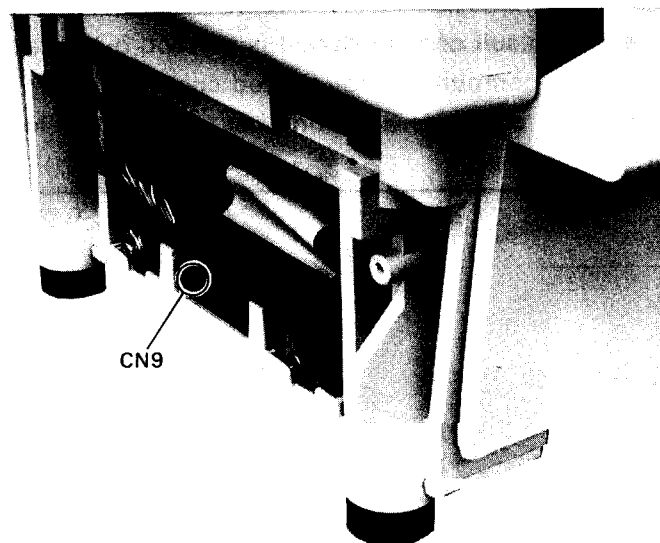

Figure 5-3. Bypass Method of Cover-open Sensor

## 5.2 UNIT REPLACEMENT

For troubleshooting, make repairs by unit replacement and adjustment, based on the problem symptoms.

Follow the corresponding flow chart after finding the problem in Table 5-2.

Table 5-2. Problem Identification and reference pages

Problem	Symptoms	Reference page
Printer does not operate at all with power switch ON.	<ul style="list-style-type: none"> <li>● No LEDs are lit on the control panel.</li> <li>● Mechanism doesn't initialize.</li> </ul>	5-5
An error is detected when power is switched ON.	<ul style="list-style-type: none"> <li>● Printer indicate an error. (Refer to Table 5-1.)</li> <li>● Mechanism can initialize but an error is detected.</li> </ul>	5-6
Printing error occurs. (In self-test)	<ul style="list-style-type: none"> <li>● Nothing is printing.</li> <li>● A specific dot is missing.</li> <li>● Print quality is bad (print density or other problem).</li> </ul>	5-7
Abnormal paper feed.	<ul style="list-style-type: none"> <li>● No paper is fed.</li> <li>● The amount of paper fed is irregular.</li> <li>● Paper jam occurs.</li> </ul>	5-8
Control panel does not operate correctly.	<ul style="list-style-type: none"> <li>● You cannot select function modes using control panel switches.</li> <li>● No paper is fed when you press the LINE FEED or FORM FEED switch in OFF-LINE mode.</li> <li>● You cannot select ON-LINE or OFF-LINE mode.</li> <li>● You cannot set panel settings.</li> </ul>	5-9
Incorrect printing in ON-LINE mode.	<ul style="list-style-type: none"> <li>● The result of the self-test is correct, but data from the host computer is not printed correctly.</li> <li>● Then printer is operating, an error occurs in the host computer.</li> </ul>	5-10

● The printer does not operate at all with power switch ON.

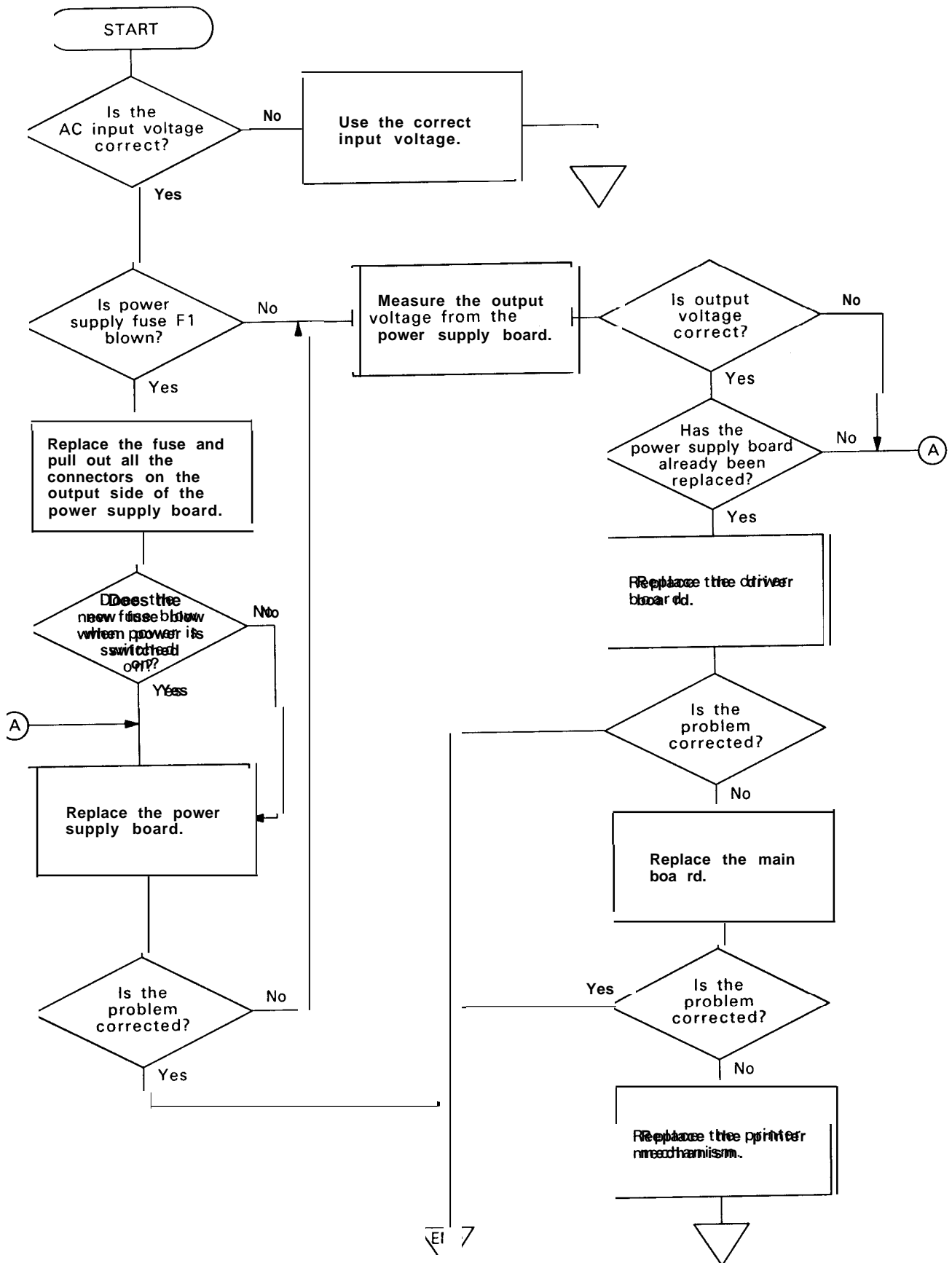

Figure 5-4. Unit Replacement -1

- An error is detected when power is switched ON.

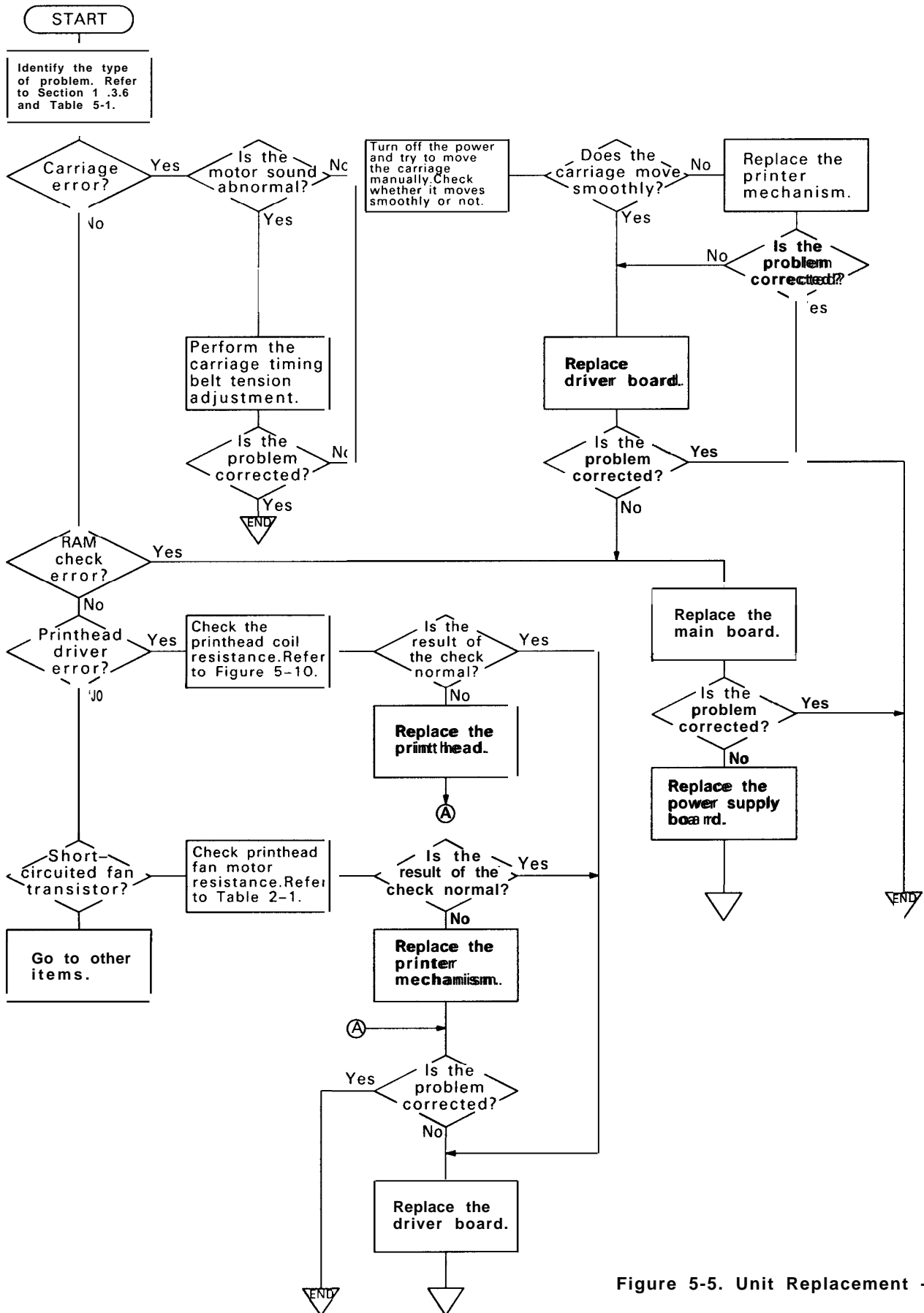

Figure 5-5. Unit Replacement - 2

● Printing error occurs (in self-test)

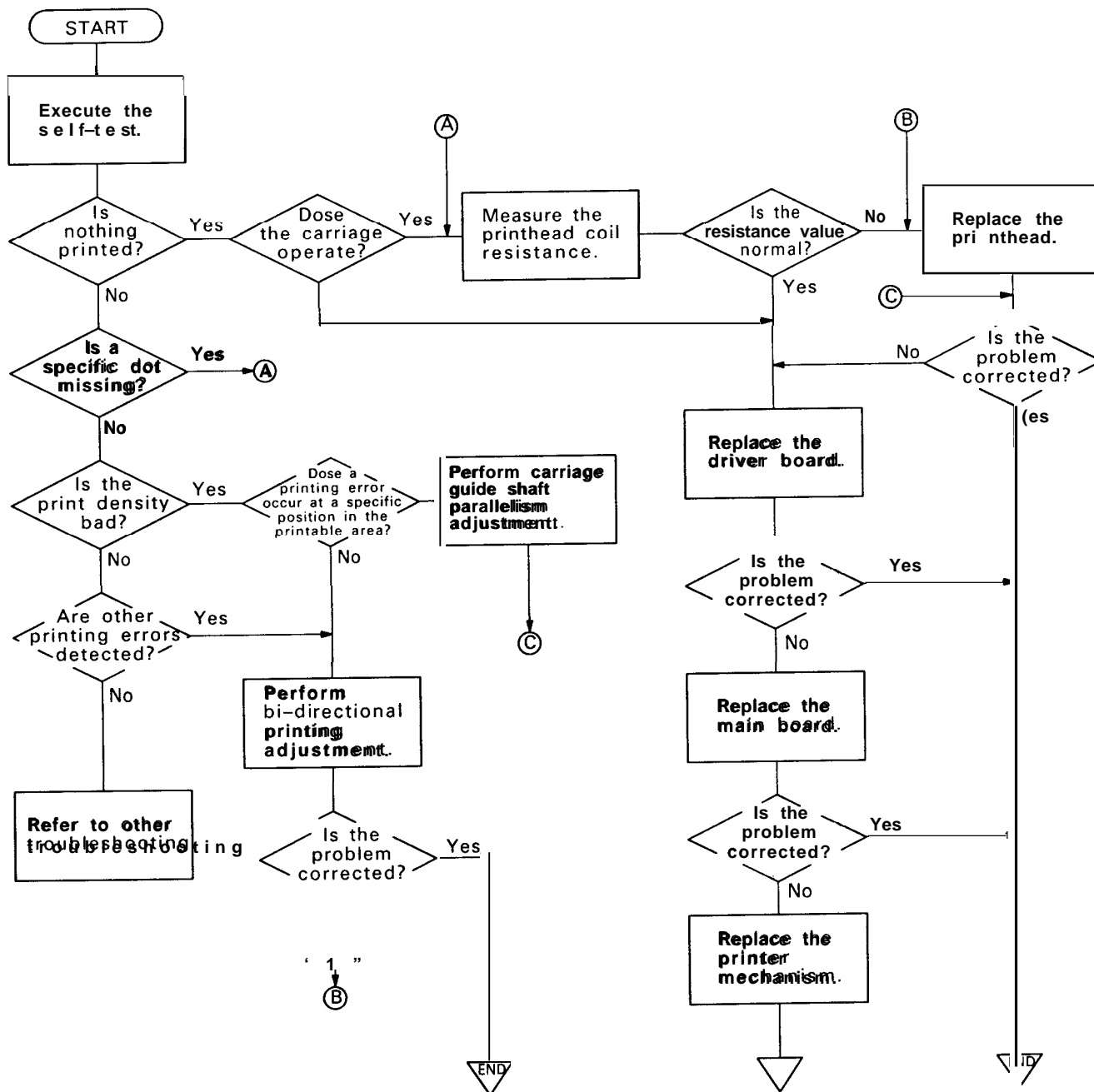

Figure 5-6. Unit Replacement -3



● Abnormal paper feeding

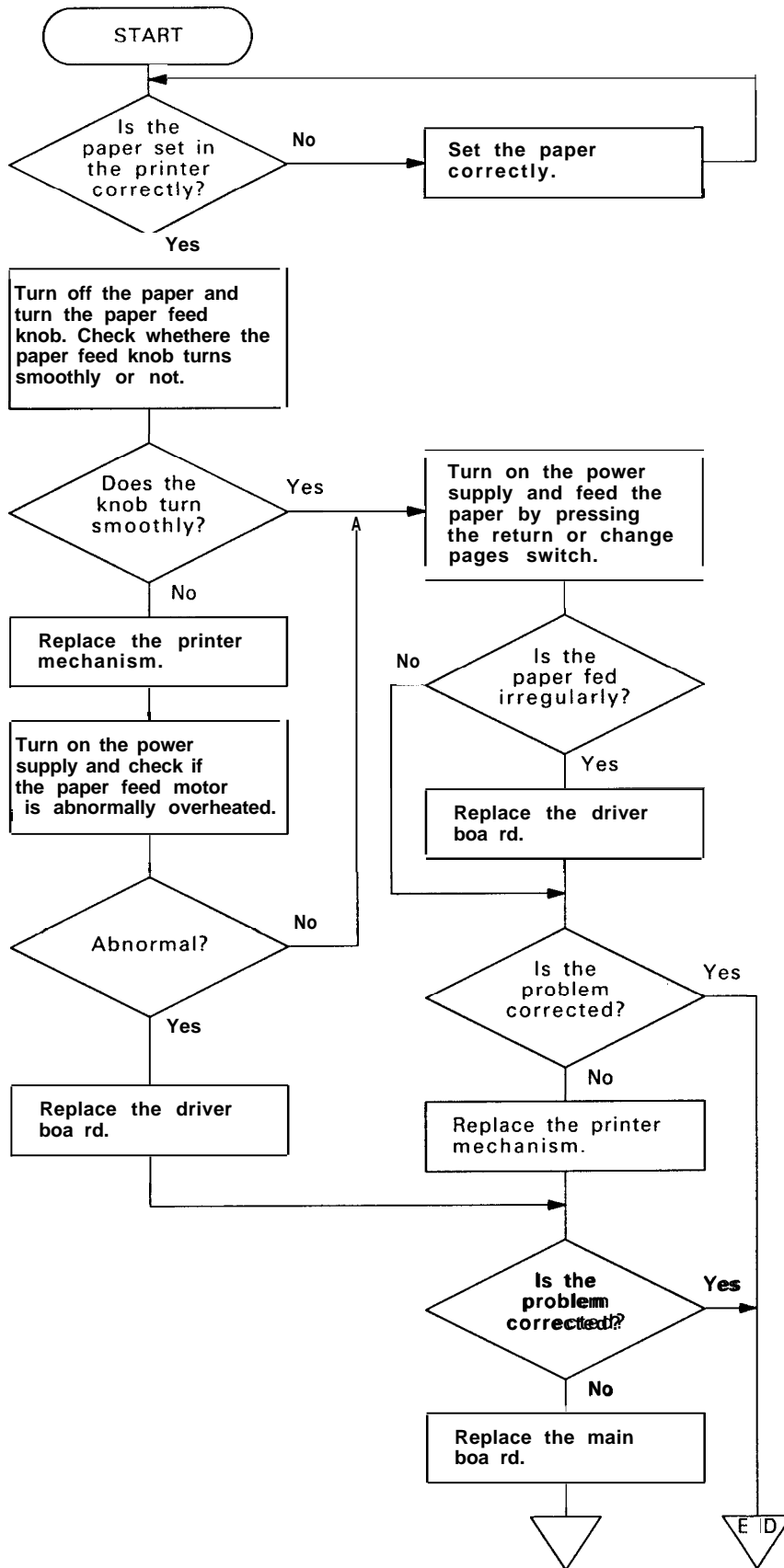

Figure 5-7. Unit Replacement -4

● The control panel does not operate correctly.

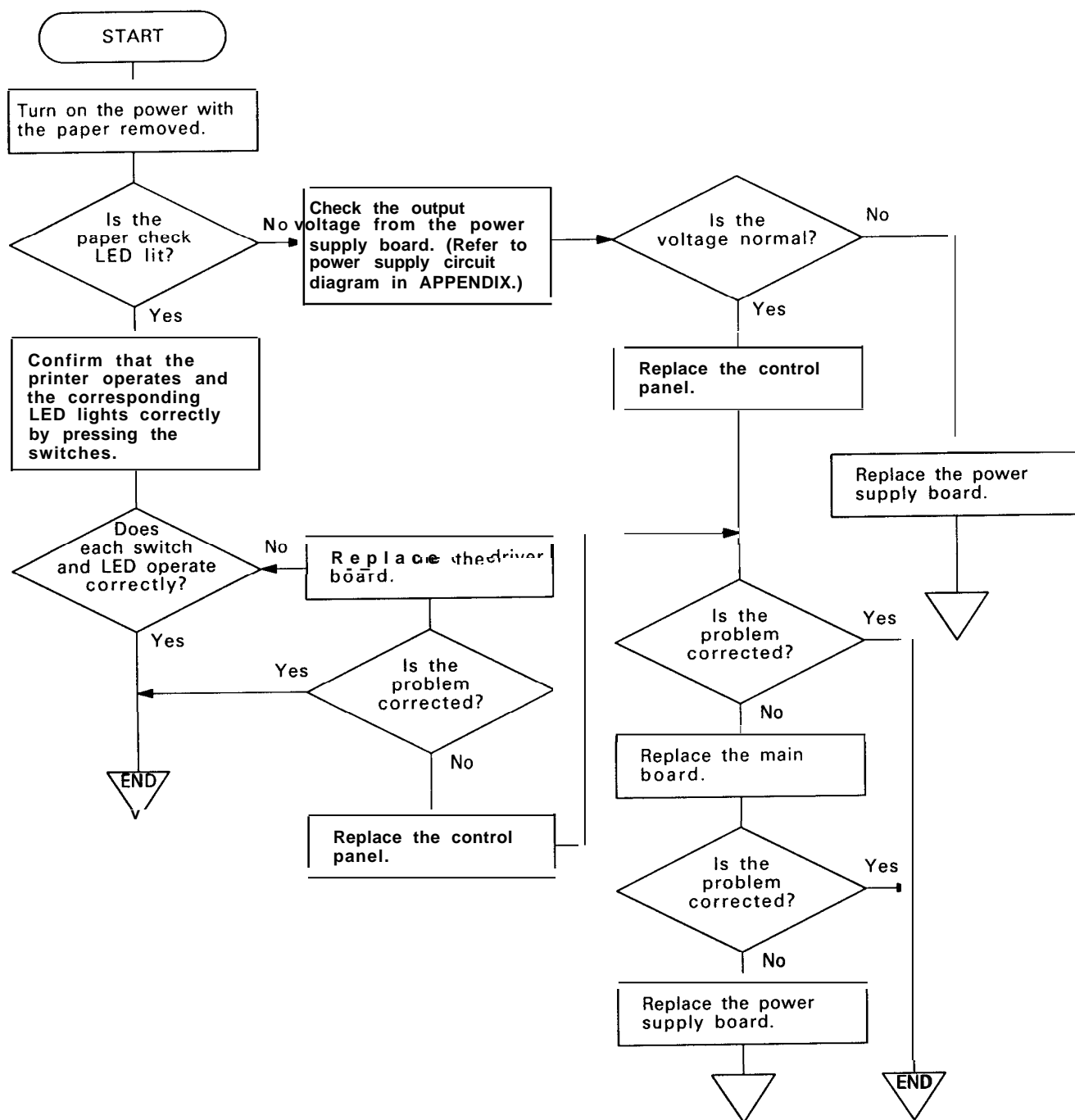

Figure 5-8. Unit Replacement -5

● Incorrect printing in ON-LINE mode.

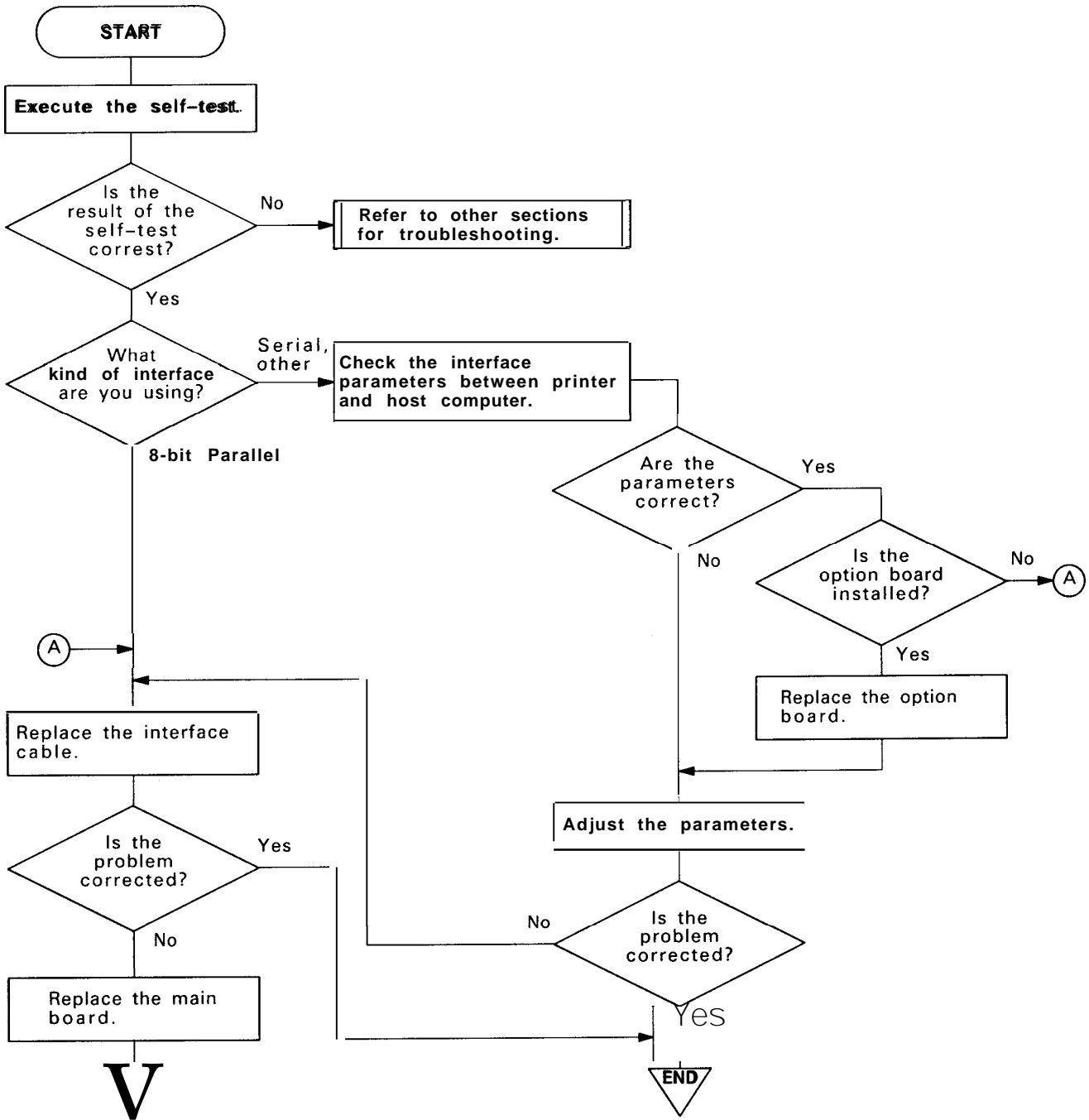
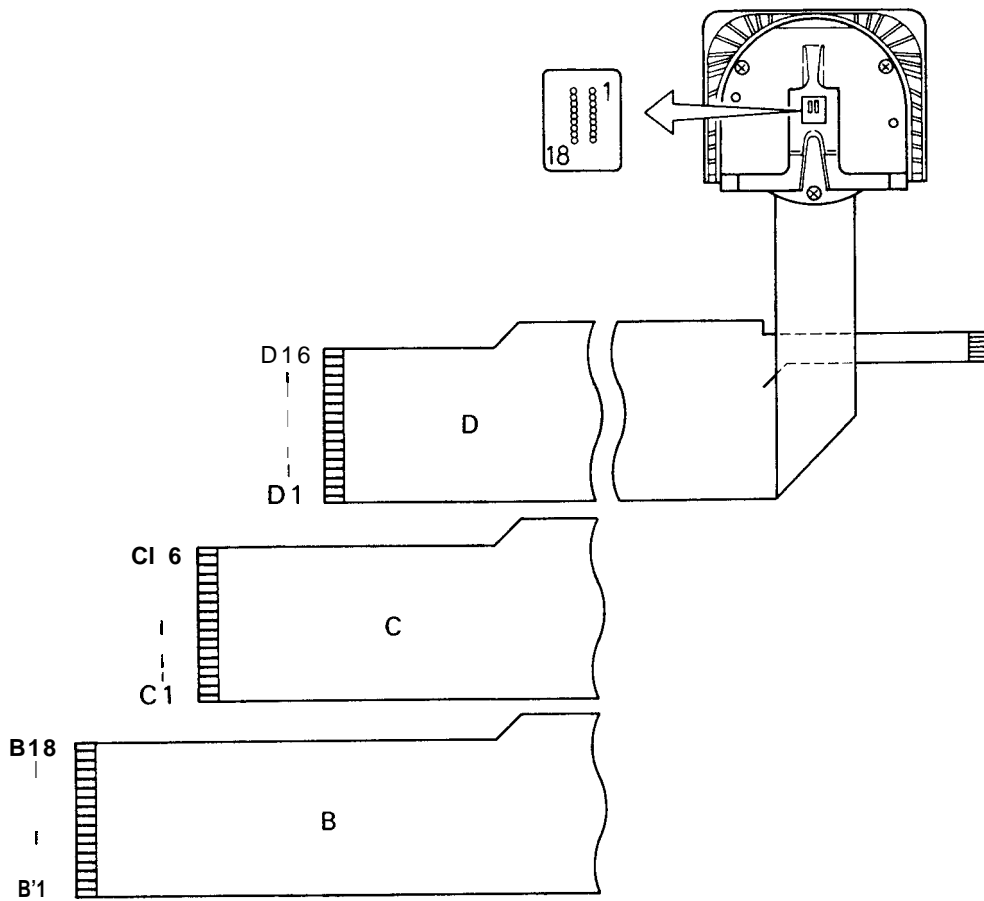

Figure 5-9. Unit Replacement -6



2.93 ohms / wire (Refer to Table 2-1, Section 2.1. 1.)

Figure 5-10. Printhead Cable Signal Assignmnet

NOTE: Pin numbers (B 1 - 18, C 1 - 16, D 1 - 16) in above are correspond with the pin assignments of Table A-1 8 in APPENDIX.

## 5.3 POWER SUPPLY BOARD UNIT COMPONENT REPAIR

This section describes the power supply circuit operation check and component repair of the BOPS/BOPSE board. Before starts the troubleshooting of the other units, you should be check the operation of power supply unit.

Table 5-3 shows the troubleshooting procedures for the power supply board unit

Table 5-3. Power Supply Board Unit Component Repair

Problem	Symptom	Cause	Checkpoint	Solution
Voltage is not output correctly.	F1 (fuse) is blown right after replacement.	The line filter circuit element is bad.	Check if any of C 1 – C7 or R 1 is shorting the AC line.	Replace the abnormal element(s).
		The rectifier circuit element is bad.	Check if DB 1 has shorted or if any of the elements connected between the positive and negative terminals of DB 1, C9, C 10, Q 1, Q2, etc. are shorted. . When DB 1 shorts, it may be because a short has occurred in a latter stage of DB 1.	Replace DB 1 and the abnormal element(s).
	None of the output voltages are normal.	DB 1 (diode bridge) is bad.	Verify that approximately 300V of DC voltage is output between the positive terminal (pin 3) and the negative terminal (pin 4) of DB 1. ● The output voltage of DB 1 may be constrained due to a problem with an element in DB 1's latter stage.	Replace DB1 and the abnormal element(s).
+35V DC is not normal.	None of the output voltages are normal.	The surge cut circuit is bad.	Measure the AC voltage between DB 1 pin 2 and L2 pin 4, and verify that it is approximately 0V. ● Either TY 1 is bad, or any of the components (R4, C8, D 1, or T 1 ) that switch TY1 are bad.	Replace TY 1 and the abnormal element(s).
		IC1 is bad.	Observe the drive waveforms of the switching transistors at IC 1 pin 8 and pin 11. (See Figure 5-1 1.) ● The drive waveforms of pins 8 and 11 have a phase difference, but the signal levels are the same. ● When DTC (pin 4) is at 100% (more than 3.5 V), the drive waveforms are not output.	Replace IC 1.
	Q1 and Q2 switching transistors are bad.	Observe the waveforms at the primary side (9 to 11 ) of transformer T1, and verify that Q1 and Q2 are switching. (See Figure 5-1 2.)	Replace Q1 and Q2, or the surrounding element(s) (including T1 and T3).	
	The rectifier diode DT1 is bad.	Verify that the DC voltage (approximately 35V) between TP 1 (+) and TP2(-) is output. . If no DC voltage is output, check the secondary (output) of T1.	Replace DT1 or the surrounding element(s).	

Table 5-3. Power Supply Board Unit Component Repair (cont'd)

Problem	Symptom	Cause	Checkpoint	Solution
Voltage is not output correctly.	Print DC is not normal.	The current limiting is bad.	Check if the outputs of any of indu (pin 1), 32 IH (pin 7) and 33 (Pin 7) is at the 5E1. (12V) level.	Replace the 5E1. or the surrounding element(s).
		The voltage limiting it-head is bad.	Check if the output of (7 pin) is at the IC (IA). If level. If the output of the C. is normal, check that is turned on.	Replace or the surrounding element(s).
		GND Level monitor circuit is bad.	Check if the output of (pin 1) is at the at tl ( 12V) level. If the output of rectl is normal, check that 3 A is turned on.	Replace or the surrounding element(s).
		Transistor Q7 is bad.	The collector of transistor Q7 is at approximately . None of the outputs of and are active.	Replace Q7 or the surrounding element(s).
		is bad.	CL signal (CN4 pin 3) is output at the wrong time. . When the CL signal is output, the PD signal is output from the MAIN Board to turn Q7 on.	Replace or the surrounding element(s).
		FAN is bad.	Remove connector CN5.	Replace the FAN.
+ 5V DC is not normal.	Switching transistor Q4 is bad.	Observe the switching waveforms of a P-R collector. (See Figure 13.) ● Verify that Q6 is not turned on when there's no oscillation. ● Q5, D3, C 18, and T4 play the major roles in switching operation.	Replace Q4 or the surrounding element(s).	
	The rectifier diode DT2 is bad.	Verify that DC voltage y of the ble: an: is output between the negative and positive terminals of C42 or C43. ● If no DC voltage is output, check the secondary output of T4.	Replace DT4 or the surrounding element(s).	
	The voltage control is bad.	Check that transistor Q6 remains on. ● Q6 is turned on and off by and Q8 through the PC2 photo coupler. ● 1C4A limits the voltage to + and Q8 stabilizes it.	Replace Q6 or the surrounding Also replace any of PC2, or Q8, if necessary.	
+ 1 2V DC is not normal.	The rectifier circuit is bad.	Verify that approximately + 12V is output at the terminals of C40. ● + 12V is also used to power the (OP AMPS) on the board.	Replace D8 or C40.	

Table 5-3. Power Supply Board Unit Component Repair (cont'd)

Problem	Symptom	Cause	Checkpoint	Solution
Voltage is not output correctly.	- 12V DC is not normal.	The rectifier circuit is bad.	Verify that approximately - 12V is output at the terminals of C4 1. ● - 12V is also used to power the IC's (OP AMPs) on the board.	Replace D9 or C4 1.
The backup of the specified values at the Main Board are not made.	The Switch Off (SO) signal is not normal.	SO signal output circuit is bad.	Verify that the SO signal (CN4 pin 1 ) is output when the AC line voltage is lowered using a sliduck and the voltage between the negative and the positive terminals of DB 1 is lowered to approximately 170V. ● The SO signal is output from IC5B through the PC 1 photo coupler when Q3 turns on.	Replace Q3, PC 1, and IC5A, or the surrounding element(s).

i

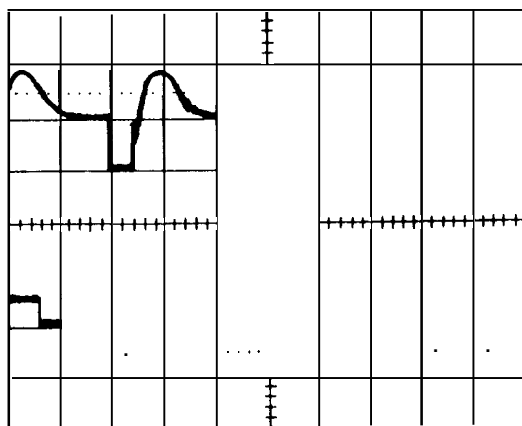

**Figure 5-11. Sample Waveform for the Power Supply Board -1**

The waveform for the +35V switching transistor drive (IC 1 pins 8 and 1 1)

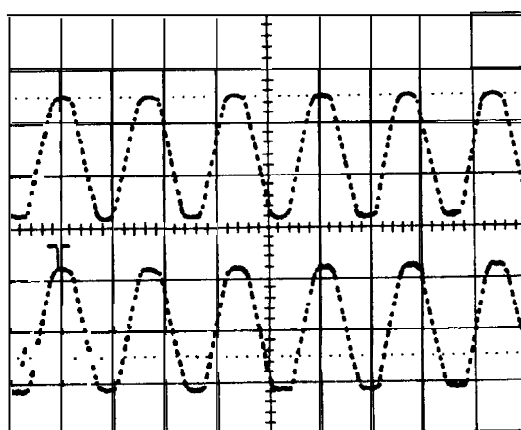

**Figure 5-12. Sample Waveform for the Power Supply Board -2**

The waveform for the +35V pulse drive (pins 9 and 11 of T1)

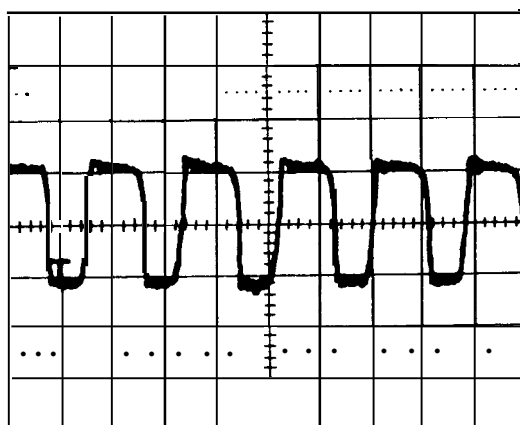

**Figure 5-13. Sample Waveform for the Power Supply Board**

The waveform for the + 5V pulse drive (Q4 collector)



## 5.4 DRIVER BOARD UNIT COMPONENT REPAIR

This section describes the driver circuit operation check and component repair of the C030DRV board. Table 5-4 shows the troubleshooting procedures for the driver board unit.

Table 5-4. Driver Board Unit Component Repair

Problem	Symptom	Cause	Checkpoint	Solution
An error is detected.	"Carriage error" is detected.	The home position cannot be detected.	Verify that connectors CN4 and CN5 are properly connected.	Check the connector pins of CN4 and CN5 and the route of the CR HP signal.
		The CR motor driver is bad.	Observe the CR motor drive signal at pins 30 and 31 (CRA and CRB) of connector CN6. (See Figure 5-14.)	If abnormal, replace the IC(4E) or the surrounding element(s). If normal, check the connectors and the cables.
	"Short circuited fan transistor"	The fan transistor is bad.	Check transistors Q2(FANCOM), Q3 (HFANB), and Q5 (HFANA) for shorts or opens.	Replace the corresponding element(s).
	"Printhead driver abnormal"	The print-head driver is bad.	Examine pins 24 (HP ERR) and 23 (HN ERR) of connector CN4, and check on which of the two rows of the head driver the error occurred. Determine which of the 6 error detecting IC's (DA 1 - DA6) (two sets, three IC's in one set) has detected the error. If the printing is not normal, replace the driver IC's (2B, 4B, 2C, 4C, 2D, and 4D). If the printing is normal, replace the error detecting IC's.	Replace the corresponding element(s).
Printing is not normal.	The print-head is not controlled correctly.	The print-head driver is bad.	Observe the output waveforms of the driver IC('s) corresponding to the column(s) where the printing is not normal. (See Figure 5-15.)	Replace the driver IC('s).
	The CR motor is not controlled correctly.	The CR motor driver is bad.	Observe the CR motor drive signal at pins 30 and 31 (CRA and CRB) of connector CN6. (See Figure 5-14.)	Replace the IC (4E) or the surrounding element(s).
Paper feeding is not normal.	The PF motor is not controlled correctly.	The PF motor driver is bad.	Check the PF motor drive signals at pins 22, 24, 25, and 28 (PFA - PFD) connector CN6, and the common voltage at pins 32 and 34. (See Figure 5-16.)	Replace the IC (2E) or the surrounding element(s).

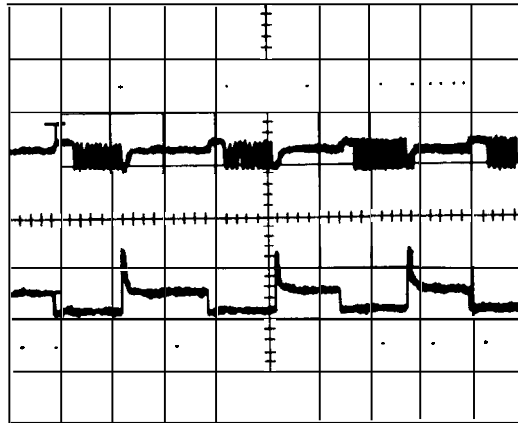

Figure 5-14. Sample Waveform for the Driver Board -1  
CR motor drive waveform (pins 30 and 31 of connector CN6)

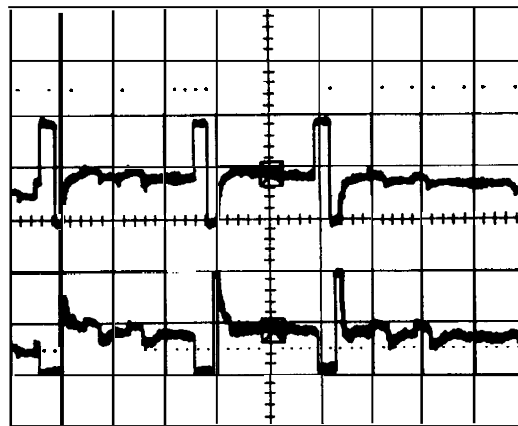

Figure 5-15. Sample Waveform for the Driver Board -2  
Printhead drive waveform (Connector CN6.Upper:PNP, Lower:NPN)

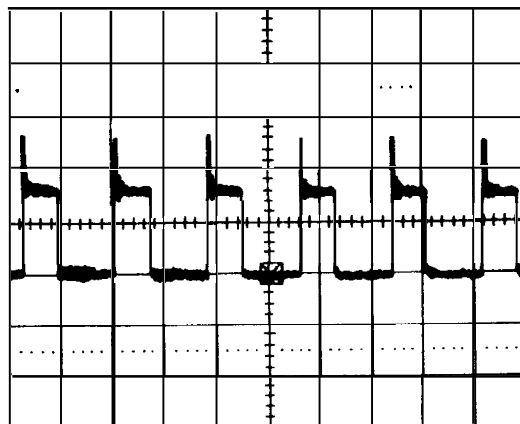

Figure 5-16. Sample Waveform for the Driver Board -3  
PF motor drive waveform (pins 22, 24, 25 and 28 of connector CN6)

## 5.5 MAIN BOARD UNIT COMPONENT REPAIR

This section describes the circuit operation check and component repair of the C030MAIN board. Table 5-5 shows the troubleshooting procedures for the main board unit.

Table 5-5. Main Board Unit Component Repair

Problem	Symptom	Cause	Checkpoint	Solution
It doesn't operate at all.	The reset signal is not canceled.	The reset circuit is bad.	Turn the printer on and check that pin 21 of IC (5E) goes High after a certain time. ● if it goes High, see the column entitled "The CPU does not operate."	Replace any abnormal element(s) among Q2, ZD2, C28, and the surrounding elements.
	The CPU does not operate.	The clock signal is dead.	Observe the clock waveforms at pins 22 and 23 of IC (5 E). (See Figure 5-1 7.)	Replace CR2 or IC (5 E).
		The program ROM is bad.	Check that IC (3B) is inserted correctly. If it's correct, replace the ROM.	Replace IC (3 B).
	The CPU is bad.	Check that the signal goes High and Low at pin 40 (ASTB) and pins 41 to 48 (ADO to AD7) of IC (5 E).	Replace IC (5 E).	
An error is detected.	"Carriage error" is detected.	The home position cannot be detected.	Turn the home position sensor on and off, and see if the waveform at pin 5 of IC (5E) goes High and Low.	If it does, replace IC (5 E). If it doesn't, check the route of the CR HP signal.
		The CR motor control circuit is bad.	Observe the CR motor drive signal at pins 18 to 21 (CRA to CRD) of IC (6A). (See Figure 5-1 8.)	If abnormal, replace IC (6A) or IC (5 E). If normal, Check the connectors and cables.
	"Abnormal voltage"	The CPU is bad.	Check if the CL signal is active at pin 5 of IC (5 E). ● If it remains active, check the signal route (cables, connectors, and circuit board patterns) to the IC (5 E).	Replace IC (5 E).
	"RAM check abnormal"	The memory circuit is bad.	Determine in which RAM the error occurred according to the number of buzzers.(See Table 5-1.)	Replace the corresponding element(s). If the replacement of IC'S (6C and 4C) doesn't fix the problem, replace IC (6A) or IC (5 E).
	"Short circuited fan transistor"	The detecting circuit is bad.	Replace IC (6A). Check the route of the HF ANA and HF ANB signals.	Replace IC (6A) or IC (5 E).

Table 5-5. Main Board Unit Component Repair (cont'd)

Problem	Symptom	Cause	Checkpoint	Solution
An error is detected.	"Printhead driver abnormal"	The CPU is bad.	Check if an error signal has been input at pin 32 (HP ERR) or pin 33 (HN ERR) of IC (5 E). If not, check the signal route.	Replace IC 5E.
Printing is not normal.	The print-head is not controlled correctly.	The print-head control circuit is bad.	Replace IC (6A). If it still doesn't work, replace the C.G.ROM:IC (36) or the CPU.	Replace the corresponding element(s).
	The CR motor is not controlled correctly.	The CR motor control circuit is bad.	Verify that the drive signal of the CR motor is correctly output at pins 16 (CR A) through 19 (CR D) of CN5. ● The CR motor is controlled by the CPU:IC (5 E), G. A.:IC (6A), and the driver IC (7A).	Replace the corresponding element(s).
Paper feeding is not normal.	The PF motor is not controlled correctly.	The CPU is bad.	Verify that the PF motor drive signal is correctly output at pins 26 (PF D) through 29 (PF A) of the CPU:IC (5 E). (See Figure 5-1 9.) ● The PF H/R signal is output from the G. A.:IC (2 E).	Replace the corresponding element(s).
DIP switches cannot be set.	The specified values of the DIP switches cannot be read.	The DIP switch reading circuit is bad.	Replace IC (2 E). If it still doesn't work, replace the CPU:IC (5E) or the P-ROM:IC (3 B). ● When only a particular bit is involved, replace the DIP switch and the diode for that bit.	Replace the corresponding element(s).
Control panel doesn't operate correctly.	The switches and/or LED of the control panel do not work.	Gate array is bad.	Replace IC (2 E). If it still doesn't work, replace the CPU:IC (5E) or the P-ROM:IC (3 B). ● Check the continuity of the cables and connectors on the control panel.	Replace the corresponding element(s).
Host computer cannot make it operate properly.	A data communication error is detected or data is garbled.	The interface elements are bad.	Observe the interface signal causing the error while communicating with the host computer. ● Parallel I/F DATA 1 - 8, STROBE, ACK, BUSY ● Serial I/F TXD, RXD, DTR	Replace the parallel port IC (6A or 2E). Replace the serial port IC's (1 D, or 1 E, 6A and 2E).
		The CPU is bad.	If the interface elements are good, the CPU may be bad.	Replace IC (5 E).
Mode settings are not saved.	The memory backup is not performed.	The memory backup circuit is bad.	The lithium battery or the transistor (Q3 and Q4) in the memory backup circuit is bad.	Replace the corresponding element(s) or the surrounding element(s).

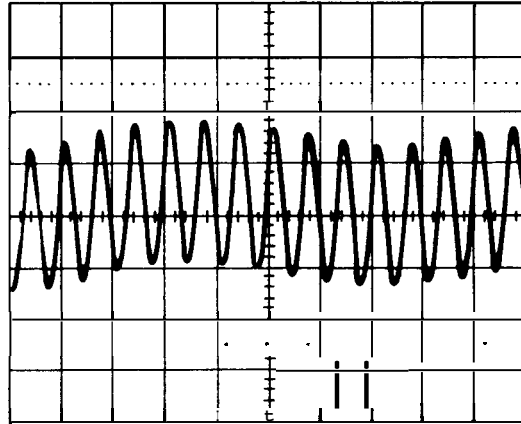

**Figure 5-17. Sample Waveform for the Main Board -1**  
The CPU clock waveform (IC (5E) pins 22 and 23)

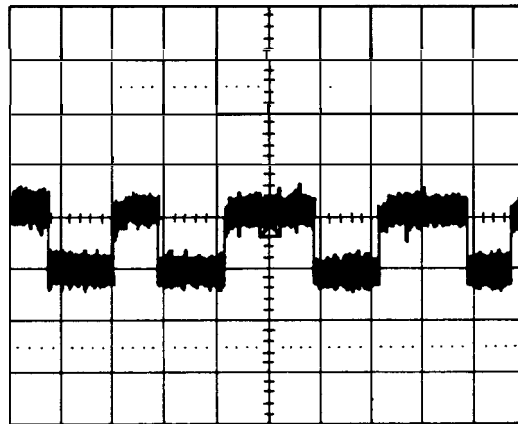

**Figure 5-18. Sample Waveform for the Main Board -2**  
The CR motor control signal waveform (IC (6A) pin 18)

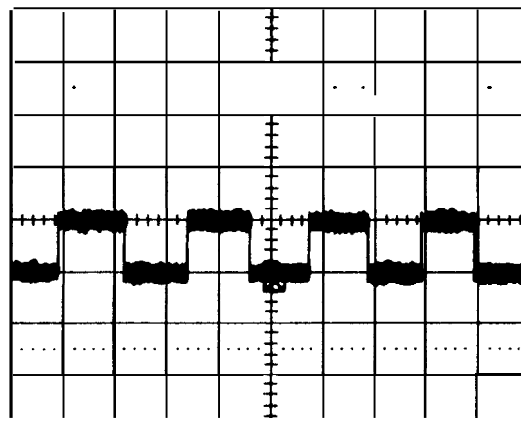

**Figure 5-19. Sample Waveform for the Main Board -3**  
The PF motor control signal waveform (IC (5E) pin 26)

# CHAPTER 6 MAINTENANCE

6.1 PREVENTIVE MAINTENANCE ..... 6-1  
6.2 LUBRICATION AND ADHESIVE APPLICATION ..... 6-1

## LIST OF FIGURES

Figure 6-1. Correct Adhesive Application ..... 6-1  
Figure 6-2. DFX-8000 Lubrication and Adhesive Diagram 1 ..... 6-4  
Figure 6-3. DFX-8000 Lubrication and Adhesive Diagram 2..... 6-5  
Figure 6-4. DFX-8000 Lubrication and Adhesive Diagram 3..... 6-6

## LIST OF TABLES

Table 6-1. Lubricants and Adhesive ..... 6-1  
Table 6-2. Lubrication Points ..... 6-2  
Table 6-3. Adhesive Application Points ..... 6-3

## 6.1 PREVENTIVE MAINTENANCE

Proper maintenance is essential to maintain optimal printer performance for the longest possible period and to minimize malfunction frequency.

Preventive maintenance includes regular cleaning of the case exterior, using neutral detergent, and occasional vacuuming of the mechanism interior to remove dust and paper particles.

Following cleaning, refer to Section 6.2 to verify that the unit is adequately lubricated. Before returning the serviced printer to the consumer, inspect the springs, paper feed rollers, and the basic operation of the unit.

### WARNING

Disconnect the printer from the power supply before performing maintenance. Do not use thinner, trichloroethylene, or ketone-based solvents on the plastic components of the printer.

## 6.2 LUBRICATION AND ADHESIVE APPLICATION

EPSON recommends that the points illustrated in Figures 6-2, 6-3 and 6-4 be lubricated, with EPSON 02 and G26, which have been extensively tested and found to comply with needs of this printer. (Refer to Table 6-1 for details of 02 and G26.)

Table 6-2 indicated the lubricant for each points.

Be sure that the parts to be lubricated are clean before applying lubricant, and avoid excessive application, which may damage related parts.

Adhesive application is necessary at the point indicated in Table 6-3 when the part is disassembled or replaced. EPSON recommends Neji Lock #2(G) adhesive be applied to the point diagramed in Figures 6-2, 6-3 and 6-4.

Avoid overflow of excess to related parts.

Table 6-1. Lubricants and Adhesive

Classification	Description	Capacity	Availability	Parts No.
Oil	02	40CC	EPSON	B7 10200001
Grease	G26	40g	EPSON	B702600001
Adhesive	NEJI LOCK #2 (G)	100g	EPSON	B730200200

NOTE: EPSON = EPSON-exclusive product

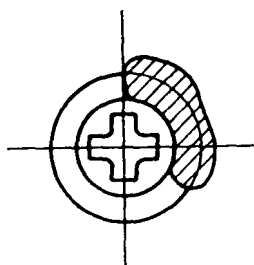

Figure 6-1. Correct Adhesive Application

Table 6-2. Lubrication Points

Ref No.	Reference Figure No.	Lubrication Points	Lubricant
1	6-3	Oil pad ring of the carriage (in the both sides left and right sides of carriage)	02
2	6-3	Oil pad of the carriage (under the head cable holder of carriage)	02
3	6-3	Hooking points of the paper guide support plate spring (6 points)	G26
4	6-3	Holding hole edge of the rear carriage guide shaft (both left and right sides of frame)	G26
5	6-3	Both ends of the carriage guide shaft	G26
6	6-3	Parallelism adjustment lever (contact point with the rear carriage guide shaft)	G26
7	6-3	Carriage guide shaft holding lever (contact point with the rear carriage guide shaft)	G26
8	6-3	Carriage guide shaft (on the both front and rear shaft)	02
9	6-2	Shaft of paper feed gear. (shafts on the left frame)	G26
10	6-2	Shaft of paper feed gear. (shafts on the left frame)	02
11	6-2	Paper feed gears (gears on the left frame)	G26
12	6-2	Paper feed gears (gears on the left frame)	G26
13	6-2	Tension pulley (pulley shaft and hooking point of the tension pulley spring)	G26
14	6-4	Paper bail gear	G26
15	6-4	Hooking point of the paper bail spring	G26
16	6-4	Fulcrum position of the paper bail shaft and plunger.	G26
17	6-4	Platen gap motor pinion	G26
18	6-3	Carriage guide shaft gear	G26
19	6-3	Ribbon feed gears	G26
20	6-3	Tractor select cam	G26
21	6-4	Platen gap adjust middle gear	G26

NOTE: Refer to Figures 6-2 through 6-4.



Table 6-3. Adhesive Application Points

Ref No.	Reference Figure No.	Lubrication Points	Lubricant
22	6-3	Carriage motor fixing screw (2 screws)	Neji Lock #2 (G)
23	6-3	Timing belt holder fixing screw	
24	6-3	Parallelism adjustment <i>lever</i> fixing screw (2 screws)	
25	6-4	Lower paper guide Assembly fixing screw (3 screws)	
26	6-4	Terminal board fixing screw (2 screws)	
27	6-4	Platen gap motor fixing screw (2 screws)	
28	6-4	Platen gap motor fixing screw (2 screws)	
29	6-4	Pull tractor sensor fixing screw (Screw body side)	
30	6-4	External fan unit fixing screw (3 screws)	

NOTE: Refer to Figures 6-3 and 6-4.

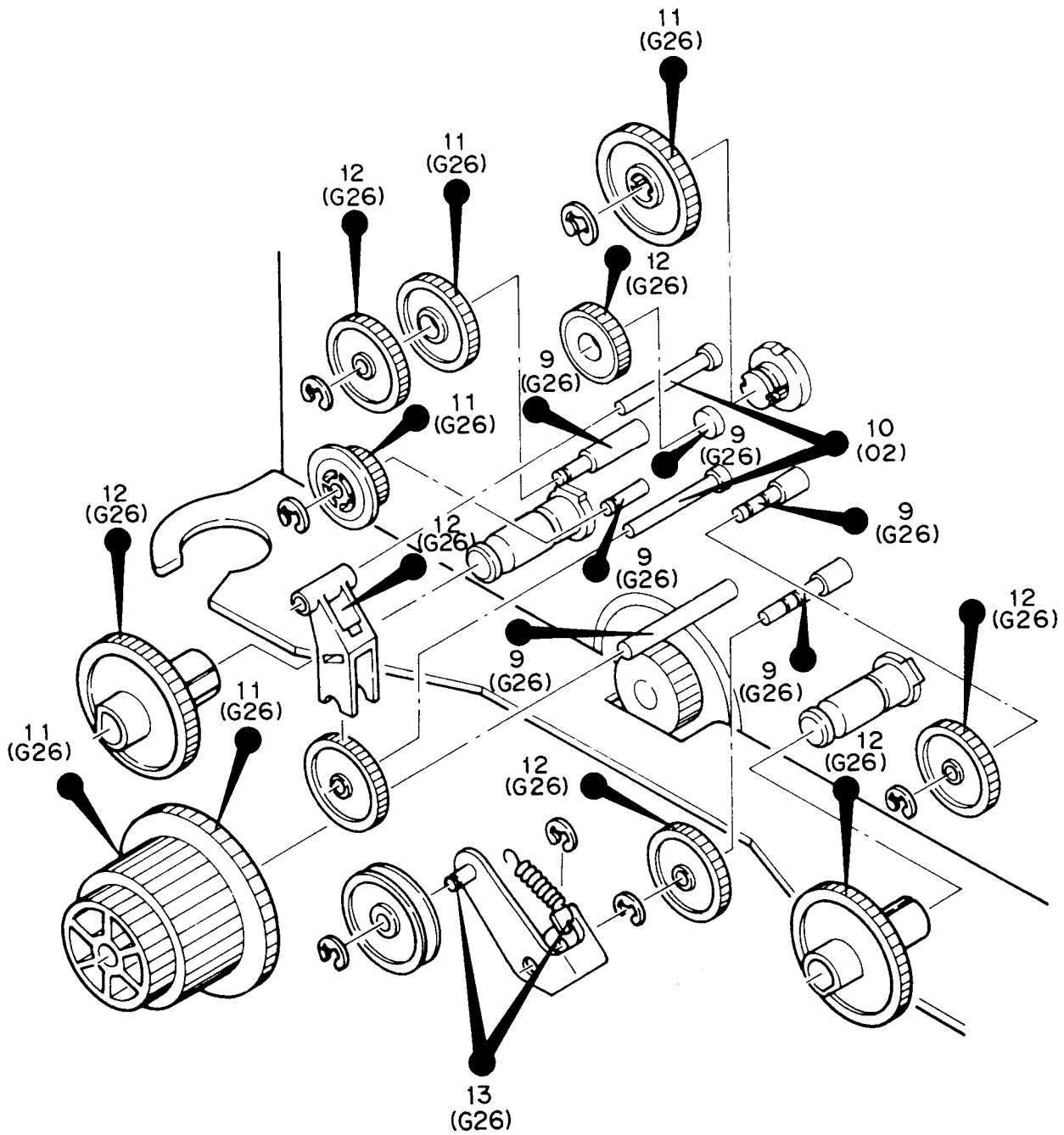

Figure 6-2. DFX-8000 Lubrication and Adhesive Diagram 1

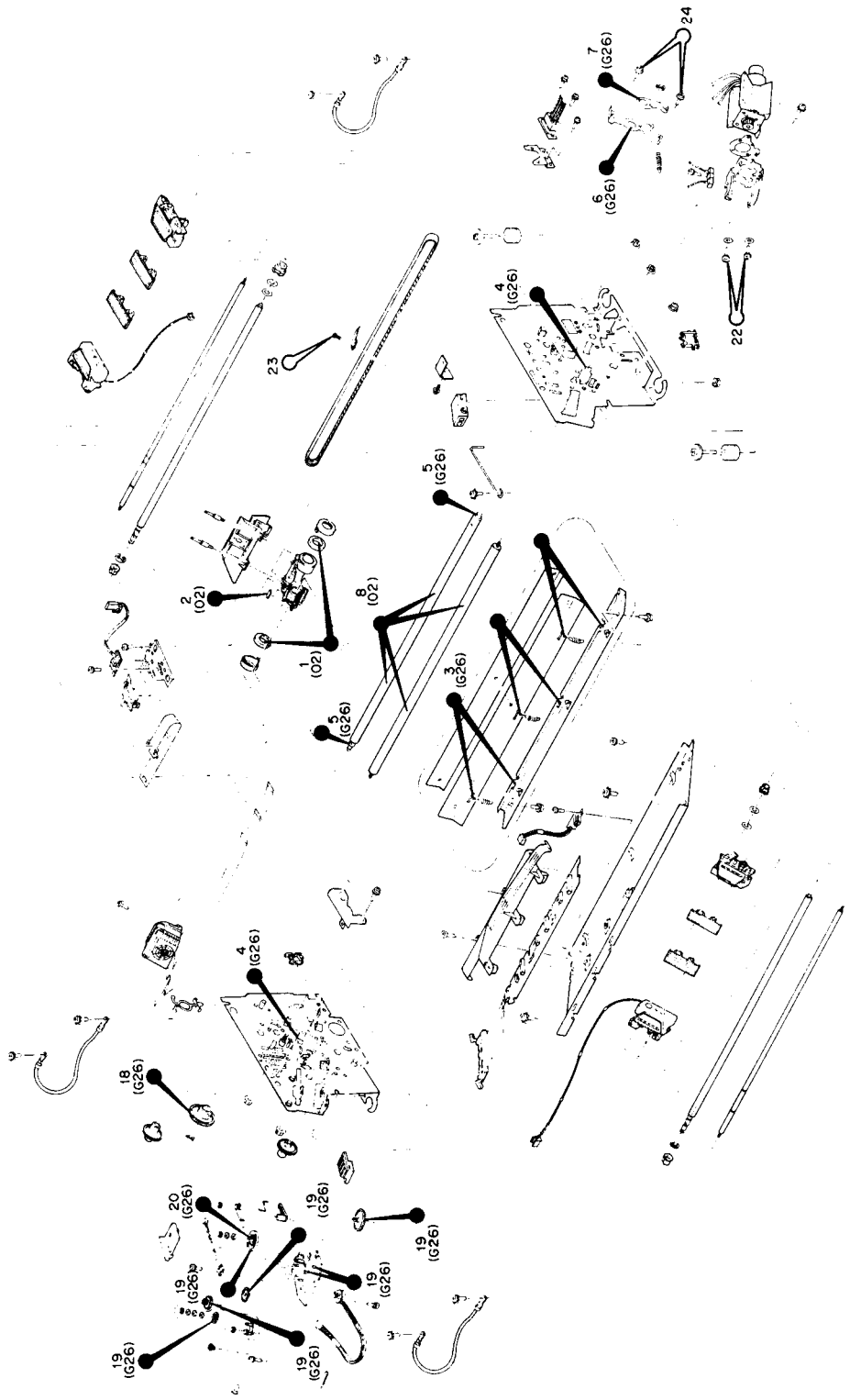

Figure 6-3. DFX-8000 Lubrication and Adhesive Diagram 2

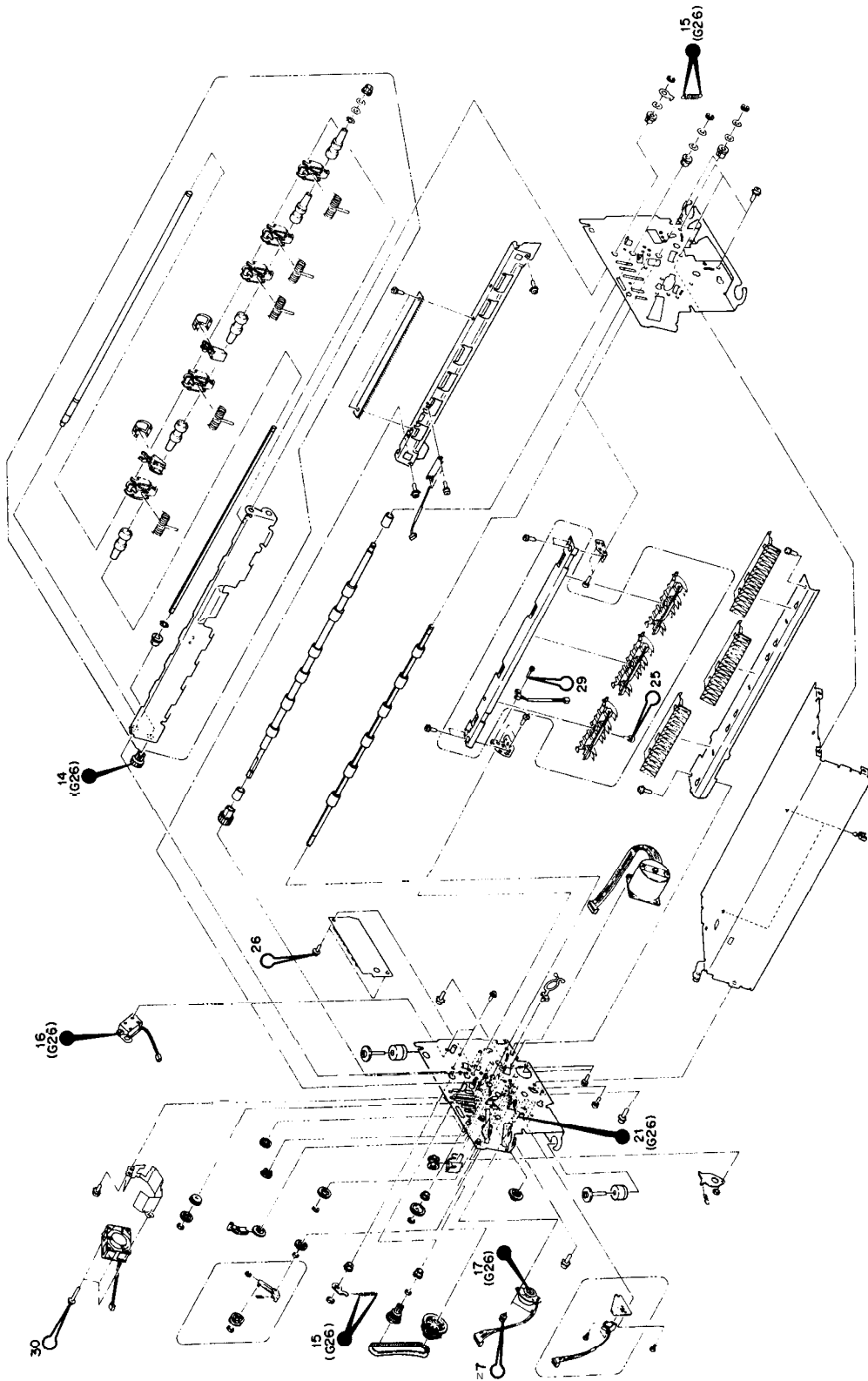

Figure 6-4. DFX-8000 Lubrication and Adhesive Diagram 3

# APPENDIX

A.1 COMPONENT CONNECTIONS ..... A-1  
 A.2 CIRCUIT DIAGRAMS AND SCHEMATICS ..... A-14

## LIST OF FIGURES

Figure A-1. Component Connections ..... A-1  
 Figure A-2. Terminal Board Connector Assignment Diagram ..... A-1 O  
 Figure A-3. Head Board Connector Assignment Diagram ..... A-1 2  
 Figure A-4. Board Component Layout ..... A-1 4  
 Figure A-5. Board Component Layout ..... A-1 5  
 Figure A-6. Board Component Layout ..... A-1 6  
 Figure A-7. Front Board Component Layout ..... A-1 7  
 Figure A-8. Control Panel Board Circuit Diagram ..... A-1 8  
 Figure A-9. Board Circuit Diagram (With Note) .....  
 Figure A-10. Board Circuit Diagram ..... A-20  
 Figure A-11. PI Board Circuit Diagram (With Note) ..... A-21  
 Figure A-12. Board Circuit Diagram ..... A-22  
 Figure A-13. Board Circuit Diagram (With Note) ..... A-23  
 Figure A-14. Carrier Board Circuit Diagram ..... A-24  
 Figure A-15. Carrier Board Circuit Diagram (With Note) ..... A-25  
 Figure A-16. Board Circuit Diagram ..... A-26  
 Figure A-17. Exploded Diagram ..... A-27  
 Figure A-18. Exploded Diagram -1 ..... A-28  
 Figure A-19. Exploded Diagram -2 ..... A-29  
 Figure A-20. External Dimension Diagram ..... A-30

## LIST OF TABLES

Table A-1. Connector Assignments ..... A-2  
 Table A-2. Pin Assignments ..... A-3  
 Table A-3. Pin Assignments ..... A-3  
 Table A-4. Pin Assignments ..... A-4  
 Table A-5. Pin Assignments ..... A-5  
 Table A-6. Pin Assignments ..... A-6

Table A-7. C030MAINC�8 Pin Assignments ..... A-6

Table A-8. C030MAINC�9 Pin Assignments ..... A-7

Table A-9. C030MAINC�10 Pin Assignments ..... A-7

Table A-1 0. C030DRVC�1 Pin Assignments ..... A-7

Table A-1 1. C030DRVC�2 Pin Assignments ..... A-7

Table A-1 2. C030DRVC�5 Pin Assignments ..... A-8

Table A-1 3. C030DRVC�6 Pin Assignments ..... A-9

Table A-1 4. C030DRVC�7 Pin Assignments ..... A-9

Table A-1 5. BOPS/BOPSEC�1 Pin Assignments ..... A-9

Table A-1 6. BOPS/BOPSEC�5 Pin Assignments ..... A-9

Table A-1 7. Terminal Board Connector Pin Assignments ..... A-1 1

Table A-1 8. Head Board Connector Pin Assignments ..... A-1 3

## A.1 COMPONENT CONNECTIONS

This section describes the component connection and detailed pin assignments of each connectors of units.

Figure A-1 shows the component connections of the DFX-8000, and Table A-1 lists the connector assignments and its reference tables.

Table A-2 through A-16 lists connector pin assignments.

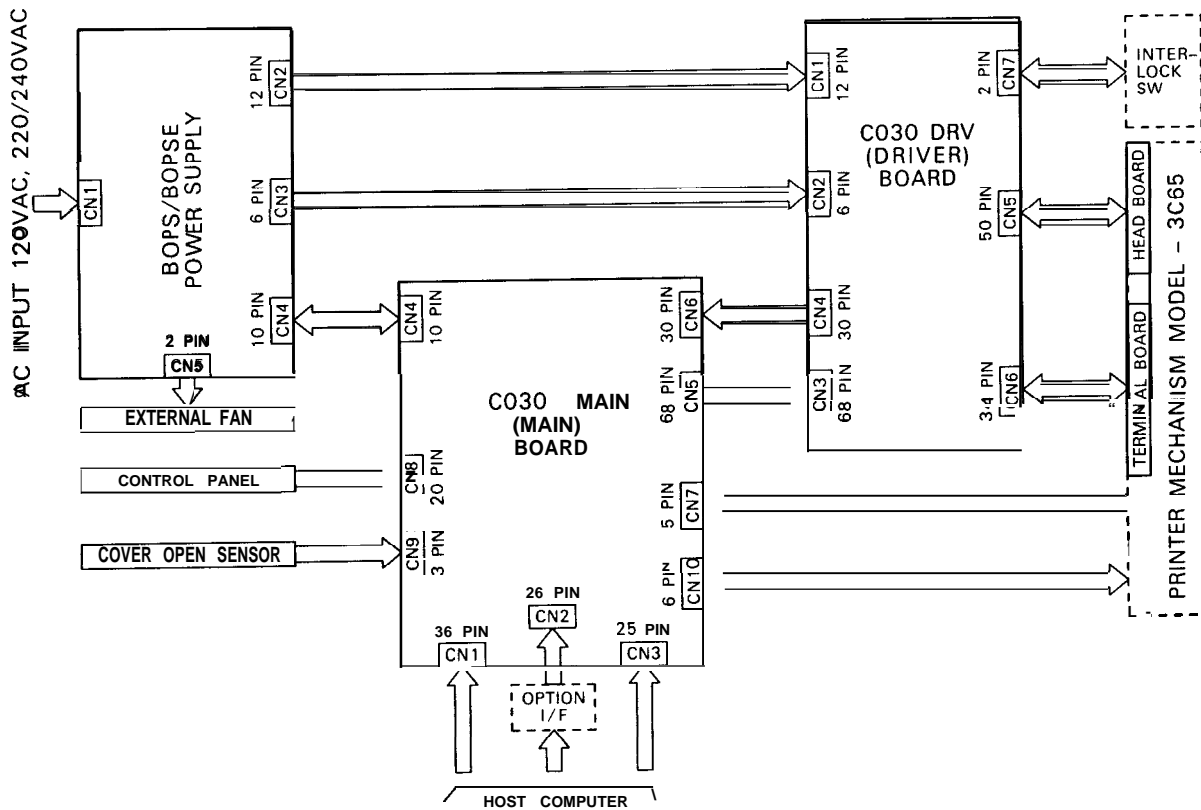

Figure A-1. Component Connections

Table A-1. Connector Assignments

Component Name	Connector Number	Pin Numbers	Description	Ref. Table
C030MAIN	CN1	36	Parallel Interface (Host computer)	1-6
	CN2	26	Optional interface control	A-2
	CN3	25	Serial interface (Host computer)	1-9
	CN4	10	Power supply input (+5VDC, 12VAC) Power supply control signal output/monitor signal input	A-3
	CN5	68	Printer mechanism control signal output	A-4
	CN6	30	Printer mechanism sensor signal input Driver circuit monitor signal input	A-5
	CN7	5	Carriage motor feed back signal input	A-6
	CN8	20	Control panel signal input/output	A-7
	CN9	3	Cover open sensor signal input	A-8
	CN 10	6	Option cutter unit control signal output/sensor signal input	A-9
C030DRV	CN 1	12	Power supply input (+35VDC)	A-1 0
	CN2	6	Power supply input (+35VDC)	A-1 1
	CN3	68	Printer mechanism control signal input	A-4
	CN4	30	Printer mechanism sensor signal output Driver circuit monitor signal output	A-5
	CN5	50	Printer mechanism sensor signal input Printhead drive signal output	A-1 2
	CN6	34	Printer mechanism sensor signal input Printer mechanism drive signal output	A-1 3
	CN7	2	Inter-lock switch connect	A-1 4
BOPS/ BOPSE	CN 1	3	AC input	A-1 5
	CN2	12	DC output (+35VDC)	A-1 0
	CN3	6	DC output (+ 35VDC)	A-1 1
	CN4	10	DC output (+5VDC, 12VAC) Power supply control signal input/monitor signal output	A-3
	CN5	2	Fan drive DC output (+35VDC)	A-1 6



Table A-2. C030MAINCN2 Pin Assignments

Pin No.	DIR	Name	Description
1	out	ERROR	Error signal
2	out	PE	Paper End signal
3	In	D7	Data input 7
4	out	BUSY	BUSY pulse
5	In	D6	Data input 6
6	out	ACK	ACKNOWLEDGE pulse
7	In	D5	Data input 5
8	In	INIT	Initialize signal
9	In	D4	Data input 4
10	In	STRB	STROBE pulse
11	In	D8	Data input 8
12	—	GND	Ground
13	out	RESET	Reset signal
14	—	- 1 2	- 12 VDC
15	In	D3	Data input 3
16	—	+ 5	+ 5 VDC
17	In	0 2	Data input 2
18	—	+ 2 4	+ 24 VDC
19	In	D1	Data input 1
20	—	+ 1 2	+ 12 VDC
21	In	P/s	Parallel/Serial signal
22	—	NC	Not connected
23	In	SELIN	Select in signal
24	—	GND	Ground
25	out	TXD	Transmission data
26	—	GND	Ground

Table A-3. C030MAINCN4 Pin Assignments

Pin No.	DIR	Name	Description
1 2	—	+ 5V	+5 VDC
3 4	—	GL	Logic ground
5	—	+ 12V	+ 12 VDC
6	—	- 12V	- 12 VDC
7	out	PH	Not connect
8	out	CL	Limit signal
9	out	PD	Power down signal
10	out	s o	Switch off signal

NOTE: The pin assignments in above table are corresponded with the pins of connector CN4 on the power supply board. ("In" and "Out" in a "DIR" changes to opposite direction.)

Table A-4. C030MAIN CN5 Pin Assignments

Pin No.	DIR	Name	Description
1	out	RFA	Ribbon motor A phase
2	out	RFB	Ribbon motor B phase
3	out	RFC	Ribbon motor C phase
4	out	RFD	Ribbon motor D phase
5	out	RFH/R	Ribbon motor common voltage (Hold/Run)
6	out	PFA	Paper feed motor A phase
7	out	PFB	Paper feed motor B phase
8	out	PFC	Paper feed motor C phase
9	out	PFD	Paper feed motor D phase
10	out	PFH/R	Paper feed motor drive current switch signal
11	out	PGA	Platen gap motor A phase
12	out	PGB	Platen gap motor B phase
13	out	PGC	Platen gap motor C phase
14	out	PGD	Platen gap motor D phase
15	out	PGH/R	Platen gap motor common voltage (Hold/Run)
16	out	CRA	Carriage motor driver signal A
17	out	CRB	Carriage motor driver signal B
18	out	CRC	Carriage motor driver signal C
19	out	CRD	Carriage motor driver signal D
20	out	CR1	CR motor drive current switch signal 1
21	out	CR2	CR motor drive current switch signal 2
22	out	CR3	CR motor drive current switch signal 3
23	out	HL1P	Printhead left line PNP drive signal # 1
24	out	HL2P	Printhead left line PNP drive signal #2
25	out	HL3P	Printhead left line PNP drive signal #3
26	out	HL4P	Printhead left line PNP drive signal #4
27	out	HL5P	Printhead left line PNP drive signal #5
28	out	HL6P	Printhead left line PNP drive signal #6
29	out	HL7P	Printhead left line PNP drive signal #7
30	out	HL8P	Printhead left line PNP drive signal #8
31	out	HL9P	Printhead left line PNP drive signal #9
32	out	HR1 P	Printhead right line PNP drive signal # 1
33	out	HR2P	Printhead right line PNP drive signal #2
34	out	HR3P	Printhead right line PNP drive signal #3
35	out	HR4P	Printhead right line PNP drive signal #4
36	out	HR5P	Printhead right line PNP drive signal #5
37	out	HR6P	Printhead right line PNP drive signal #6
38	out	HR7P	Printhead right line PNP drive signal #7
39	out	HR8P	Printhead right line PNP drive signal #8
40	out	HR9P	Printhead right line PNP drive signal #9
41	out	HL1N	Printhead left line NPN drive signal # 1
42	out	HL2N	Printhead left line NPN drive signal #2
43	out	HL3N	Printhead left line NPN drive signal #3
44	out	HL4N	Printhead left line NPN drive signal #4
45	out	HL5N	Printhead left line NPN drive signal #5
46	out	HL6N	Printhead left line NPN drive signal #6
47	out	HL7N	Printhead left line NPN drive signal #7
48	out	HL8N	Printhead left line NPN drive signal #8
49	out	HL9N	Printhead left line NPN drive signal #9
50	out	HR 1 N	Printhead right line NPN drive signal # 1
51	out	HR2N	Printhead right line NPN drive signal #2
52	out	HR3N	Printhead right line NPN drive signal #3
53	out	HR4N	Printhead right line NPN drive signal #4
54	out	HR5N	Printhead right line NPN drive signal #5
55	out	HR6N	Printhead right line NPN drive signal #6

Table A-4. C030MAINCN5 Pin Assignments (Cent'd)

Pin No.	DIR	Name	Description
56	out	HR7N	Printhead right line NPN drive signal #7
57	out	HR8N	Printhead right line NPN drive signal #8
58	out	HR9N	Printhead right line NPN drive signal #9
59	Out	HFANA	Head fan motor A phase
60	out	HFANB	Head fan motor B phase
61	out	PLGP	Plunger PNP drive signal
62	Out	PLGN	Plunger NPN drive signal
63	—	Vx	Vx voltage (+5 VDC)
64	—	+5	+5 VDC
65			
66	—	GND	Ground
68			

NOTE: The pin assignments in above table are corresponded with the pins of connector CN3 on the driver board. ("In" and "Out" in a "DIR" changes to opposite direction.)

Table A-5. C030MAINCN6 Pin Assignments

Pin No.	DIR	Name	Description
1	In	CRHP	Carriage home position signal
2	—	+5	+5 VDC
3	—	GND	Ground
4	In	HTMP	Printhead temperature monitor line
5	—	GND	Ground
6	In	PWIDTH	Paper width sensor signal
7	—	+5	+5 VDC
8	—	GND	Ground
9	In	FTMP	Head cooling fan temperature monitor line
10	—	GND	Ground
11	In	TRCTSEL	Tractor select sensor signal
12	—	GND	Ground
13	In	GAP A	Platen gap sensor A phase
14		GAP B	Platen gap sensor B phase
15	In	TPE	Upper(Top) paper end sensor signal
16	In	FPE	Front paper end sensor signal
17	In	RPE	Rear paper end sensor signal
18	—	+5	+5 VDC
19	—	GND	Ground
20			
21	In	PTRCT	Pull tractor sensor signal
22	—	GND	Ground
23	In	HNERR	Head driver (NPN) short/open signal
24		HPERR	Head driver (PNP) short/open signal

Table A-5. C030MAINCN6 Pin Assignments (Cent'd)

Pin No.	DIR	Name	Description
25 26	—	+ 5	+5 VDC
27	In	DV35	+ 35 VDC(VP3) monitor line
28 30	—	GND	Ground

NOTE: The pin assignments in above table are corresponded with the pins of connector CN4 on the driver board. ("In" and "Out" in a "DIR" changes to opposite direction.)

Table A-6. C030MAINCN7 Pin Assignments

Pin No.	DIR	Name	Description
1	—	+ 5	+ 5 VDC
2	1 - 1	GND	Ground
3	In	ENCA	Carriage encoder A phase output
4	In	ENC B	Carriage encoder B phase output
5	In	MTRTMP	Carriage motor temperature monitor line

Table A-7. C030MAINCN8 Pin Assignments

Pin No.	DIR	Name	Description
1	out	ON LINE LP	ON LINE LED drive signal
2	out	BUZZ	Buzzer drive signal
3	out	PE LP	Paper end LED drive signal
4	out	READY LP	Ready LED drive signal
5	out	FRONT GLP	Front tractor select LED drive signal
6	out	FRONT RLP	Front tractor paper end LED drive signal
7	out	REAR GLP	Rear tractor select LED drive signal
8	out	REAR RLP	Rear tractor paper end LED drive signal
9	out	TOF LP	TOF LED drive signal
10	out	TEAR OFF LP	Tear-off LED drive signal
11	In	FF SW	Form feed switch
12	In	ON LINE SW	ON LINE switch
13	In	TEAR OFF SW	Tear-off switch
14	In	LF SW	Line feed switch
15	In	TOF SW	Top of form switch
16	In	PAPER SEL SW	Paper select switch
17	In	MFF SW	Micro feed (front) switch
18	In	MFB SW	Micro feed (back) switch
19	—	GND	Ground
20	—	+ 5	+ 5 VDC

**Table A-8. C030MAINCN9 Pin Assignments**

Pin No.	DIR	Name	Description
1	—	+ 5	+5 VDC
2	In	COVER SW	Cover open sensor signal
3	—	GND	Ground

**Table A-9. C030MAINCN1 O Pin Assignments**

Pin No.	DIR	Name	Description
1	Out	CUTON	Cutter ON signal
2	out	CUTDIR	Cutter direction signal
3	In	CUTTER	Cutter install signal
4	In	CUTHP	Cutter home position sensor signal
5	—	+ 5	+5 VDC
6	—	GND	Ground

**Table A-1 O. C030DRVCN1 Pin Assignments**

Pin No.	DIR	Name	Description
1 2 3	—	VP1	+35 VDC
4 5 6	—	GP1	Ground for VP 1
7 8 9	—	VP2	+35 VDC
10 11 12	—	GP2	Ground for VP2

NOTE: The pin assignments in above table are corresponded with the pins of connector CN2 on the power supply board.

**Table A-1 1. C030DRVCN2 Pin Assignments**

Pin No.	DIR	Name	Description
1 2 3	—	VP3	+35 VDC
4 5 6	—	GP3	Ground for VP3

NOTE: The pin assignments in above table are corresponded with the pins of connector CN3 on the power supply board.

Table A-1 2. C030DRV CN5 Pin Assignments

Pin No.	DIR	Name	Description
1	out	# 6	Printhead drive signal #6 (HR3P)
2	out	# 4	Printhead drive signal #4 (HR2P)
3	Out	# 18 GND	Printhead ground signal #18 (HR9N)
4	out	# 4 GND	Printhead ground signal #4 (HR2N)
5	out	# 14	Printhead drive signal #14 (HR7P)
6	out	# 14GND	Printhead ground signal #14 (HR7N)
7	out	# 18	Printhead drive signal #18 (HR9P)
8	out	# 6 GND	Printhead ground signal #6 (HR3N)
9	out	# 15	Printhead drive signal #15 (HL8P)
10	out	# 5 GND	Printhead ground signal #5 (HL3N)
11	out	# 13	Printhead drive signal #13 (HL7P)
12	out	# 3 GND	Printhead ground signal #3 (HL2N)
13	out	# 15GND	Printhead ground signal #15 (HL8N)
14	out	# 13 GND	Printhead ground signal #13 (HL7N)
15	out	# 5	Printhead drive signal #5 (HL3P)
16	out	# 3	Printhead drive signal #3 (HL2P)
17	out	# 8	Printhead drive signal #8 (HR4P)
18	out	# 16 GND	Printhead ground signal #16 (HR8N)
19	out	# 10	Printhead drive signal #10 (HR5P)
20	Out	# 8 GND	Printhead ground signal #8 (HR4N)
21	out	# 12	Printhead drive signal #12 (HR6P)
22	out	# 10GND	Printhead ground signal #10 (HR5N)
23	out	# 16	Printhead drive signal #16 (HR8P)
24	Out	# 12GND	Printhead ground signal #12 (HR6N)
25	out	# 17GND	Printhead ground signal #17 (HL9N)
26	out	# 9 GND	Printhead ground signal #9 (HL5N)
27	out	# 17	Printhead drive signal #17 (HL9P)
28	out	# 11 GND	Printhead ground signal #11 (HL6N)
29	out	# 11	Printhead drive signal #11 (HL6P)
30	out	# 7 GND	Printhead ground signal #7 (HL4N)
31	out	# 9	Printhead drive signal #9 (HL5P)
32	out	# 7	Printhead drive signal #7 (HL4P)
33	out	# 2	Printhead drive signal #2 (HR1 P)
34	out	# 1	Printhead drive signal #1 (HL1 P)
35	Out	HFANB	Printhead cooling fan motor B phase
36	out	#1 GND	Printhead ground signal #1 (HL1 N)
37	out	FANCOM	Printhead cooling fan motor common voltage
38	out	# 2 GND	Printhead ground signal #2 (HR 1 N)
39	out	HFANA	Printhead cooling fan motor A phase
40	In	HTMP	Printhead temperature monitor line
41	—	+ 5	+ 5 VDC
42	—	GND	Ground
43	In	CRHP	Carriage home position signal
44	In	FTMP	Head cooling fan temperature monitor line
45	—	GND	Ground
46			
47	In	PWIDTH	Paper width sensor signal
48	—	GND	Ground
49	—	+ 5	+ 5 VDC
50	—	—	Not connected

NOTE: The pin assignments in above table are corresponded with the pins of connectors on the head board shown in Figure A-3 and Table A-18.

Table A-1 3. C030DRVCN6 Pin Assignments

Pin No.	DIR	Name	Description
1	In	TRCTSEL	Tractor select sensor signal
2	—	GND	Ground
3	out	RFCOM	Ribbon motor common voltage (Hold/Run)
4	—	GP3	Ground for VP3
5	out	RFD	Ribbon motor D phase
6	out	RFC	Ribbon motor C phase
7	out	RFB	Ribbon motor B phase
8	out	RFA	Ribbon motor A phase
9,10	out	PGCOM	Platen gap motor common voltage (Hold/Run)
11	out	PGD	Platen gap motor D phase
12	out	PGC	Platen gap motor C phase
13	out	PGB	Platen gap motor B phase
14	out	PGA	Platen gap motor A phase
15	In	GAP A	Platen gap sensor A phase
16	In	GAP B	Platen gap sensor B phase
17	In	RPE	Rear paper end sensor signal
18	In	TPE	Upper (Top) paper end sensor signal
19	—	+ 5	+5. VDC
20	In	FPE	Front paper end sensor signal
21	In	PTRCT	Pull tractor sensor signal
22	out	PFA	Paper feed motor A phase
23	—	GND	Ground
24	out	PFB	Paper feed motor B phase
25	out	PLGP	Plunger PNP drive signal
26	out	PFC	Paper feed motor C phase
27	out	PLGN	Plunger NPN drive signal
28	out	PFD	Paper feed motor D phase
29,30	out	CRA	Carriage motor common line A
31	out	CRB	Carriage motor common line B
32	out	PFCOM	Paper feed motor common line
33	out	CRB	Carriage motor common line B
34	out	PFCOM	Paper feed motor common line

NOTE: The pin assignments in above table are corresponded with the pins of connectors on the terminal board shown in Figure A-2 and Table A-17.

Table A-14. C030DRVCN7 Pin Assignments

Pin No.	DIR	Name	Description
1,2	—	VP3	+35VDC (Carriage motor common) inter-lock switch

Table A-1 5. BOPS/BOPSECN1 Pin Assignments

Pin No.	DIR	Name	Description
1	In	L	AC input (L)
2	—	—	Not connected
3	In	N	AC input (N)

Table A-1 6. BOPS/BOPSECN5 Pin Assignments

Pin No.	DIR	Name	Description
1,2	out	FAN	+ 35VDC (VP3) power supply unit cooling fan drive voltage

REV.-A

The terminal board is located at the left side frame of printer mechanism.  
The terminal board distribute the drive signals of mechanism from the driver board, and send back sensor signals to the main board through the driver board.  
Figure A-2 shows the connector assignments of the terminal board, and Table A-17 lists the pin assignments of each connector.

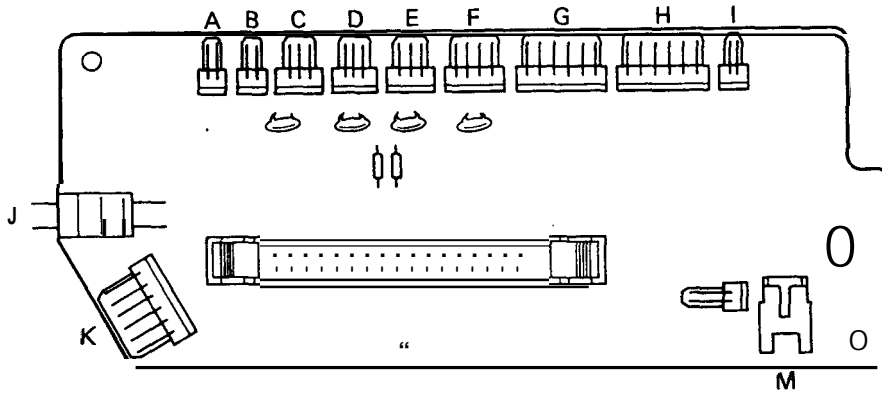

Figure A-2. Terminal Board Connector Assignment Diagram



Table A-1 7. Terminal Board Connector Pin Assignments

Connector Location (Fig. A-2)	Pin No.	DIR	Name	Description
A	1	out	PLGN	Plunger NPN drive signal
	2	out	PLGP	Plunger PNP drive signal
B	1	—	GND	Ground
	2	In	TRCT	Pull tractor sensor signal
c	1	—	+ 5	+5 VDC
	2	In	FPE	Front paper end sensor signal
	3	—	GND	Ground
D	1	—	+ 5	+ 5 VDC
	2	In	RPE	Rear paper end sensor signal
	3	—	GND	Ground
E	1	—	+ 5	+5 VDC
	2	In	TPE	Upper (ToP) paper end sensor signal
	3	—	GND	Ground
F	1	—	+ 5	+5 VDC
	2	In	GAP A	Platen gap sensor A phase
	3		GAP B	Platen gap sensor B phase
	4	—	GND	Ground
G	1	out	PGB	Platen gap motor B phase
	2	out	PGA	Platen gap motor A phase
	3	out	PGD	Platen gap motor D phase
	4	out	PGC	Platen gap motor C phase
	5	out	PGCOM	Platen gap motor common voltage
	6			
H	1	out	RFB	Ribbon motor B phase
	2	out	RFA	Ribbon motor A phase
	3	out	RFD	Ribbon motor D phase
	4	out	RFC	Ribbon motor C phase
	5	out	RFCOM	Ribbon motor common voltage
	6	out	RFCOM	Ribbon motor common voltage
I	1	In	TRCTSEL	Tractor select sensor signal
	2	—	GND	Ground
J	1	out	CRA	Carriage motor common line A
	2	out	CRB	Carriage motor common line B
K	1	out	PFCOM	Paper feed motor common line
	2		PFCOM	Paper feed motor common line
	3	out	PFD	Paper feed motor D phase
	4	out	PFC	Paper feed motor C phase
	5	out	PFB	Paper feed motor B phase
	6	out	PFA	Paper feed motor A phase
L	1	out	RFCOM	Ribbon motor common voltage
	2	—	GP3	Ground for VP3
M	1	—	GP3	Ground for VP3
	2	out	PFCOM	Paper feed motor common line

REV.-A

The head board is located on the right side of carriage base plate.

The head board distribute the drive signals of printhead from the driver board, and send back sensor signals to the main board through the driver board.

Figure A-3 shows the connector assignments of the head board, and Table A- 18 lists the pin assignments of each connector.

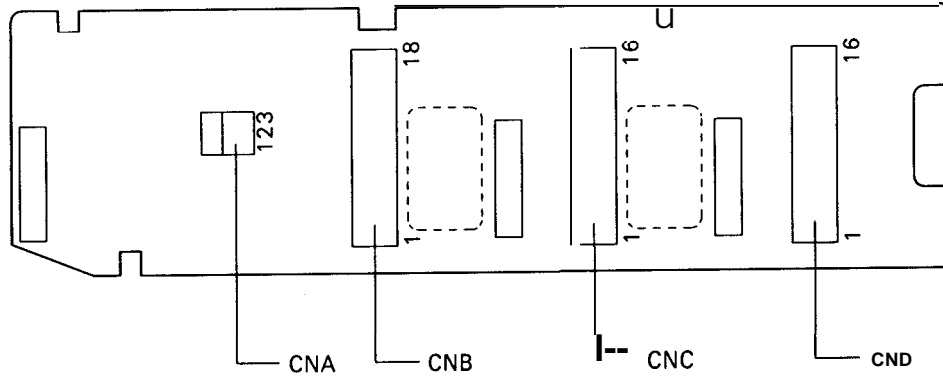

Figure A-3. Head Board Connector Assignment Diagram

Table A-1 8. Head Board Connector Pin Assignments

Connector Location (Fig. A-3)	Pin No.	DIR	Name	Description
A	1		+ 5	+ 5 VDC
	2	In	CRHP	Carriage home position signal
	3	—	GND	Ground
B	1	out	# 2	Printhead drive signal #2 (HR 1 P)
	2	out	# 1	Printhead drive signal #1 (HL1 P)
	3	out	HFANB	Printhead cooling fan motor B phase
	4	out	# 1 GND	Printhead ground signal #1 (HL1 N)
	5	out	FANCOM	Head fan motor common voltage
	6	out	# 2 GND	Printhead ground signal #2 (HR 1 N)
	7	out	HFANA	Printhead cooling fan motor A phase
	8	In	HTMP	Printhead temperature monitor line
	9	—	—	* CNA 1 oin
	10	—	GND	Ground
	11	—	—	* CNA 2 pin
	12	In	FTMP	Head fan temperature monitor line
	13	—	—	• CNA 3 pin
	14	—	GND	Ground
	15	In	PWIDTH	Paper width sensor signal
	16	—	GND	Ground
	17	—	+5	+5 VDC
	18	—	—	Not connected
c	1	Out	#8	Printhead drive signal #8 (HR4P)
	2	Out	#16GND	Printhead ground signal #16 (HR8N)
	3	Out	#10	Printhead drive signal #10 (HR5P)
	4	Out	#8 GND	Printhead ground signal #8 (HR4N)
	5	Out	#12	Printhead drive signal #12 (HR6P)
	6	Out	#10GND	Printhead ground signal #10 (HR5N)
	7	Out	#16	Printhead drive signal #16 (HR8P)
	8	Out	#12GND	Printhead ground signal #12 (HR6N)
	9	Out	#17GND	Printhead ground signal #17 (HL9N)
	10	Out	#9 GND	Printhead ground signal #9 (HL5N)
	11	Out	#17	Printhead drive signal #17 (HL9P)
	12	Out	#11GND	Printhead ground signal #11 (HL6N)
	13	Out	#11	Printhead drive signal #11 (HL6P)
	14	Out	#7 GND	Printhead ground signal #7 (HL4N)
	15	Out	#9	Printhead drive signal #9 (HL5P)
	16	Out	#7	Printhead drive signal #7 (HL4P)
D	1	Out	#6	Printhead drive signal #6 (HR3P)
	2	Out	#4	Printhead drive signal #4 (HR2P)
	3	Out	#18GND	Printhead ground signal #18 (HR9N)
	4	Out	#4 GND	Printhead ground signal #4 (HR2N)
	5	Out	#14	Printhead drive signal #14 (HR7P)
	6	Out	#14GND	Printhead ground signal #14 (HR7N)
	7	Out	#18	Printhead drive signal #18 (HR9P)
	8	Out	#6 GND	Printhead ground signal #6 (HR3N)
	9	Out	#15	Printhead drive signal #15 (HL8P)
	10	Out	#5 GND	Printhead ground signal #5 (HL3N)
	11	Out	#13	Printhead drive signal #13 (HL7P)
	12	Out	#3 GND	Printhead ground signal #3 (HL2N)
	13	Out	#15GND	Printhead ground signal #15 (HL8N)
	14	Out	#13GND	Printhead ground signal #13 (HL7N)
	15	Out	#5	Printhead drive signal #5 (HL3P)
	16	Out	#3	Printhead drive signal #3 (HL2P)

## A.2 CIRCUIT DIAGRAMS AND SCHEMATICS

- NOTES: 1. Figure that is with attached title of "With Note" means, it indicated block line and information correspond with CHAPTER 2 on the normal circuit diagram by red line.  
 2. Please refer to the parts price list about parts code and name.

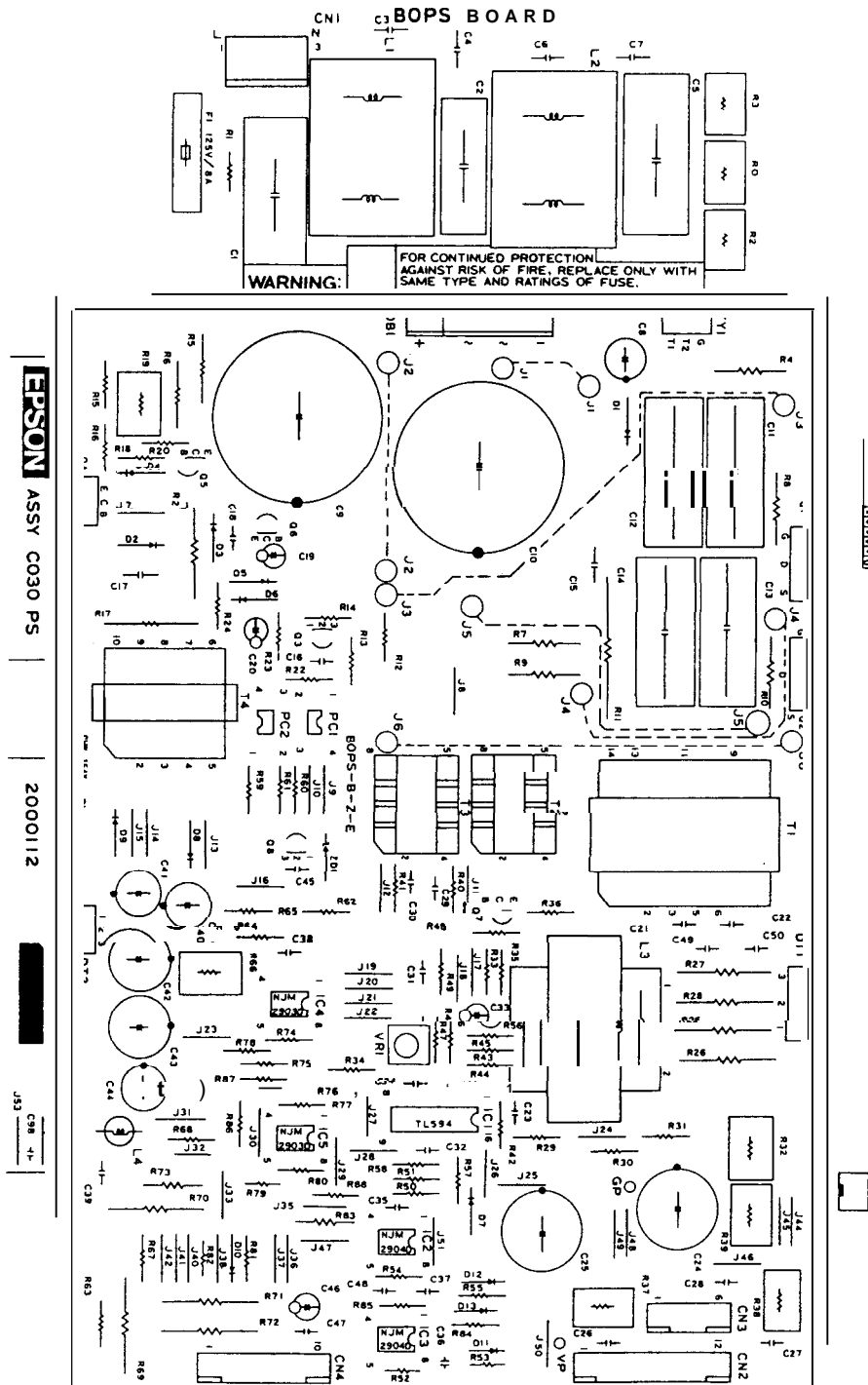

Figure A-4. BOPS Board Component Layout

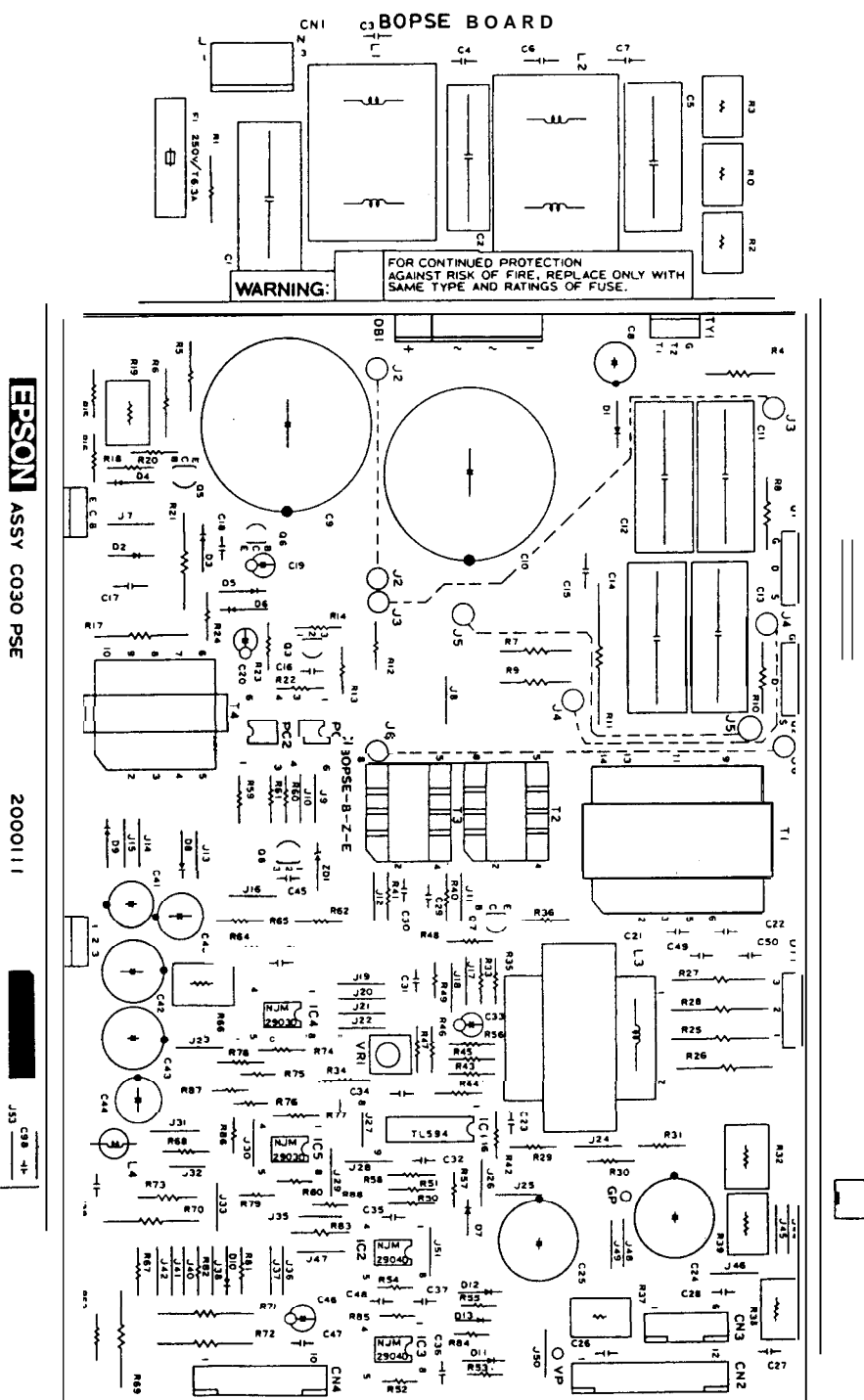

Figure A-5. BOPSE Board Component Layout

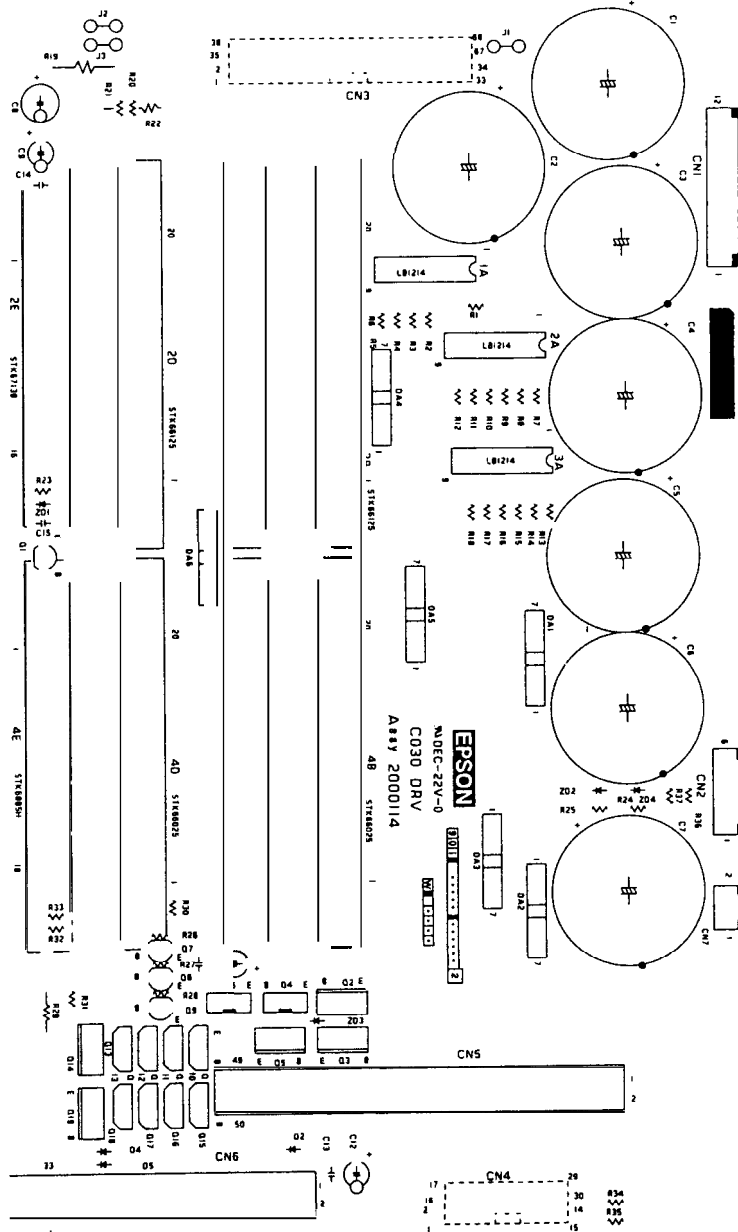

Figure A-6. C030DRV Board Component Layout

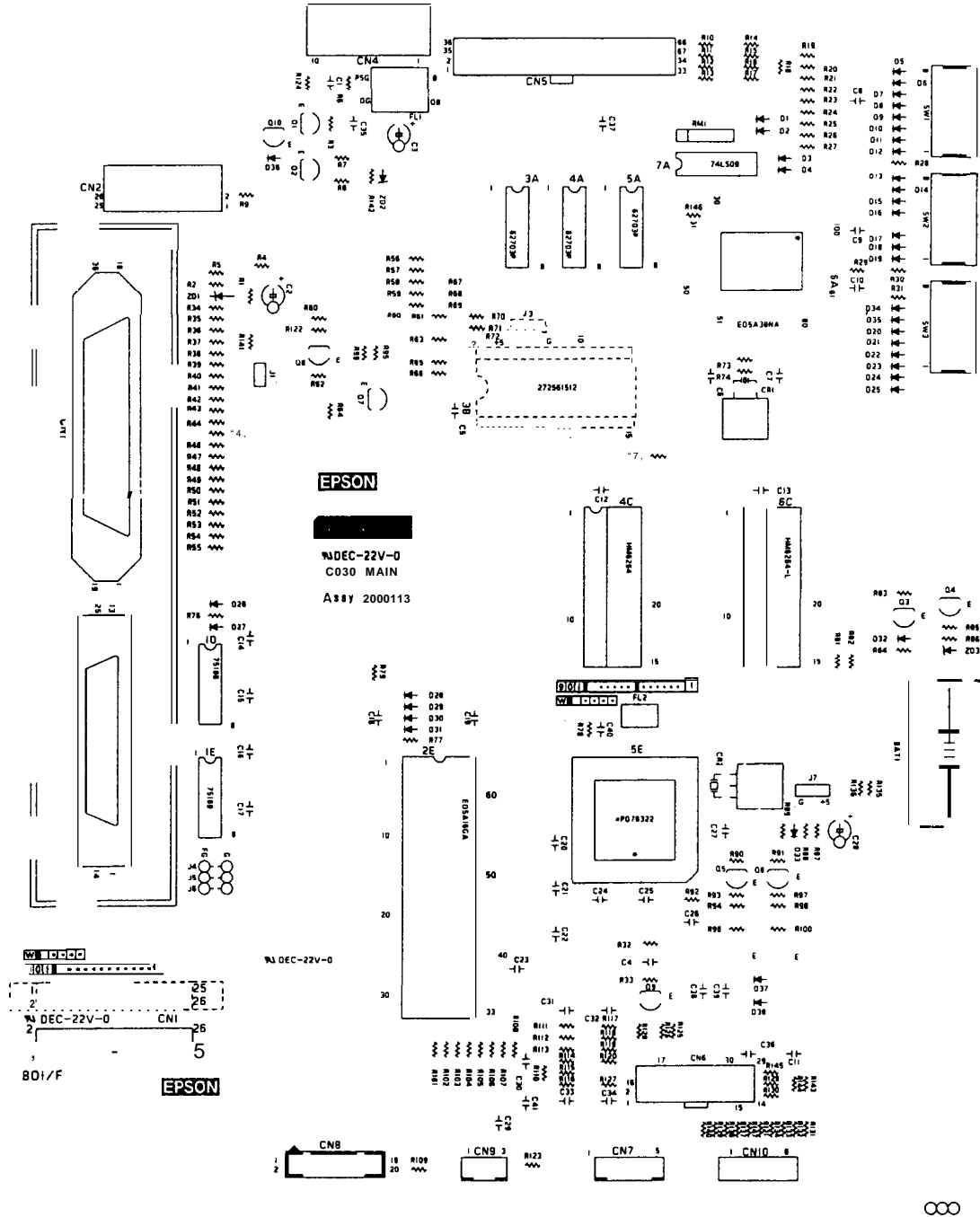

Figure A-7. C030MAIN Board Component Layout

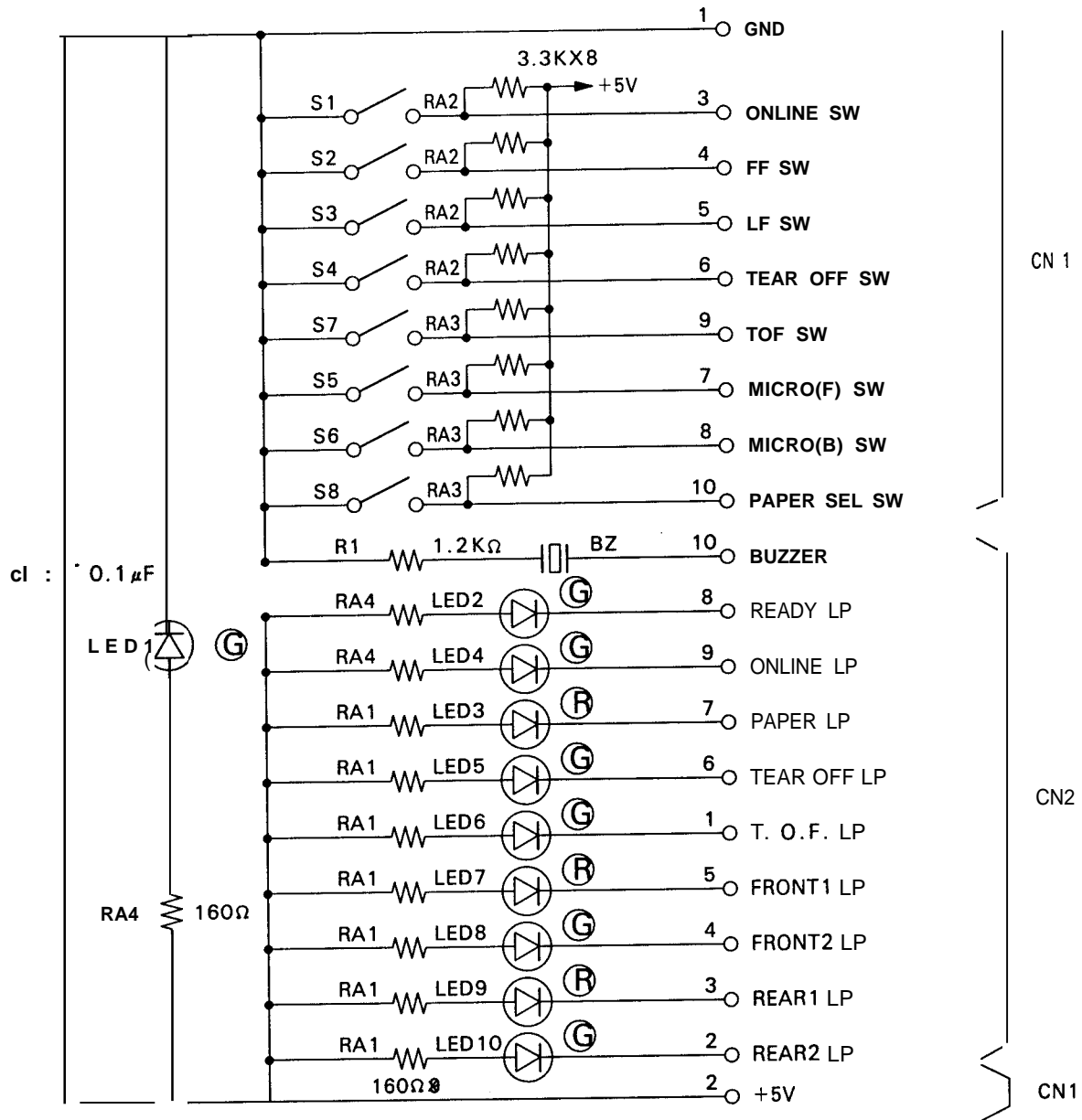

Figure A-8. Control Panel Board Circuit Diagram



**EPSON**